

The 545T Nite-Lite system is designed to manage the vehicle's headlights and parking lights. It will automatically energize the vehicle's headlights and parking lights whenever it becomes dark, or whenever the vehicle's windshield wipers are turned on. If used with a security system, the 545T will turn on the headlights and flash the parking lights on arming and disarming, if it is dark. The 545T has the ability to add daytime running lights to a vehicle and can also be activated and deactivated by one of the security system's auxiliary channels.

## WIRING DIAGRAM

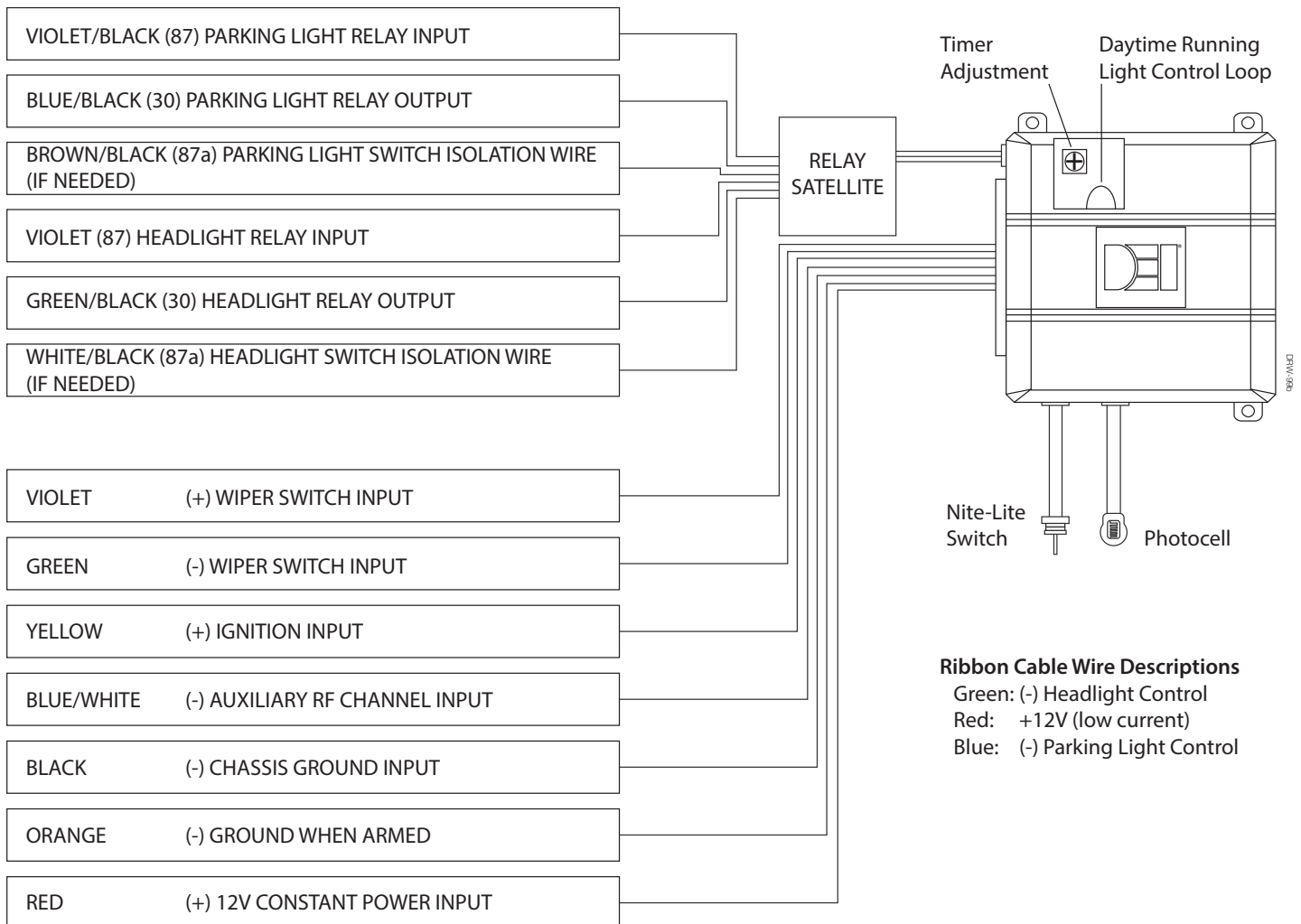

## WIRE CONNECTION GUIDE

### Main Harness

**RED (+)12V constant power input:** Connect to a fused source of constant 12V.

**ORANGE (-) ground-when-armed input:** Connect to the ground-when-armed output of the security system.

**BLACK (-) chassis ground input:** Connect this wire to a paint-free surface on the vehicle chassis.

**BLUE/WHITE (-) auxiliary RF channel input:** Connect this wire to an auxiliary channel output of the security system. The output must provide a validity or pulsed (-) output, a latched channel cannot be used.

**YELLOW (+) ignition input:** Connect to a switched ignition input.

**GREEN (-) wiper switch input:** If the vehicle uses a (-) ground switch to turn the wipers on, connect to the wire that reads (-) ground when the wipers are activated. NOTE: If this wire is used, **do not** connect the violet wire.

**VIOLET (+) wiper switch input:** If the vehicle uses a (+)12V switch to turn the wipers on, connect to the wire that reads (+)12V when the wipers are activated. NOTE: If this wire is used, **do not** connect the green wire.

### Relay Satellite Wires

**VIOLET/BLACK Light Relay Input:** Pin 87 (30A fused) of the parking light relay. This wire determines the output polarity of the Blue/Black Parking Light Output wire. If the parking light circuit in the vehicle requires +12V, connect this wire to +12V constant. If the parking light circuit in the vehicle requires a negative, connect this wire to ground.

**IMPORTANT!** This wire will handle the full current of the parking light circuit the entire time the Nite-Lite is activated. Be sure that it is connected to a source capable of handling a large current draw.

**BLUE/BLACK Parking Light Relay Output:** Pin 30 of the parking light relay. This wire connects to the parking light circuit in the vehicle.

**BROWN/BLACK Parking Light Isolation Wire\*:** Pin 87a of the parking light relay. This wire will be used in applications where the parking light circuit in the vehicle needs to be isolated, typically a Headlight Switch, Body Control Module or a Factory Relay.

**VIOLET Headlight Relay Input:** Pin 87 (30A fused) of the headlight relay. This wire determines the output polarity of the Green/Black Headlight Output wire. If the headlight circuit in the vehicle requires +12V, connect this wire to +12V constant. If the headlight circuit in the vehicle requires a negative connect this wire to a good ground source.

**IMPORTANT!** This wire will handle the full current of the headlight circuit in the vehicle the entire time the Nite-Lite is activated. Be sure that it is connected to a source capable of handling a large current draw. If the vehicle's headlight fuse is larger than 30 amps, the wire gauge and fuse size must be increased to accommodate the additional current draw. **The fuse on this wire must be at least the same size as the vehicles headlight fuse.**

**Green/Black Headlight Relay Output:** Pin 30 of the headlight relay. This wire connects to the headlight circuit in the vehicle.

**White/Black Headlight Isolation Wire\*:** Pin 87a of the headlight relay. This wire will be used in applications where the parking light circuit in the vehicle needs to be isolated, typically a Headlight Switch, Body Control Module or a Factory Relay.

**\*These wires are only used in special circumstances and are not be used in a basic positive or negative circuit.**

## PLUG-IN HARNESS

### Relay satellite, 3-pin white plug

**RED:** Supplies power to terminal 86 of the headlight and parking light relays

**BLUE:** (-) trigger to terminal 85 of the parking light relay

**GREEN:** (-) trigger to terminal 85 of the headlight relay

### Nite-Lite on/off switch, 2-pin blue plug

The Nite-Lite on/off switch completely disables the photocell. When the switch is turned on, the vehicle's parking lights and headlights will not be energized automatically when the ignition is turned on, nor will they come on when the vehicle's security system is armed or disarmed. However, the Nite-Lite will still respond to the wiper inputs and to the auxiliary channel input. Mount this switch where it can be easily accessed from the driver seat, but cannot be accidentally operated.

### Photocell, 2-pin red plug

The photocell senses whether it is dark or light. It should be mounted in a location where it is exposed to direct sunlight. For example, the top of the dash-pad at the center of the windshield would be an ideal location. Do not mount on the rear deck, as most vehicles have factory tint which can affect the photocell's sensitivity.

**NOTE:** Take care not to reverse the photocell and toggle switch when plugging them in. These plugs are not interchangeable. Plugging the toggle switch into the photocell port will cause damage to the module.

## IDENTIFYING THE LIGHTING SYSTEM

The first step in installing the 545T Nite-Lite is to determine the polarity of the vehicle's parking light and headlight circuits. In most vehicles, both the parking lights and the headlights will be either positive or negative. However, there are some vehicles that use (+)12V to activate one circuit and (-) ground to activate the other circuit. Many vehicles also combine the on/off switch and the high/low beam switch into one unit. In this case the high/low beam switch will not operate while the Nite-Lite is activated. **The customer should be informed of this.**

**NOTE:** All switch diagrams are drawn to illustrate low-beam operation only, even though many switch systems will allow both low and high beam operation.

### (+) Triggered parking lights and headlights

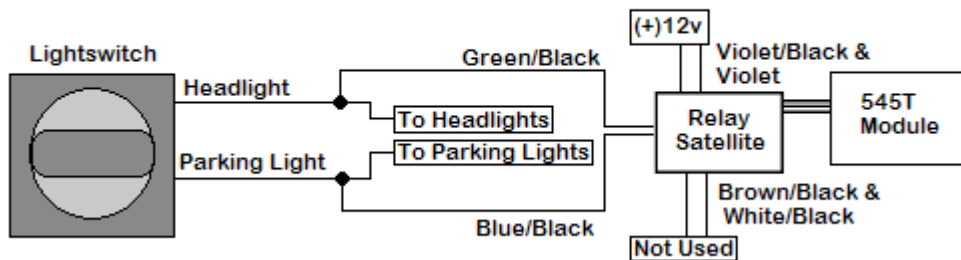

Fig. 1

### (-) Triggered parking lights and headlights

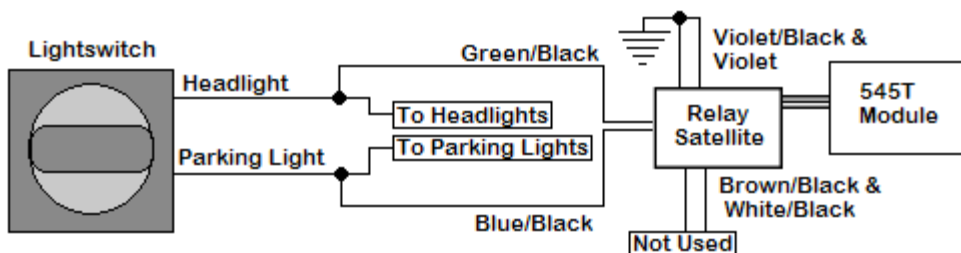

Fig. 2

**(+) Trigger for one circuit and (-) for the other circuit**

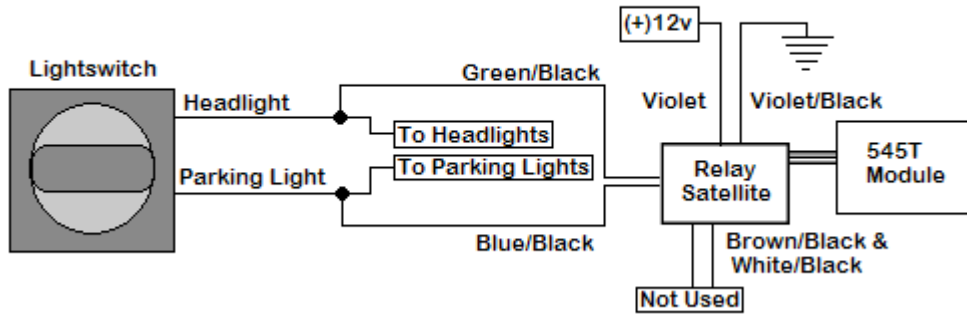

Fig. 3

**Switch isolation circuit for (+) or (-) triggered system**

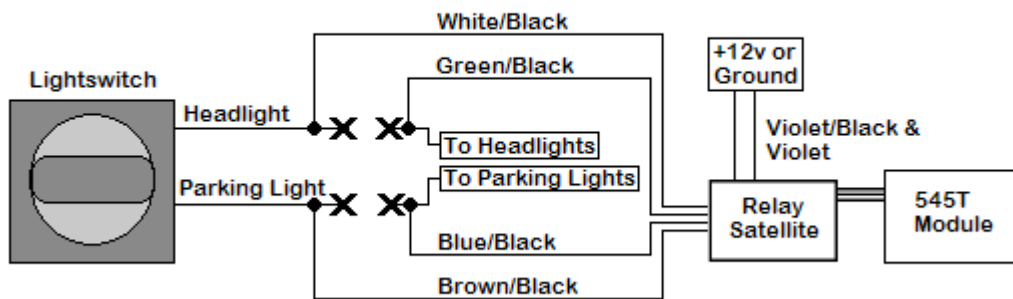
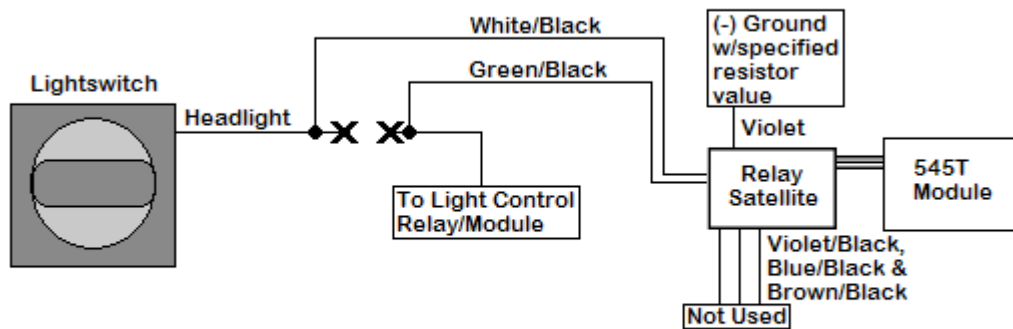

Fig. 4

**Multiplex circuit for (-) triggered systems w/switch isolation**



**NOTE:** With multiplex controlled circuits it is recommended to use the headlight resistance value. This will provide headlight and parking light illumination. Attempting to get the headlights and parking lights to function independently of each other is not recommended.

Fig. 5

**IMPORTANT!** Remember that the relay contacts and the wires connected to them will handle the full current of the headlight and parking light circuits throughout the operation of the system (if the lighting circuits are direct wired). In these cases, ensure that all (+)12V or (-) ground connections are capable of handling the current required.

## OPERATION MODES

### Standard Nite-Lite Mode

Whenever the Nite-Lite on/off switch is off and Safe-Lite Mode (if installed) is off, the 545T is in standard Nite-Lite operating mode. In this mode the system will continuously monitor the photocell. As soon as the photocell does not sense enough light it will turn the headlights and parking lights on with the ignition on. It will also turn on the headlights and flash the parking lights for a selectable time period every time the security system is armed or disarmed, or if the (-) auxiliary channel input is triggered. If the Nite-Lite is turned on by the security system, that one operation can also be canceled by triggering the (-) auxiliary channel input.

### Safe-Lite Mode (optional)

To install the Safe-Lite option, simply wire a toggle switch (not included) in series with either one of the photocell wires (cut one lead to the photocell, and connect each side to one side of the toggle switch). If the switch is **on**, the Nite-Lite will operate normally. If the toggle switch is **off**, the system is in Safe-Lite Mode and the vehicle's headlights and parking lights will be energized as long as the ignition is on. Even if it is light.

### Legi-Lite Mode

The Legi-Lite feature will turn on the parking lights and headlights immediately whenever the driver turns the windshield wipers on. For this feature to function, one of the (+ or -) wiper input wires must be connected to the vehicles windshield wiper circuit (see wiring connection guide).

## OPERATION TIME ADJUSTMENT

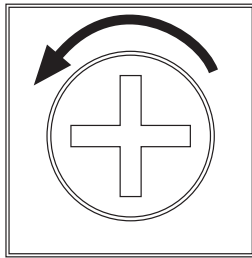

Rotate counterclockwise for less time

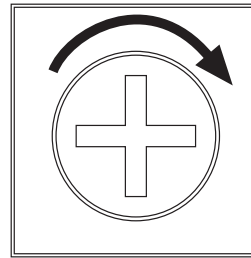

Rotate clockwise for more time

The amount of time that the Nite-Lite will operate when triggered by the security system can be increased or decreased by rotating the adjustment screw under the door on the module. The adjustment range is between 1 and 100 seconds.

## DAYTIME RUNNING LIGHTS

The 545T includes a daytime running lights mode. The unit is shipped with this feature enabled. Anytime the ignition is on, the headlights turn on. This feature only affects the headlights. The parking lights are still controlled by the photocell. This feature can be deleted by cutting the red loop located inside the unit.

**NOTE:** With multiplex controlled circuits, attempting to get the headlights and parking lights to function independently of each other is not recommended.