

PrecisionPower.

Absolutely State of the Art Mobile Audio.

4829 South 38th Street
Phoenix, Arizona
85040-2964 USA
1-800-62-POWER

PrecisionPower[®]

Absolutely State of the Art Mobile Audio[™]

Owner's Manual

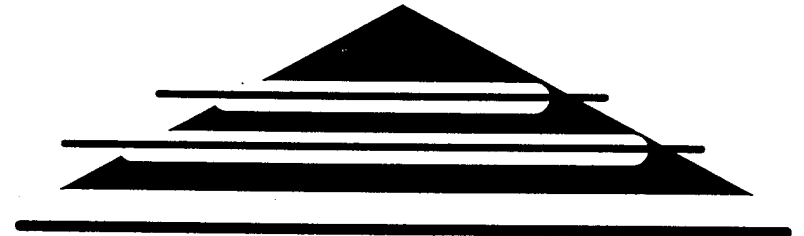

Sedona Series 50Q / 100iQX
200iQX / 500iQX / 430iQX / 460iQX



Designed and Handcrafted in the USA



CONGRATULATIONS AND THANK YOU for your choice of a Precision**Power**, Inc. high performance mobile audio amplifier. **PPI** is proud to be a world leader specializing in the design, engineering, and manufacture of "State of the Art" mobile audio electronics. Our success is derived from the fact that we do not incorporate gadgets or passing fads into our products. Sound engineering practice, combined with deceptively simple yet highly effective circuit designs, characterize every **PPI** product. Yet our demand for maximum value dictates every ounce of fat be trimmed if it does not contribute to sound quality or reliability. This is why Precision**Power** products have consistently enjoyed an unparalleled reputation for sound value. We are sure your new Sedona **iQX** amplifier will provide you with years of listening pleasure.

Important Safeguards

The following list of 'Important Safeguards' has been compiled to help you achieve optimum satisfaction and the highest quality performance from your new mobile audio amplifier. Please take the time to review these safeguards before operation and/or installation of your new Sedona amplifier.

Read Instructions

We all have a tendency to read instructions only after something doesn't work as anticipated. This manual provides specific information concerning the operation and installation of your new amplifier. Please read this manual thoroughly and retain it for future reference.

Keep Your Sales Receipt

Your **PPI** amplifier has a three-year limited warranty when it is installed by an Authorized **PPI** dealer. Non authorized dealer installed (**PPI**) amplifiers carry a one-year parts / ninety days labor limited warranty. To establish the starting date of warranty coverage, a copy of your sales receipt must accompany your amplifier for all warranty service. Please file your sales receipt away for future reference. For your convenience, a complete limited warranty statement is located at the back of this manual.

Follow Instructions

All use and installation instructions should be followed to assure proper operation of your new Sedona amplifier.

Heed All Wiring Requirements

A high-performance amplifier requires minimum wire gauges be used for the Power, Ground, Remote Turn-On, and Speaker cables. To assure proper operation of your Sedona amplifier, follow all wiring requirements.

Heed all Fusing Requirements

The fusing requirements of your Sedona amplifier have been established for its continued safe operation. Replacement with a higher value fuse may result in damage and voiding of warranty.

Installation Accessories

Sedona amplifiers will require non-supplied installation accessories. Please refer to the Installation Section of this manual for a list of requirements or consult your Authorized **PPI** dealer before installation.

Water and Moisture

Never mount your Sedona amplifier in a location which would subject it to immersion or exposure to water.

Servicing

Do not attempt to service this amplifier yourself. Opening or removing covers will void your warranty. For service information, consult your Authorized **PPI** dealer or call Precision**Power**, Inc. at **1-800-62-POWER**. Our customer service representatives are available Monday through Friday from 8am to 6pm Mountain Standard Time.



Caution!

The use of a high powered audio system may cause hearing loss or damage. While **PPI** systems are capable of "Concert level" volumes with incredible accuracy, they are designed for you to enjoy the subtleties created by musicians while listening at reasonable sound pressure levels. The use of a high powered audio system may impair your ability to hear traffic sounds and, therefore, may constitute a traffic hazard. We advise lower volume levels while driving.

Table of Contents

Features	
50Q	4
100iQX and 200iQX	5
500iQX	6
430iQX / 460iQX	7
Specifications	
50Q, 100iQX, 200iQX, and 500iQX	8
430iQX and 460iQX	9
Glossary of Terms	10
Installation	11
Adjusting the Internal Crossover	15
Changing the Crossover Frequency	19
QBass Adjustment	20
System Tuning	20
Troubleshooting	21
System Designs	22
Limited Warranty	26



Sedona 50Q Features

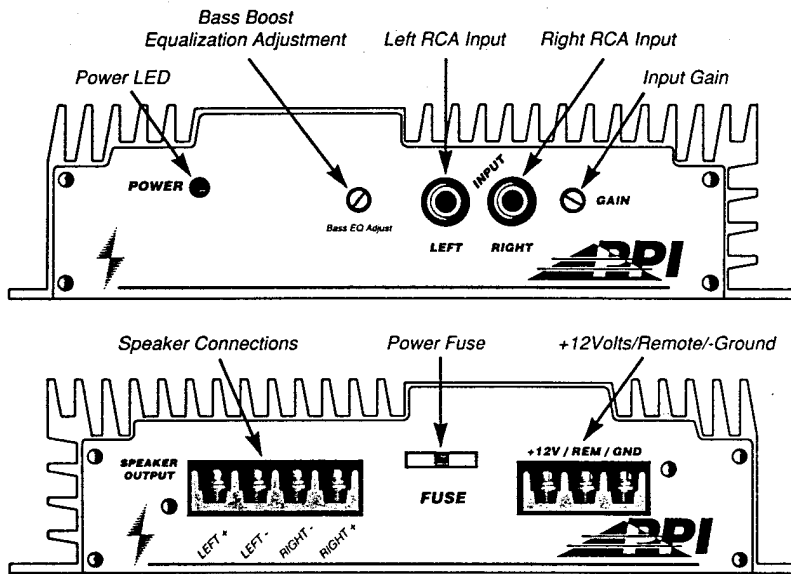

50Q Front / Rear End Plates

- MOSFET Switching Power Supply**
- Ultra-wide Bandwidth Circuitry**
- QBass Adjustment**
- Gold RCA Input Connectors**
- Output Short Circuit Protection with Diagnostic LED**
- Low Impedance Protection**
- Thermal Protection**
- Soft Start**
- Adjustable Input Sensitivity**
- Three-Year Warranty**
- Manufactured In The U.S.A.**

100iQX & 200iQX Features

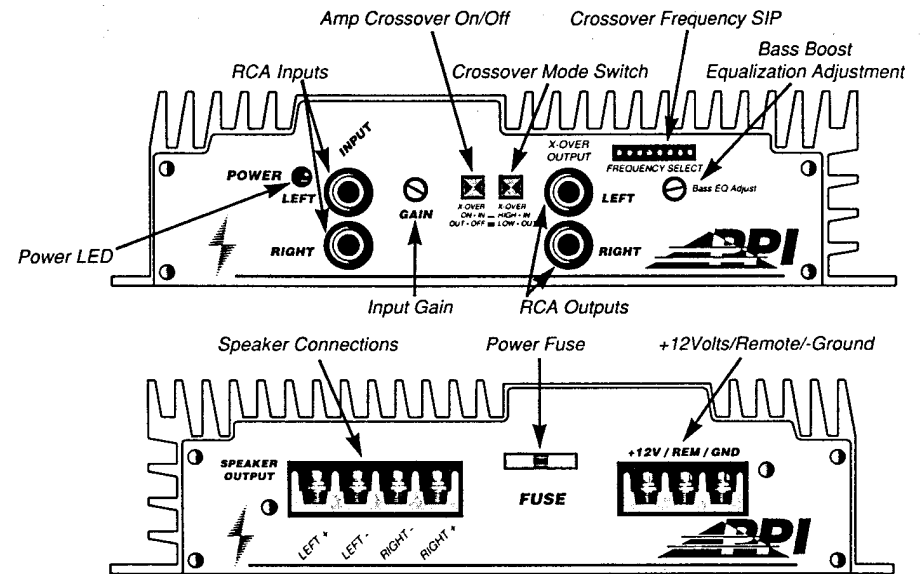

100iQX / 200iQX Front / Rear End Plates

- MOSFET Switching Power Supply**
- Ultra-wide Bandwidth Circuitry**
- QBass Adjustment**
- Gold RCA Input Connectors**
- Output Short Circuit Protection with Diagnostic LED**
- Low Impedance Protection**
- Thermal Protection**
- Soft Start**
- Adjustable Input Sensitivity**
- Adjustable Two-Way Electronic Crossover**
- Gold RCA Crossover Output Connectors**
- Three-Year Warranty**
- Manufactured In The U.S.A.**

Specifications

Sedona Two-Channel Amplifiers

Model	50Q	100iQX	200iQX	500iQX
<i>Continuous Output Power @ 14.4 Volts</i>				
Watts per Channel @ 4 Ohms	25 Watts	50 Watts	100 Watts	250 Watts
Watts per Channel @ 2 Ohms	45 Watts	90 Watts	165 Watts	350 Watts
Bridged Mono Output @ 4 Ohms	90 Watts	180 Watts	330 Watts	700 Watts
Power Bandwidth	10Hz to 50kHz	10Hz to 50kHz	10Hz to 50kHz	10Hz to 50kHz
Distortion (THD)	0.08%	0.08%	0.08%	0.08%
Signal-To-Noise Ratio	> 96 dB	> 96 dB	> 96 dB	> 96 dB
Damping Factor	>200	>200	>200	>200
Stereo Separation	>72 dB	>72 dB	>72 dB	>72 dB
Input Sensitivity	0.01 - 2.0V	0.01 - 2.0V	0.01 - 2.0V	0.01 - 2.0V
Input Impedance	10 kOhms	10 kOhms	10 kOhms	10 kOhms
Load Impedance	2 - 8 Ohms	2 - 8 Ohms	2 - 8 Ohms	2 - 8 Ohms
Load Impedance (Bridged)	4 - 8 Ohms	4 - 8 Ohms	4 - 8 Ohms	4 - 8 Ohms
Crossover	No	Yes	Yes	Yes
Supplied Crossover Frequency	N/A	90 Hz	90 Hz	90 Hz
Available Crossover Frequencies	N/A	20 Hz to 9 kHz	20 Hz to 9 kHz	20 Hz to 9 kHz
QBASS / +12dB @ 40Hz	Yes	Yes	Yes	Yes
RCA Crossover Outputs	No	Yes	Yes	Yes
Supply Voltage	14.4 Volts	14.4 Volts	14.4 Volts	14.4 Volts
Fuse	10 Amp	20 Amp	35 Amp	80 Amp
Dimensions (inches)	2 x 8.2 x 5.4	2 x 8.2 x 7.4	2 x 8.2 x 8.9	2 x 8.2 x 24

Specifications

Sedona Four-Channel Amplifiers

Model	430iQX	460iQX
<i>Continuous Output Power @ 14.4 Volts</i>		
Watts per Channel @ 4 Ohms	30 Watts	60 Watts
Watts per Channel @ 2 Ohms	50 Watts	100 Watts
Bridged Mono Output (Watts x 2 Ch) @ 4 Ohms	100 Watts	200 Watts
Power Bandwidth	10 Hz to 50 kHz	10 Hz to 50 kHz
Distortion (THD)	0.08%	0.08%
Signal-To-Noise Ratio	> 96 dB	>96 dB
Damping Factor	>200	>200
Stereo Separation	>72 dB	>72 dB
Input Sensitivity	0.01 - 2.0V	0.01 - 2.0V
Input Impedance	10 kOhms	10 kOhms
Load Impedance	2 - 8 Ohms	2 - 8 Ohms
Load Impedance (Bridged)	4 - 8 Ohms	4 - 8 Ohms
Two Crossovers	Yes	Yes
Supplied Crossover Frequency	90 Hz	90 Hz
Available Crossover Frequencies	20 Hz to 9 kHz	20 Hz to 9 kHz
QBASS / +12dB @ 40Hz	Yes	Yes
RCA Crossover Outputs	Yes	Yes
Supply Voltage	14.4 Volts	14.4 Volts
Fuse	20 Amp	40 Amp
Dimensions (inches)	2 x 8.2 x 10	2 x 8.2 x 12.5

Glossary

The following terms are used in this manual. Since they may be unfamiliar, the following definitions are provided.

Bridging	Combining two amplifier channels into one channel. Typically used to create a mono output.
Gain	The ratio of output voltage to input voltage. The gain control allows adjustment to the amplifier's output level for varying input levels.
L.E.D.	Light Emitting Diode. Indicates power on / off.
Load Impedance	Measurement of speaker(s) resistance / reactance that the amplifier must drive.
Mixed Mono	The amplifier's ability to play the Left and Right Stereo channels while playing a third (bridged) mono channel.
Remote Turn-On	Low current automatic switching circuit that turns the amplifier on and off. Typically connected to the remote antenna or amp turn-on lead of most car radios, cassettes, or CD players.
Low-Pass Filter	An electronic circuit which blocks frequencies above a pre-determined frequency. Frequencies below the cutoff are passed without effect.
High-Pass Filter	An electronic circuit which blocks frequencies below a pre-determined frequency. Frequencies above the cutoff are passed without effect.
"SIP"	Single In-line Package. This refers to the plug-in resistor module that sets the crossover frequency for the 100iQX, 200iQX, 500iQX, 430iQX, and 460iQX.
QBASS or BassBoost	A variable gain adjustment which boosts the preset 40Hz frequency up to 12dB.

Installation

PRIOR TO INSTALLATION of your new Sedona iQX amplifier, it is important to consider the following: In your profession, your abilities and expertise insure a job well done. Trained professional car audio installers are no different. It's their chosen profession and what they do best. **PPI** believes so strongly in its responsibility to you, that we invest heavily in the hands-on training of professional installers. Our comprehensive system design / installation seminar provides our authorized dealers with the latest techniques to deal with the complexities of car audio today. There is more than meets the eye to insure that a car stereo reaches its fullest potential. The trained professional, through experience, can approach, recognize, and address all the needs of the mobile audio environment. **PPI** highly recommends that this amplifier and/or any other mobile audio equipment be installed by a trained professional.

Tools / Parts Needed for Installation (not supplied):

Small flat blade screwdriver	Phillips screwdriver
Wire cutters	Wire strippers
Soldering iron	Solder
Flux cleaner	5 washers, 4 #6 and 1 #8 sheet metal screws
1 - ring connector	3 Spade Connectors
Speaker wire – 16 gauge or larger	Power and Ground wire – 12 gauge or larger
Heat shrink	Grommets
Silicone or similar material	In-line fuse holder and fuse

Mounting

To prevent damage to the amplifier while driving, mount it in a secure place. Choosing the appropriate location will depend upon your vehicle and the complexity of your system design. It may be mounted in any compatible space that is convenient to your needs and provides sufficient airflow. Adequate ventilation allows the amplifier to dissipate the heat that develops during operation. Inadequate ventilation may result in overheating. The thermal protection circuit will shut the amplifier off when the heatsink temperature reaches 75 degrees Celsius. The amplifier will automatically return to operation once the heatsink cools.

Typical mounting locations include: trunk and passenger compartment (floor or seat). Never mount the amplifier in a location which would subject it to immersion or exposure to water.

The PrecisionPower Sedona heatsink is designed for high-efficiency cooling, but improper mounting may compromise its ability to cool. When mounting the amplifier in a confined space (i.e. under seat), care must be taken to ensure that at least two inches' of clearance is provided around the amplifier. If the amplifier is located in an area which has restricted air-flow or is totally enclosed, a fan may be used to improve air circulation.

+12 Volts / Remote / -Ground

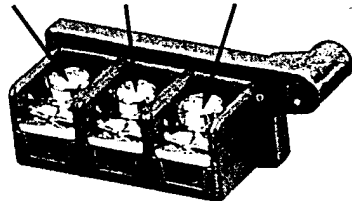

Sedona 50Q / 100iQX / 200iQX / 500iQX / 430iQX / 460iQX
Power / Remote-Turn on / Ground Connector

Power, Remote Turn-On, and Ground

Before beginning, disconnect the negative (-) terminal of the battery prior to working on the positive terminal to prevent a short to ground. Reconnect the negative terminal only after all connections have been made.

Sedona iQX amplifiers are designed to operate from a car's (+) positive 12 volt, negative ground electrical system. The power and ground cables should be a minimum of 12 gauge. Depending upon the complexity of your system, larger gauge wire may be needed.

The main power cable should run from the amplifier location, through the vehicle to the battery, avoiding sharp corners, creases, and sharp body parts. When passing through any metal wall (i.e. fire wall etc.), a grommet must be used to prevent the wire from chafing and shorting to ground. For safety reasons, **PPI** recommends that the power cable be fused at the positive terminal of the battery. If this fuse is not installed, and the power wire shorts to ground (between the battery and the amplifier), a fire can result. The fuse at the battery should be of the same value as the chassis fuse located on the rear endplate of the amplifier. Consult your Authorized **PPI** Dealer for an appropriate in-line fuse holder that meets the needs of your installation. We suggest crimping and soldering all wire connections. Insulate the connection with heat shrink to prevent a short to ground.

The ground wire should be of the same gauge as the power wire. As a 'rule of thumb', use as short a length of wire as possible. Locate an area near the amplifier that is metal (the floor is ideal) and clean an area about the size of a quarter to bare metal. Drill a pilot hole in the middle of this area. **Be Careful!** Inspect the area underneath to be sure you aren't drilling into wires, brake or fuel lines, etc. Terminate the wire with a ring connector and attach it to the bare metal using a # 8 sheet metal screw and washer (not supplied). We suggest crimping and soldering this connection. Insulate the connection with heat shrink. It is important that this connection be solid. After the connection is complete, coat the area with silicone or some similar material to prevent rust from developing.

Once you have run both the power and ground wires, it's time to connect the cable to the amplifier. Be sure that you have not reconnected the ground cable to the negative post of the battery. Cut off excess wire and terminate the wire with a spade connector. We suggest crimping and soldering this connection. Insulate the connection with heat shrink. Locate the Power/Remote/Ground terminal strip on the rear endplate. With a small flat bladed or Phillips head screw driver, loosen the terminal screws. Insert each wire and secure it by tightening the associated screw. Be sure each connection is tight.

Remote Turn-On

In order for the amplifier to turn on, a remote turn-on wire must be connected to a switched 12 volt source. Typically, the source unit provides a power antenna (remote) turn-on lead which will turn on the amplifier when the source unit is activated. If this is unavailable, a switched 12 volt source must be used.

Run a wire from the amplifier location through the vehicle to the switched 12 Volt source. Observe the same precautions for routing this cable that you followed for running the power cable. Cut off excess wire and terminate the wire with a spade connector. We suggest crimping and soldering this connection. Insulate the connection with heat shrink. It is important that this connection be solid. With a flat bladed or Phillips head screw driver, loosen the terminal screw on the barrier strip. Insert the spade connector into the appropriate location and secure it by tightening the associated screw. Be sure the connection is tight.

Left Channel + Left Channel - Right Channel - Right Channel +

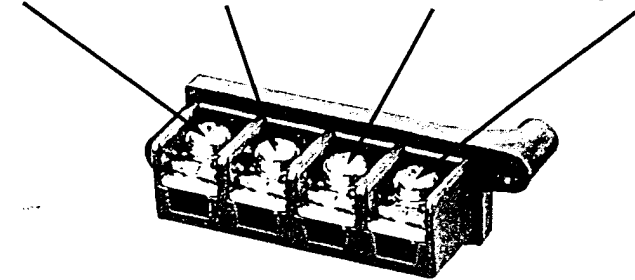

Speaker Connection

Run the speaker wires from the amplifier location through the vehicle to the speakers. Observe the same precautions for routing these wires that you followed for running the power and remote turn-on cables. It is important to use 16 gauge or larger wire for proper signal transfer. Cut off excess wire and terminate the wire with a spade connector. We suggest crimping and soldering this connection. Insulate the connection with heat shrink. Locate the speaker terminal strip on your iQX amplifier. Loosen the screws on the connector. Insert the speaker leads, one at a time, into the appropriate screw on the terminal strip. Check to make sure you've maintained proper polarity before securing each wire. Be sure the connection is tight.

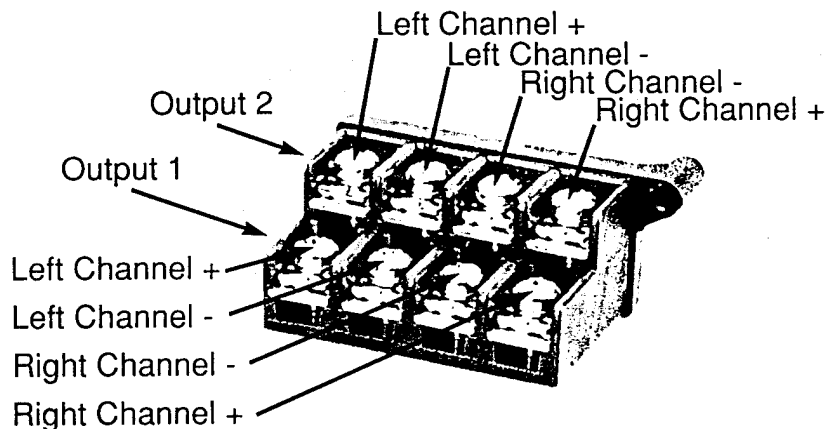

Bridging

All Sedona **iQX** amplifiers are capable of being bridged into a mono output due to the internal design of the amplifier. This feature permits the creation of a mono channel for a subwoofer or center channel. Also, bridging adds flexibility of operation. Any of the Sedona **iQX** two-channel amplifiers can be used in a one channel (mono), two channels stereo, or 3 channels – 2 channels stereo and one channel mono configuration. The Sedona **iQX** four-channel amplifiers can be used as 2 mono channels, 3 channels – 2 channels stereo and one channel mono, 4 channels – 2 channels front and rear, 5 channels – 4 channels stereo and one channel mono, or 6 channels – 4 channels stereo and 2 channels mono.

Deriving the mono channel is accomplished by using the left channel positive wire as the positive speaker wire and the right channel negative wire as the negative speaker wire. It is important that a minimum 4 Ohm impedance is observed.

The ability to run stereo satellites while simultaneously running a mono output from the same output stage is accomplished simply by running the stereo speakers normally and tapping into the appropriate wires for the 'Mixed Mono' channel (left channel positive wire as the positive speaker wire and the right channel negative wire as the negative speaker wire). Again, speaker impedance should not be lower than 2 Ohms on the stereo channels and 4 Ohms on the mono channel.

Inputs

On the front end plate of the 50Q, 100iQX, 200iQX, and 500iQX are a set of RCA low-level signal input jacks. The 430iQX and 460iQX have 4 RCA inputs which are labeled Input 1 and Input 2. Connect a source unit (head unit, equalizer, crossover, etc.) to these inputs.

It is important to note that the input signal on the 100iQX, 200iQX, 500iQX, 430iQX, and 460iQX may be routed through the amplifier's internal crossover. Engaging the internal crossover is accomplished by using the switches located next to the RCAs on the endplate. Refer to the section labeled **Adjusting the Internal Crossover** for more detailed information.

Gain Control

On the front end plate, next to the inputs, is the gain control. It can be adjusted using a small flat blade screwdriver. **Upon installation of the amplifier, the gain control must be adjusted.** This can be done by first turning the gain all the way down (counter clockwise). Turn the volume on the source unit up two thirds. Then adjust the gain control until the desired volume is obtained without audible distortion.

Adjusting the Internal Crossover

The 100iQX, 200iQX, 500iQX, 430iQX, and 460iQX have integrated two-way electronic crossovers. The integrated crossover allows the 100iQX, 200iQX, & 500iQX to be operated in three modes: 2 channels full-range, 2 channels high-pass, or 2 channels low-pass. The 430iQX and 460iQX may, also, be operated in three modes: 2 channels high-pass / 2 channels low-pass, 4 channels high-pass or 4 channels low-pass with Bass Boost. Integral to the design of these five amplifiers is a set of RCA line level outputs. These outputs are always active and available to send either a low-pass with variable bass boost signal or high-pass signal (100iQX, 200iQX, & 500iQX). High-pass or low-pass without QBass to another amplifier (430iQX / 460iQX). Changing the two SIP values in a Sedona four channel amp to 20Hz, will allow the amplifier to be played in full range.

The crossover features 12 dB per octave slopes and is shipped with a 90 Hz crossover SIP installed. The crossover frequency may be changed by removing and replacing the resistor 'SIP' found on the front end plate. The crossover resistor 'SIPs' are available (from your authorized Precision**Power** dealer) in the following frequencies: 20 Hz, 30 Hz, 60 Hz, 70 Hz, 90 Hz, 110 Hz, 130 Hz, 160 Hz, 190 Hz, 230 Hz, 320 Hz, 390 Hz, 590 Hz, 880 Hz, 1300 Hz, 1600 Hz, 2700 Hz, 3200 Hz, 4000 Hz, 5300 Hz, 6000 Hz, and 9000 Hz.

Operation / Set-Up of the internal crossover in the Sedona two-channel **iQX** amplifiers differs from that of the four-channel **iQX** amplifiers, and we have divided this section to address each product group separately. Please refer to the appropriate section for your particular amplifier.

100iQX, 200iQX, and 500iQX

As previously mentioned, the two-channel Sedona **iQX** amplifiers offer three modes of operation: 2 channels full-range, 2 channels high-pass, or 2 channels low-pass with adjustable bass boost. The two buttons labeled: **X Over (On/Off) and X Over (High/Low)**, located on the front end plate, control the operation of the internal crossover. In the 'Off' (out) position, the input signal bypasses the internal crossover and the amplifier's output is full-range. When this switch is in the 'On' (in) position, the input signal passes through the internal crossover, and the **X Over (High/Low)** switch determines if the amplifier will produce a high-pass or low-pass output.

The RCA outputs are connected to the internal crossover and are always active. Their signal (high-pass or low-pass) is controlled by the X Over (High/Low) switch. It is important to note that the signal available at the RCA outputs is always opposite of that set for the internal amplifier when the crossover switch is on. For example: If the X Over (High/Low) switch is set to High, the amplifier will produce a high-pass signal and the RCA outputs will deliver a low-pass signal. Conversely, if the X Over (High/Low) switch is set to Low, the amplifier will produce a low-pass signal, and the RCA outputs will deliver a high-pass signal.

Please Note: When the 100iQX, 200iQX, or 500iQX are set to operate in the full-range mode (X Over (On/Off) switch in the Out position), the RCA outputs can deliver either a low-pass or high-pass signal depending upon the position of the X Over (High/Low) switch.

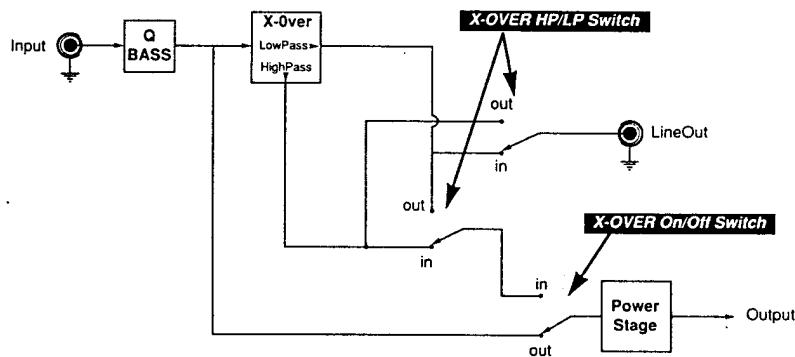

100iQX, 200iQX, & 500iQX Signal Flow Chart (one channel shown)

The following chart represents the various modes of operation and the associated crossover switch positions for the 100iQX, 200iQX, and 500iQX. We suggest that you refer to this chart prior to setting up your system.

100iQX, 200iQX, & 500iQX Modes of Operation			
X-OVER Switches	Output		
	On/Off	High/Low	LineOut RCAs
OUT	OUT	Full-Range w/Bass Boost	High-Pass
IN	OUT	Low-Pass w/Bass Boost	High-Pass
OUT	IN	Full-Range w/Bass Boost	Low-Pass w/Bass Boost
IN	IN	High-Pass	Low-Pass w/Bass Boost

430iQX & 460iQX

The 430iQX and 460iQX may be configured in many ways. Some examples are channels high-pass and 2 channels low-pass, 4 channels high-pass, 4 channels low-pass (for dual-bridged subwoofer use), etc. Refer to the modes of operation chart a complete list of options. The two buttons labeled: X Over 1 and X Over 2 located on the front end plate control the operation of the internal crossovers. The Input (Combined) button selects whether a single pair (left and right) of RCA cables will be used (button "in"), or two sets (a front pair and a rear pair) will be used (button "out").

Note: Whenever Front to Rear fade capability is required, be sure that the Input (In-Combined) and X Over 2 buttons are in the "out" position.

The X-Over 1 (in-HP/Out-LP) button selects whether the high-pass or low-pass signal from X-Over 1 will be available at output 1. With the button "in" the high-pass signal will be sent to output 1 and no bass EQ will be utilized. With the button in the "out" position, the low-pass signal will be sent to output 1 and the Bass Boost control can be utilized.

The X-Over 2 (in-Combine X-Overs/ out-HP) button selects whether Output 2 provided with a signal from X-Over 1, or X-Over 2. With the button pushed "in", the signal from X-Over 1 (high-pass or low-pass) is sent directly to Output 2 allowing single pair of RCA cables to drive all of the amplifiers outputs. With the button in the "out", the high-pass output of X-Over 2 is available at Output 2.

Note: By having the X-Over 2 button in the "out" position, different crossover pairs can be selected for the front and rear channels. By setting X-Over 1 to one frequency and X-Over 2 to a different frequency, output 1 will reproduce high-pass frequencies selected by X-Over 1, and Output 2 will reproduce high-pass frequencies selected by X-Over 2.

The X-Over Output (In-HP/Out-LP) button selects whether the high-pass or low-pass output from X-Over 1 will be made available at the RCA outputs. Pushing the button to the "in" position will provide a high-pass signal, and pushing the button to the "out" position will provide a low-pass signal with no bass boost.

The following Signal Flow Chart and Modes of Operation matrix represent the various configurations and associated button positions for the 430iQX and 460iQX. We suggest you refer to these charts prior to setting up your system.

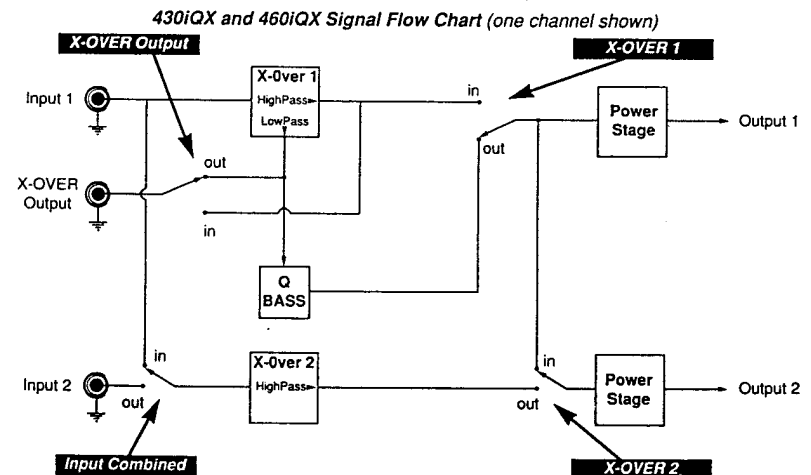

430iQX / 460iQX Modes of Operation

X-OVER Switches		Output 1		Output 2		Set-up Notes for Output 2
Input/Combine	X-OVER1	X-OVER2	Output 1	Output 2		
IN	IN	IN	HP	HP		using X-OVER 1 and Input 1 (Non-fading)
IN	IN	OUT	HP	HP		using Input 1 (combine switch) and X-OVER 2 (Non-fading)
IN	OUT	IN	LP w/Bass Boost	LP w/Bass Boost		using Input 1 and X-OVER 1 (Non-fading)
IN	OUT	OUT	LP w/Bass Boost	HP		using Input 1 (combine switch) and X-OVER 2 (Non-fading)
OUT	IN	IN	HP	HP		using Input 1 and X-OVER 1 (Non-fading)
OUT	OUT	IN	LP w/Bass Boost	LP w/Bass Boost		using Input 1 and X-Over 1 (Non-fading)
OUT	IN	OUT	HP	HP		using Input 2 and X-OVER 2 (Fader Capability)
OUT	OUT	OUT	LP w/Bass Boost	HP		using Input 2 and X-OVER 2 (Fader Capability)

X-OVER Output Switch		X-Over Output RCAs
Switch Position		
IN		High-Pass
OUT		Low-Pass

Changing the Crossover Frequency

The 100iQX, 200iQX, 500iQX, 430iQX, and 460iQX are shipped from the factory with a 90 Hz Crossover Frequency Module (CFM) installed. To change this frequency module ('SIP'), simply remove the resistor 'SIP', located on the front end plate. Replace it with the appropriate 'SIP' value to achieve the desired frequency.

Note: Changing the two SIP values in a Sedona four channel amp to 20Hz, will allow the amplifier to be played in full range.

The following chart details **PPI's** CFM part number, 'SIP' value, and the associated

SIP Value / Frequency

8x - 2 - 563

The last three digits indicate the value of the SIP. Reference these numbers to the chart below to determine the frequency.

frequency value. Please refer to this chart before setting up your system.

PPI Part #	SIP Value	Frequency
CFM.0020	564	20 Hz
CFM.0030	334	30 Hz
CFM.0060	184	60 Hz
CFM.0070	154	70 Hz
CFM.0090	124	90 Hz
CFM.0110	104	110 Hz
CFM.0130	823	130 Hz
CFM.0160	683	160 Hz
CFM.0190	563	190 Hz
CFM.0230	473	230 Hz
CFM.0320	333	320 Hz
CFM.0390	273	390 Hz
CFM.0590	183	590 Hz
CFM.0880	123	880 Hz
CFM.1300	822	1300 Hz
CFM.1600	682	1600 Hz
CFM.2700	392	2700 Hz
CFM.3200	332	3200 HZ
CFM.4000	272	4000 Hz
CFM.5300	202	5300 Hz
CFM.6000	182	6000 Hz
CFM.9000	122	9000 Hz

QBass Adjustments

Precision**Power** Sedona Series **iQX** amplifiers now include a Bass EQ Adjust potentiometer on the end plate of your new amplifier. This control provides up to 12dB of boost at 40 Hz. Using a flat blade screw driver, turn the Bass EQ Adjust potentiometer clockwise to increase the boost and/or counterclockwise to decrease the boost.

System Tuning

In order to achieve maximum signal-to-noise performance from a high quality mobile sound system, it is desirable to use high signal levels wherever possible in the interconnection cables. High signal levels will reduce the effect of induced noise. The peak level of an audio signal is usually determined by the clipping level of electronic components. The following procedure should be used as a guide when the system installation is complete.

Adjusting Equalizer Input Gains:

1. Turn the equalizer's volume control to minimum.
2. Turn the source unit volume 1/2 to 3/4 of maximum. If available on your unit, set the output level to maximum. Some units may have a switch.
3. If available, set selector switch to either input 1 or input 2.
4. Adjust all equalizer input gains to minimum.
5. For the chosen input, play the respective music source. A loud music passage is desired.
6. For the chosen input, increase the left input gain control until the onset of audible distortion. Then decrease the gain prior to the immediate point of audible distortion. This setting will minimize system background noise and prevents overloading of the equalizer. Adjust, for the same input, the right input gain control for proper left / right balance.
7. Set selector switch to the alternative source unit, if used, and repeat steps 5 and 6.
8. Adjust crossover next.

Adjusting Crossover Input Gains:

1. Adjust all crossover gain controls to 0 dB, 1/2 of maximum sensitivity.
2. Adjust all amplifier gains to 1/2 of maximum sensitivity.
3. Turn the volume knob on the equalizer to a maximum of 3 o'clock.
4. Increase the gain of the crossover until the onset of audible distortion. Then decrease the gain prior to the immediate point of audible distortion. This setting will minimize system background noise and prevents overloading of the crossover.
5. Repeat step 4 for any remaining crossovers in the system.
6. Adjust the input gains next.

NOTE: In many multi-crossover/accessory systems, the gain of some crossover and accessories may need to be further decreased to achieve proportional balance.

Adjusting the Amplifier's Input Gain:

1. Adjust the amplifier's input gain to 1/2 maximum sensitivity.
2. Turn the volume knob on the source unit to a maximum of 3 o'clock.
3. Increase the gain (clockwise) until the onset of audible distortion. Then decrease the gain counterclockwise prior to the immediate point of audible distortion. This setting will minimize system background noise and prevents overloading of the amplifier.
4. Repeat step 3 for any remaining amplifiers in the system.

NOTE: Depending on the sensitivity of the system's preamp (s), the gain of the amplifier (s) may not need adjustments. Also, in many multi-amplifier systems, the gain of some amplifiers may need to be further decreased to achieve proportional balance.

Troubleshooting

If for some reason your system fails to operate properly, please refer to this guide. If you are unable to resolve the problem, consult your Authorized **PPI** Dealer or call **1-800-62-POWER**.

NO SOUND

Is the power LED illuminated?

Check fuses in power wire.

Be sure turn-on lead is connected.

NO SOUND IN ONE CHANNEL

Check speaker leads and inspect for a short to ground or an open connection.

Check pre-amp leads. Reverse left and right leads to see if the problem is before the amplifier.

Check Mono Bridge and Bi-Amp crossover switches on other units prior to the amp.

If the problem is in the amp, have your **PPI** Dealer inspect the unit.

AMP TURNING OFF

Is the amp able to cool properly?

Check speakers for shorts or damage.

Make sure power and ground are secure.

Locate proper ground potential with a meter.

Have **PPI** Dealer inspect amp.