

OPERATOR'S MANUAL

**ProMOS-425 ProMOS-450**

**Precision Power**

**Professional MOSFET Amplifiers**  
**MADE IN THE U.S.A.**

4829 South 38th Street  
Phoenix, Arizona 85040-2964  
• U.S.A. •  
602 - 437 - 5207  
1-800-62-POWER

**Precision Power**

**Professional MOSFET Amplifiers**

MADE IN THE U.S.A.

## TABLE OF CONTENTS

FEATURES .....	2
GLOSSARY .....	3
SPECIFICATIONS .....	4
INTRODUCTION .....	5
INSTALLATIONS .....	6
CONTROLS .....	9
MOUNTING .....	10
SYSTEM GAIN ADJUSTMENTS .....	11
SAMPLE HOOKUP CONFIGURATIONS .....	13
TROUBLESHOOTING .....	15
LIMITED WARRANTY .....	17

## GLOSSARY

The following terms are used within this manual. Since they may be unfamiliar, definitions are provided as follows.

<b>Bridging</b>	Combining two amplifier channels into one channel.
<b>Gain</b>	The ratio of output voltage to input voltage. The gain control allows adjustment to the amplifier's output level for varying input levels.
<b>LED</b>	Light Emitting Diode. Usually indicates power on/off and/or signal overload.
<b>Load Impedance</b>	Measurement of speaker(s) resistance/reactance that the amplifier must drive.
<b>Phantom Power</b>	Power supplied to PPI accessories through a Precision Power amplifier via the DIN cables.
<b>Remote Turn-On</b>	Low current automatic switching circuit which is connected to a power antenna lead and to the amplifier(s) via the blue wire on the speaker harness.

## SPECIFICATIONS

	ProMOS-425	ProMOS-450
Continuous Power Output (Watts per channel into 4 Ohms @ 12V, Stereo)	25 W	50 W
(Watts into 4 Ohms @ 12V, Bridged)	100 W	200 W
(Watts per channel into 2 Ohms @ 12V, Stereo)	50 W	100 W
(Watts into 2 Ohms @ 12V, Bridged)	200 W	400 W
Dimensions (H x W x D)	2.1" x 8" x 9"	2.1" x 8" x 14"
Fuse	25 A	35 A

### Common Specifications

Power Bandwidth (±1 dB)	10 Hz - 50K Hz
Total Harmonic Distortion (Per IHF A-202)	0.02%
Signal-to-Noise Ratio (A-weighted)	102 dB
Damping Factor (100 Hz)	>500
Stereo Separation	>72 dB
Input Sensitivity	0.30 - 2.0V
Input Impedance	10K Ohms
Output Impedance (Stereo)	1 - 8 Ohms
Output Impedance (Bridged)	2 - 8 Ohms
Supply Voltage	10.5 - 16 VDC

## INTRODUCTION

Precision Power's ProMOS-425 and ProMOS-450 are a comprehensive line of amplifiers made to perform flawlessly. Utilizing the features available the sound quality and reliability are endless. These amplifiers feature a switching power supply, over-current protection, high current capabilities, and internal bridging. The ProMOS series is an eloquent solution for the rigorous demands of the hostile environment of auto-sound competition. They will perform even under the worst conditions. The switching power supply and high-current capabilities enable the use of higher output power. To protect the internal circuitry of the amplifier and the speakers an output over-current protection has been added. The internal bridging capabilities allows versatility in hosting several different speaker configurations. For further information in this area refer to the Sample Hookup Configurations within this manual.

FIG. A Power Wiring

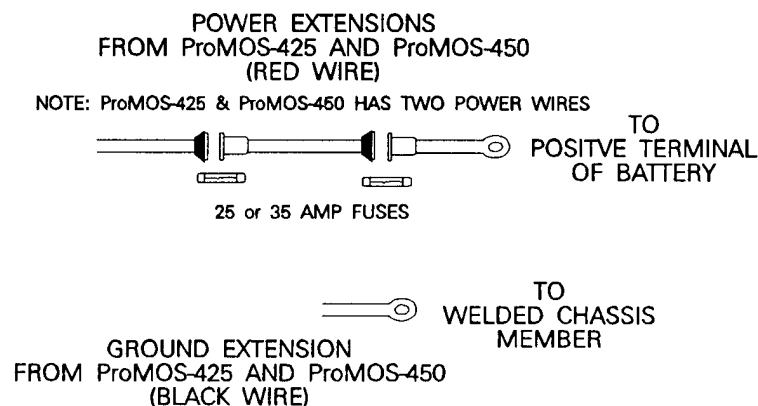

## INSTALLATIONS

### POWER

**Disconnect the negative post of the battery before working on the positive terminal to prevent a short to ground. Reconnect the negative terminal only after all connections have been made.**

The ProMOS-425 and ProMOS-450 are powered from the vehicle's 12-volt battery or any standard 12-volt DC supply, and a remote switching +12 volt source for turn-on. These connections are color coded as follows:

+12 Volts ..... Red Wire  
Chassis Ground ..... Black Wire  
Remote Turn-On ..... Blue Wire

The ProMOS-425 and ProMOS-450 are shipped with two 10 gauge red, primary power harness which includes four inline fuse holders. Two are mounted near the amplifier and the other two near the positive terminal of the battery. (Refer to Fig. A) These offer protection from a short to the chassis and additional protection to the amplifier's internal circuitry. The power harnesses are terminated with a large ring for connection directly to the positive terminal of the battery. After these connections are made insert both fuses to the amplifier and the long power wires (25 Amps provided for the ProMOS-425 and 35 Amps provided for the ProMOS-450). Route these wires, avoiding sharp corners, creases, and sharp car body parts to the battery fuse holder. Cut off excess wire and slip on the black fuse caps (provided). Using wire strippers (not provided), strip the power wires 1/8 inch. Insert the stripped wires into the silver rivet caps (provided) and solder thoroughly. After the solder cools, clean the remaining flux from the rivet caps and insert the fuses that are provided with your amplifier (25 Amps or 35 Amps).

The amplifier now needs to be grounded with the 10 gauge black wire that extends from the amplifier's chassis. This wire is also terminated with a ring for easy connection. The ground wire should be connected to a welded chassis member. When connecting, use a #8 sheet metal screw (not provided), being sure to remove any paint from the surrounding metal. **DO NOT** lengthen the ground wire. Failure to adhere to this procedure may result in system noise.

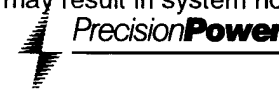

## REMOTE TURN-ON

In order for the amplifier to turn on, the Remote Turn-On wire (blue wire located on the speaker harness) must be connected to the power antenna lead. (Refer to Fig. B) If this lead is unavailable a separate switch must be used. This switch will need to be connected to the +12-volts of the battery. This will allow your amplifier to shut on and off with the car.

If the ProMOS-425 and/or ProMOS-450 does not power up, contact your dealer or Precision Power at 1-800-62-POWER for assistance.

## SPEAKER WIRING

All speaker connections are provided with a harness. (Refer to Fig. B) The harness connection is located on the right side panel of the ProMOS-425 and ProMOS-450. (Refer to Fig. C) If extra wire is needed, always use 16 gauge or larger wire. **NEVER CONNECT ANY SPEAKER LEAD TO THE CAR CHASSIS OR TO ANOTHER LEAD.**

For optimum performance, speaker impedances should be 2 Ohms or greater, either bridged or stereo. The Sample Hookup Configurations will help to show how this may be accomplished.

FIG. B Speaker Harness

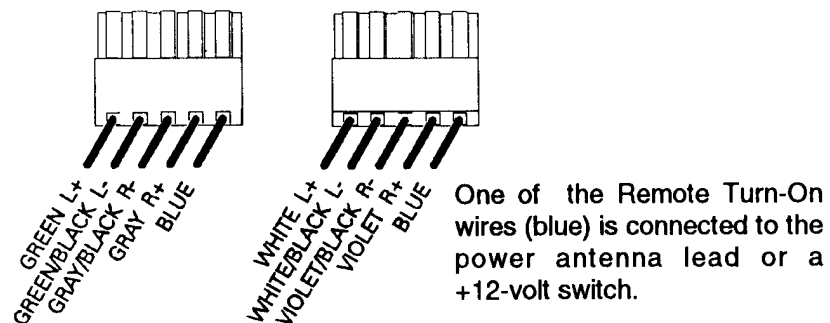
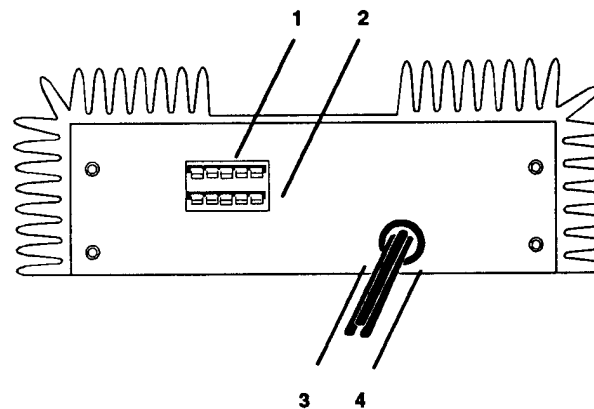

FIG. C Right Side Panel of the ProMOS-425/ProMOS-450



1. Front Speaker Output
2. Rear Speaker Output
3. Two Red Power Wires (+12-Volts)
4. Black Ground Wire (Chassis Ground)

## INPUTS

On the left side panel of the ProMOS-425 and ProMOS-450 amplifiers (Refer to Fig. D) are two sets of RCA-jacks, front and rear. A DIN-jack is paralleled to the inputs utilizing PPI's flexibility and convenience. This DIN-jack can be used to Phantom power other PPI accessories, such as our crossovers and equalizers.

## CONTROLS

### GAIN

The gain controls are located on the left side panel of the ProMOS-425 and ProMOS-450 amplifiers. (Refer to Fig. D) These controls require a small flat blade screwdriver to be adjusted. The gain determines the output signal level the amplifier produces. Too much gain can overload the speakers and produce distortion.

## TOOLS REQUIRED FOR INSTALLATION

- \* Small Flat Blade Screwdriver
- \* Wire Cutters
- \* Soldering Iron
- \* Flux Cleaner\*\*
- \* #8 Metal Screw per amp
- \* Phillips Screwdriver
- \* Wire Strippers
- \* Solder\*\*
- \* 4 Washers and Screws per amp\*\*

\*\* we suggest: water soluble solder, water to clean flux, and #6 Metal Screws for securing amp.

FIG. D Left Side Panel of the ProMOS-425/ProMOS-450

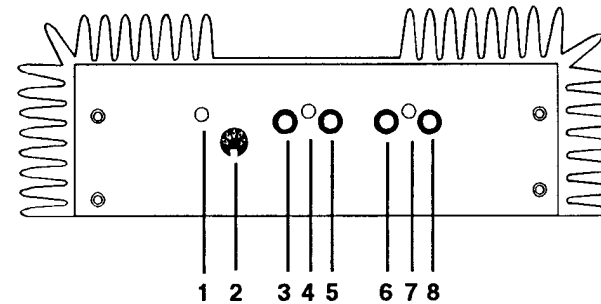

- |                         |                          |
|-------------------------|--------------------------|
| 1. Power Indicator      | 5. Right Rear RCA Input  |
| 2. Din Input            | 6. Left Front RCA Input  |
| 3. Left Rear RCA Input  | 7. Front Gain Adjustment |
| 4. Rear Gain Adjustment | 8. Right Front RCA Input |

## MOUNTING

To prevent damage to the amplifier while driving, mount it in a secure place. It may be mounted in any compatible space that is convenient to your needs. Keep in mind, the demanding life of an amplifier causes an increase in temperature the longer and harder it is working. Therefore, place the amplifier where there is sufficient air ventilation. Secure with #6 metal screws (not provided).

## SYSTEM GAIN ADJUSTMENTS

In order to achieve maximum signal-to-noise performance from a high quality auto stereo system, it is desirable to use high signal levels wherever possible in the interconnection cables. High signal levels will reduce the effect of induced noise. The peak level of an audio signal is usually determined by the clipping level of electronic components. The following procedure should be used as a guide when the system installation is complete.

### Adjusting equalizer input gains:

1. Turn the equalizer's volume control to minimum.
2. Turn source unit volume 1/2 to 3/4 of maximum. If available on your unit, set the output level to maximum. Some units may have a switch.
3. If available, set selector switch to either input 1 or input 2.
4. Adjust all equalizer input gains to minimum.
5. For the chosen input play the respective music source, such as a cassette, CD, or FM station. A loud music selection is desired.
6. For the chosen input, increase the left input gain control until the onset of audible distortion. Then decrease the gain prior to the immediate point of audible distortion. This setting will minimize system background noise and prevents overloading of the equalizer. Adjust, for the same input, the right input gain control for proper left/right balance.
7. Set selector switch to the alternate source unit, if used, and repeat steps 5 and 6.
8. Adjust crossover next.

## SYSTEM GAIN ADJUSTMENTS

### Adjusting crossover input gains:

1. Adjust all crossover's gain control(s) to 0dB, 1/2 of maximum sensitivity.
2. Adjust all amplifier gains to 1/2 of maximum sensitivity.
3. Turn the volume knob on the equalizer to a maximum of 3 o'clock.
4. Increase the gain of the crossover until the onset of audible distortion. Then decrease the gain prior to the immediate point of audible distortion. This setting will minimize system background noise and prevents overloading of the crossover.
5. Repeat step 4 for any remaining crossovers in the system.
6. Adjust the ProMOS-425 and/or ProMOS-450 input gains next.

NOTE: In many multi-crossover/accessory systems, the gain of some crossovers/accessories may need to be further decreased to achieve proportional balance.

### Adjusting ProMOS-425 and/or ProMOS-450 Input gains:

1. Adjust all amplifier gains clockwise to 1/2 of maximum sensitivity.
2. Turn the volume knob on the equalizer to a maximum of 3 o'clock.
3. Increase the gains clockwise until the onset of audible distortion. Then decrease the gains counterclockwise prior to the immediate point of audible distortion. This setting will minimize system background noise and prevents overloading the ProMOS-425 and/or ProMOS-450.
4. Repeat step 3 for any remaining amplifiers in the system.

NOTE: Depending on the sensitivity of the system's preamp(s), the gain of the amplifier(s) may not need adjustments. Also, in many multi-amplifier systems, the gain of some amplifiers may need to be further decreased to achieve proportional balance.

## SAMPLE HOOKUP CONFIGURATIONS

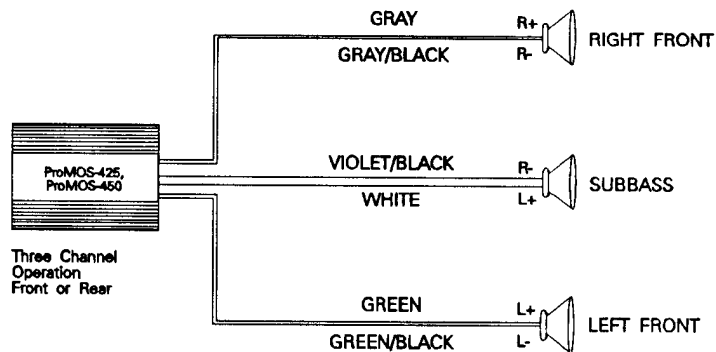
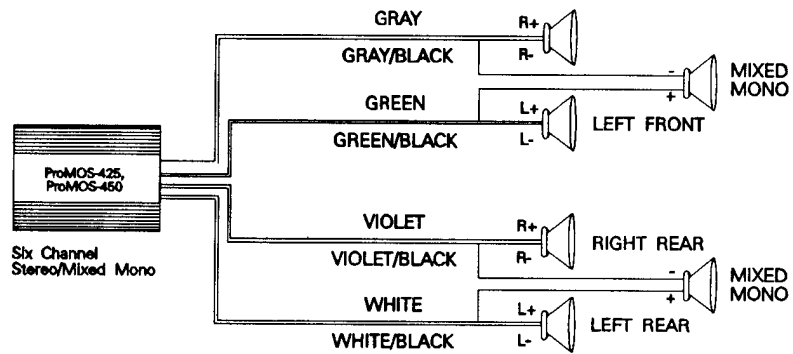

NOTE: When utilizing the mixed mono design format, impedance loading is extremely important and an appropriate passive crossover network is recommended. Consult your Precision Power authorized dealer or call Precision Power at 1-800-62-POWER.

The minimum recommended impedance loads are as follows:

STEREO: 1 Ohm

BRIDGED: 2 Ohms

## SAMPLE HOOKUP CONFIGURATIONS

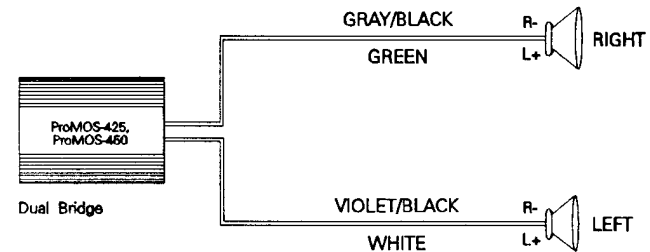
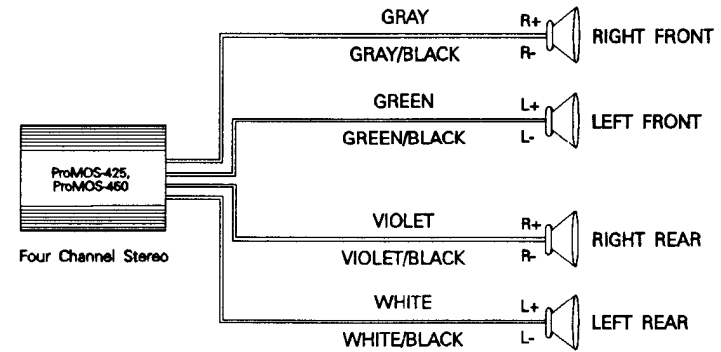

## TROUBLESHOOTING

If for some reason your system fails to operate properly, please refer to this guide. If you are unable to resolve the problem, consult your dealer or call Precision Power at 1-800-62-POWER for further assistance.

NO SOUND	Is the power LED illuminated?	Check fuses in power wire. Be sure Turn-On lead is connected. Check signal leads. Check gain control. Check source unit's volume level. Clean contacts on fuse holder.
NO SOUND IN ONE CHANNEL	Check Speaker Leads.	Inspect for short circuit or open connection.
	Check Audio Leads.	Reverse Left and Right cables to determine if it is occurring before the amp.
	Check Mono Bridge and Bi Amp Crossover Switches on other devices prior to the amplifier.	Depress switches to ensure proper position with respect to the installation.
	If problem is with amplifier...	Have your dealer inspect the unit.
AMP TURNING OFF AT LOW VOLUME LEVELS	Check speakers for damage or short.	Have your dealer inspect the unit.
AMP TURNING OFF AT MEDIUM OR HIGH VOLUME LEVELS	Check speaker connections.	Be sure proper speaker load impedance recommendations are observed. (If you use an ohmmeter to check speaker resistance, please remember that DC resistance and AC impedance may not be the same. However, DC resistance is a good reference for lowest impedance potential).

## THANK YOU

Thank you again for choosing Precision Power's ProMOS-425 and/or ProMOS-450 to enhance your system. Your complete satisfaction is important to us. If you have any comments please feel free to write us.

To update your system with our state-of-the-art equipment we invite you to try our other products. Please consult your PPI dealer for further information.

**Precision Power is the competitive edge**

## LIMITED WARRANTY

This warranty gives you specific legal rights, and you may also have other rights which vary from state to state. Precision Power, Inc. (PPI) warrants its amplifiers and accessories to be free from defects in materials and workmanship under normal use and service for a period of two years from the date of original purchase. The extent and conditions of PPI's Limited Warranty are as follows:

1. PPI warrants that it will either repair or replace at no charge any unit which PPI's examination discloses to be defective and under warranty, provided the defect occurs within two years from the date of purchase, and the product is returned immediately to PPI.
2. The date of purchase of a PPI Amplifier and/or Accessory must be established by an original sales receipt which must accompany the article being returned for warranty work.
3. The provisions of this warranty shall not apply to any PPI unit used for a purpose for which it is not designed, which has been repaired or altered in any way, or which has been connected, installed, or adjusted other than in accordance with the instructions furnished in PPI's owner's manual. Nor shall this warranty apply to any part which has been subject to misuse, neglect, or accident.
4. PPI does not authorize any other person to assume any other liability in connection with its products. THIS WARRANTY IS THE ONLY EXPRESS WARRANTY MADE BY PPI APPLICABLE TO ITS PRODUCTS. ANY IMPLIED WARRANTY OF MERCHANTABILITY OR FITNESS FOR A PARTICULAR PURPOSE APPLICABLE TO PPI'S AMPLIFIERS AND/OR ACCESSORIES IS LIMITED IN DURATION TO THE DURATION OF THIS LIMITED WARRANTY. PPI SHALL NOT BE LIABLE FOR THE INCIDENTAL, CONSEQUENTIAL, OR COMMERCIAL DAMAGES RESULTING FROM THE BREACH OF THIS WRITTEN WARRANTY. Some states or provinces do not allow the exclusion or limitation of incidental or consequential damages or limitations on how long an implied warranty lasts; so the above limitations or exclusions may not apply to you.
5. Your unit will be serviced on an in-warranty basis within the warranty period for the correction of warranted defects. Do not return the article to your dealer. Return the article including your name, telephone number, and return address with the description of the problem to:

Precision Power  
Warranty Department  
4829 S. 38th Street  
Phoenix, AZ 85040

TO RETURN ARTICLES OUT OF WARRANTY. Return the article, postage prepaid, in the original protective carton. Include in the package a description of the problem and, if desired, a request for an estimate of repair costs. Unless a request for an estimate is included, the unit will be repaired as necessary. Fifty dollars (\$50.00) labor, plus parts will be charged for all product repairs. The repaired unit will be returned to the customer with an itemized statement, C.O.D.



## NOTES

