

Orion Accessories

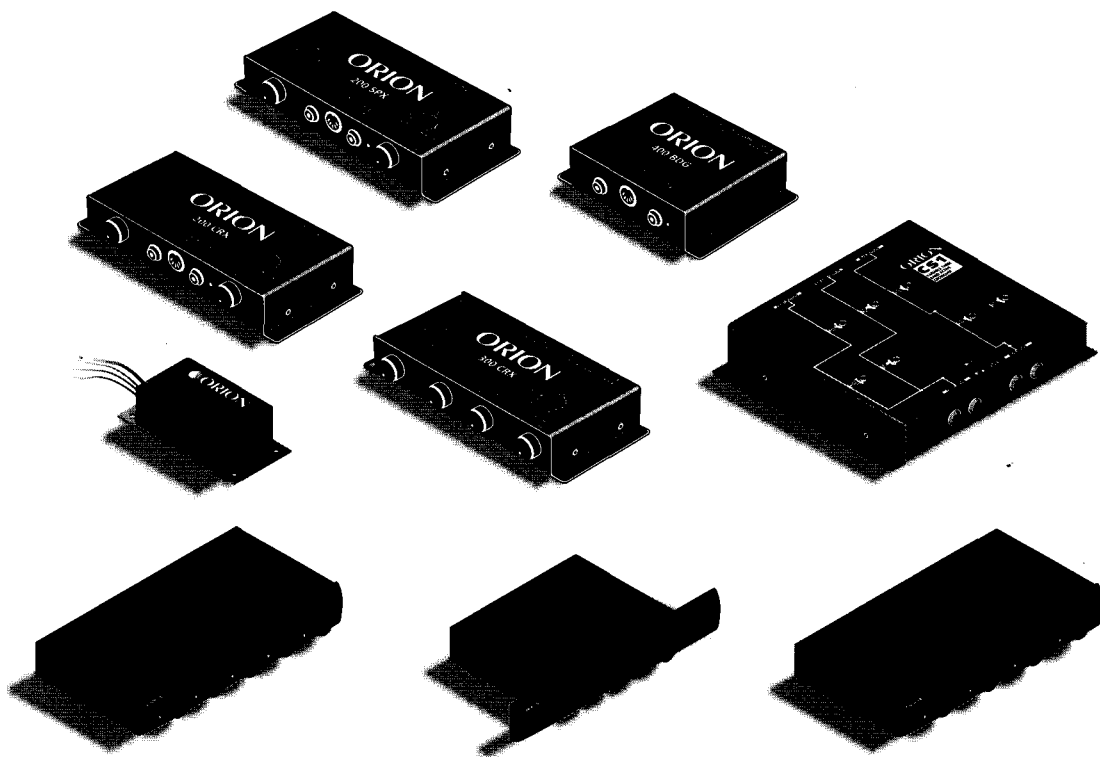

 **ORION™**

CONTENTS

Introduction	1
Descriptions	2
System Uses	10
Installation	11
System Diagrams.....	13
System Adjustments	22
Troubleshooting Guide	23
Notes	24
Warranty Information.....	26



DESIGN

All Orion amplifiers and accessories are designed on our sophisticated CAD system, utilizing the latest available technology.

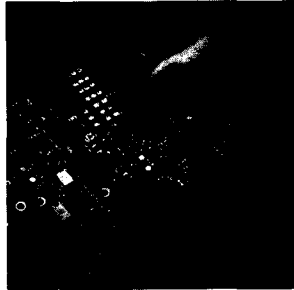

PRODUCTION

All Orion accessories are Made In The USA, with high-quality double-sided PC boards containing superior-grade components.

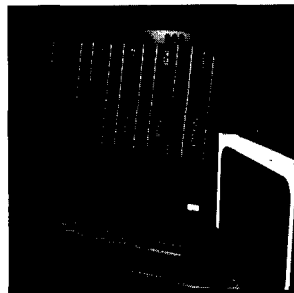

PRODUCT USE

Orion accessories set new standards for performance and reliability.



INTRODUCTION

Orion Accessories are designed to be the latest in state-of-the-art pre-amplifiers and active crossovers. Orion's philosophy states that only the highest quality signal processors should be utilized in any system. Pre-amplifiers by Orion amplify the signal given to them into a stronger, un-colored signal that will bring any amplifier to life! Active crossovers by Orion are designed to not color the sound, and yet give the user a wide variety of adjustments to tailor the sound to their liking. You can be assured that Orion signal processors set the standards for performance, craftsmanship, and reliability.

In addition, all of our signal processors are made in the USA with high-quality, double-sided printed circuit boards, containing superior-grade components. Be assured that before you bought this superbly-built accessory, it was thoroughly tested for the most demanding of situations. This piece of equipment has passed a five-step quality control inspection, if it had failed it would have never been put in the box!

DESCRIPTIONS

100 PPS

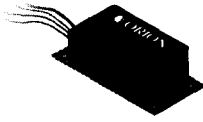

The 100 PPS is a power supply unit which supplies power to the 200 and 300 CRX and 300 PRQ when using amplifiers that are not equipped with phantom power

NOTE: DIN and RCA are in parallel. DIN goes to unit to be powered.



200 CRX

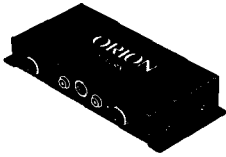

The 200 CRX is a two-way, fully variable active crossover. This unit will accept either DIN inputs from another Orion accessory or RCA inputs from anything with RCA outputs. The outputs of the 200 CRX are both configured as DIN outputs, for use with Orion amplifiers or other Orion accessories.

NOTE: This unit is powered by phantom power, at least one Orion amplifier has to be plugged into one of the outputs.

OUTPUT PLATE



INPUT PLATE

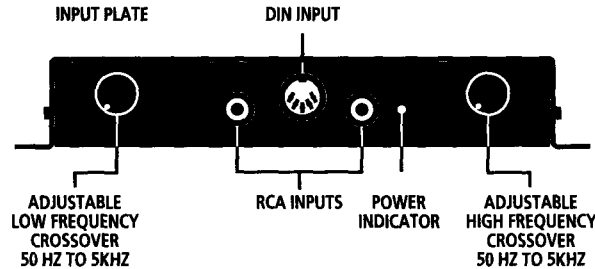

200 SPX



The 200 SPX is a two-way, fully variable active crossover. This unit will accept either DIN inputs from another Orion accessory or RCA inputs from anything with RCA outputs. The outputs are configured as DIN, but do not have to be used with an Orion amplifier. DIN to RCA adapters can be used, so that this accessory can be plugged in to any kind of product. This unit can be powered either by 12 volts, or by phantom power, making it usable with Cobalt series or GT series of amplifiers. There are power, ground, and remote connections that can be used in this configuration.

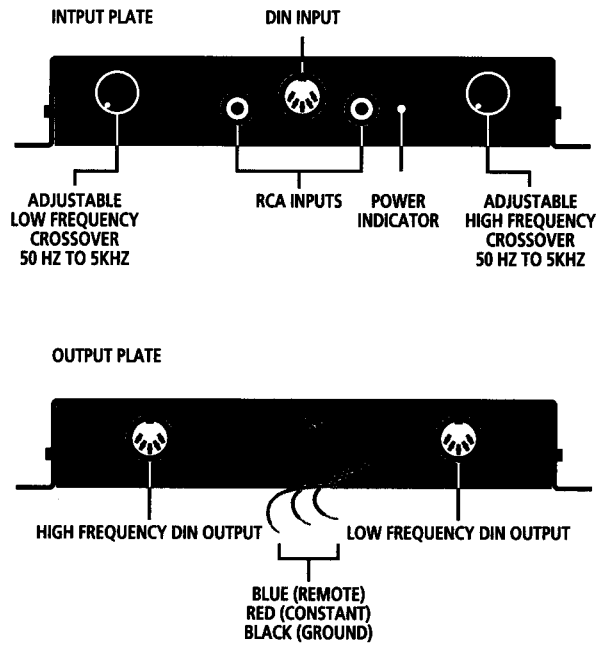

CS1

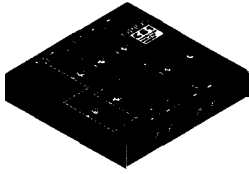

The CS1 is an extremely flexible two or three way active crossover. This unit is powered by 12 volts, making it usable with any amplifier.

The front RCA inputs can be used in either two-way with a fader or three-way without a fader systems.

The 3-way switch allows you to use the unit as a 3 way crossover (this eliminates fader capability). The Mix Switch should also be pushed in when using the CS1 this way.

The rear RCA Inputs are used as rear input in 2-way systems with fader. These can also substitute for front RCA's in a 3-way system.

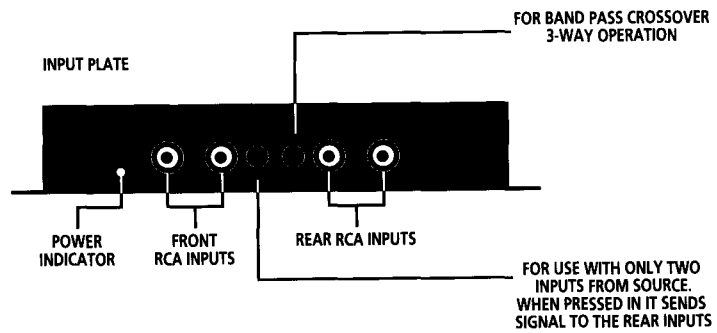
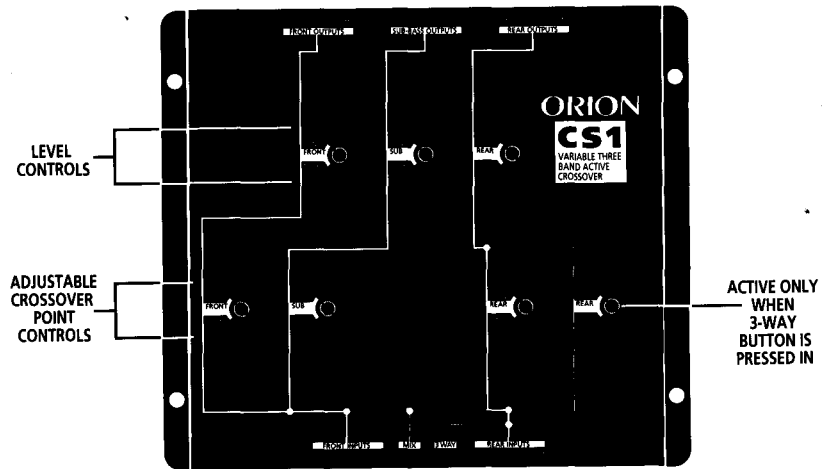
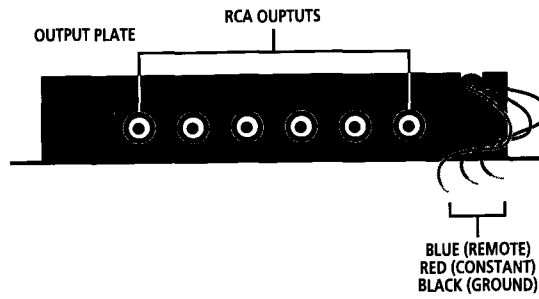

300 CRX



The 300 CRX is a three-way, fully variable active crossover. This unit will accept either DIN inputs from another Orion accessory or RCA inputs from anything with RCA outputs. The outputs of the 300 CRX are all configured as DIN outputs, for use with Orion amplifiers or other Orion accessories.

NOTE: This unit is powered by phantom power, at least one Orion amplifier has to be plugged into one of the DIN outputs!

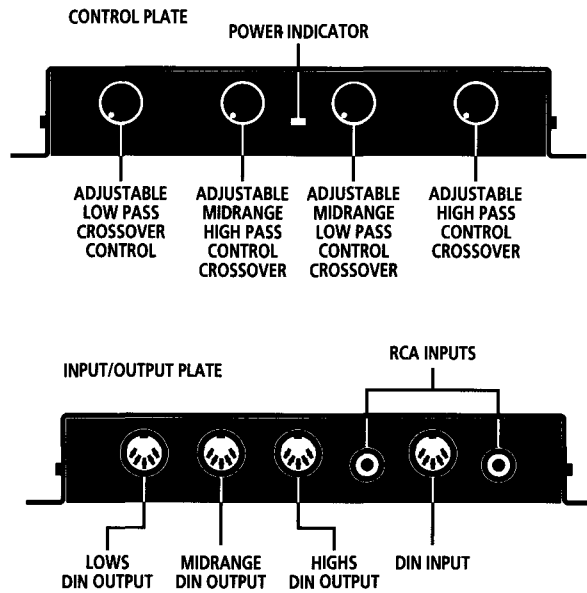

300 PRQ



The 300 PRQ is a 1/2 DIN height preamplifier/ three band equalizer that runs on phantom power. It has RCA inputs and DIN outputs. This unit has to be used with an Orion amplifier with DIN inputs.

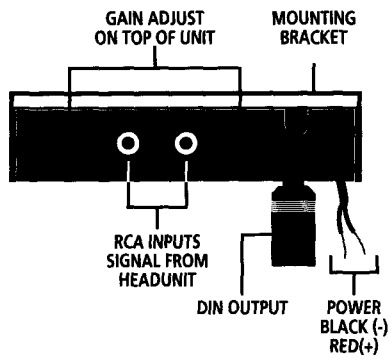
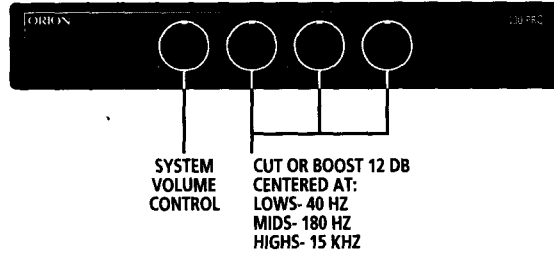

300 PHD

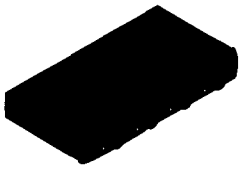

The 300 PHD is a 1/2 DIN height preamplifier/ three band para-graphic equalizer. It has RCA inputs and DIN outputs. This unit can power up with either 12 volts or by phantom power.

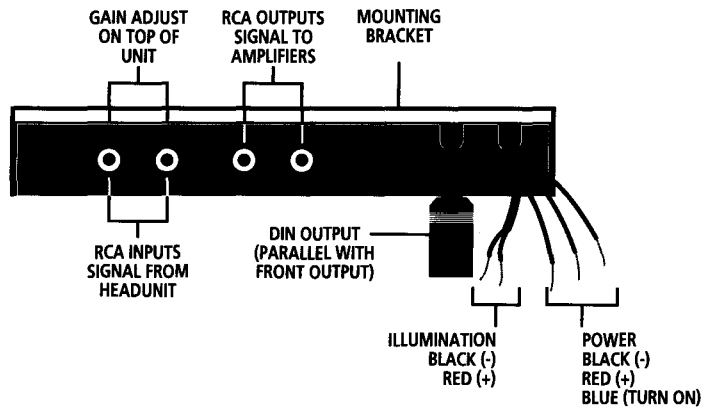
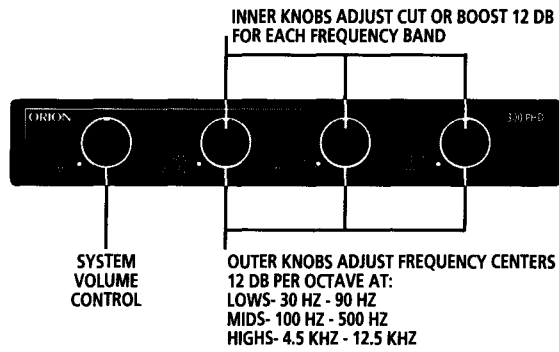

300 PSW



The 300 PSW is a 1/2 DIN height preamplifier/ three band para-graphic equalizer with a fader control and a sub-woofer output. It has RCA inputs and can run off of phantom power or 12 volts, outputs are RCA connections. The sub-woofer output has level and frequency adjustments.

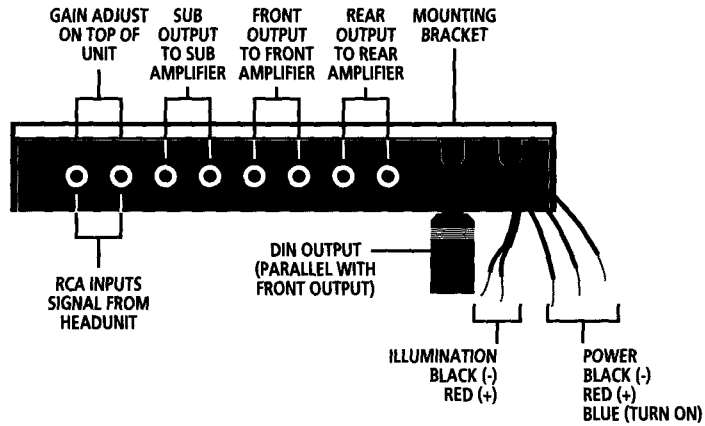
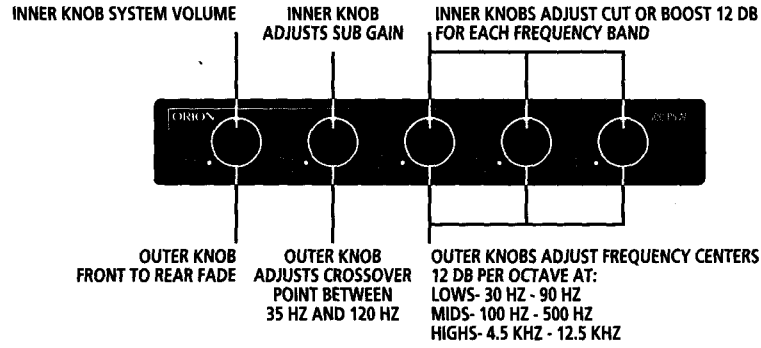

400 BDG



The 400 BDG is a bridging adapter for GX amplifiers only. All other Orion amplifiers have these capabilities built in.

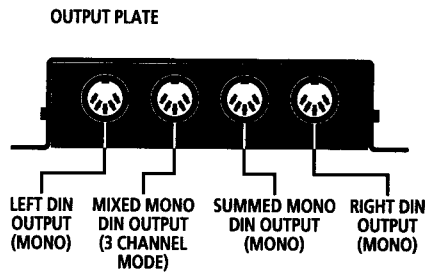
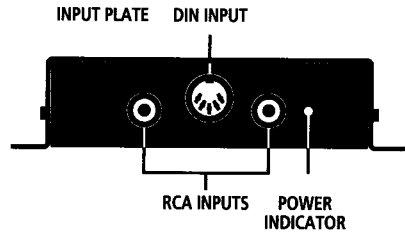

SYSTEM USES

Before starting the installation, you need to consider the type of system that you are looking for. Obviously the electronic crossovers are for multi-amp systems, however, a preamplifier can add spark to any system.

BASIC SYSTEM

Any basic system can use a preamplifier. The 300 PRQ is a perfect entry-level preamplifier. It's three bands of equalization are specifically designed to take care of the three biggest problem areas of most automobiles. The first band is 40 hertz, this is critical due to the lack of bass in most automobiles. 180 hertz is the second band, this is due to the mid-bass bump associated with the width of the car. The third band of equalization is 15,000 hertz, this is because high sounds are often absorbed by fabric interior in the car (all Orion equalizers are based on these frequencies). The preamplifier section of the 300 PRQ is designed to strengthen even the whimpiest of signals. This is especially helpful in lowering the noise floor and bringing the amplifier alive.

If more flexibility is required, the 300 PHD is a good choice because each frequency equalized is selectable. The frequencies are still based on the three bands mentioned above, but now you can fine tune the frequencies to make an exact match to your particular car.

More flexibility is the key to the 300 PSW. The 300 PSW is a preamplifier/equalizer like the 300 PHD, but with more features. The 300 PSW features a fader and an active sub-woofer crossover with variable frequency and level. The four main channels are full range, making this a preamplifier you can use as you expand your system.

MULTI-AMPLIFIER SYSTEMS

In Multi-amplifier systems, the most common crossovers are active crossovers. The 200 CRX/SPX are two great choices in an entry-level multi-amp or multi-channel system. The 200 CRX/SPX both feature completely variable roll-in and roll off frequencies, for overlapping or creating a gap in the mid-bass frequencies.

As your system gets more complex, the 300 CRX is an excellent choice. The 300 features three outputs, infinitely variable frequency adjust, and the ability to overlap and create gaps like the 200 series.

The most flexible crossover however, is the CS1. It can operate like a 200 series, but with a fader. It also operates like a 300 CRX, making it very flexible as you expand your system.

All Orion crossovers can be ganged together to make even more crossover points. For example: a 200 CRX and a 300 CRX can be combined to make a four way crossover.



INSTALLATION

This section details the mechanical and electrical procedures necessary to install Orion accessories.

GENERAL PRECAUTIONS

Preamplifiers

Choose a location in the dash or panel that has plenty of room behind it for your wires, connections, and mounting.

! WARNING!!: THIS CAN BE TRICKY AND IN SOME CASES DANGEROUS, IF YOU ARE NOT SURE, CONTACT AN INSTALLATION SPECIALIST!

Make sure that you can make adjustments to the gain controls easily in this location.

! WARNING!!: BEFORE MAKING ANY TYPE OF HOLE, BE SURE TO CHECK ON WHAT IS BEHIND THE PANEL THAT YOU ARE CUTTING OR DRILLING INTO!

Crossovers

Choose a location accessible for adjustments and cable connections. An ideal location is on the amp rack or near the amplifier(s).

MECHANICAL INSTALLATION

1. Select a mounting location. Make sure that you follow the precautions listed above.
2. Position the unit and use a felt-tip pen to mark the mounting hole(s).
3. Cut out the mounting hole (preamps) or drill pilot holes for the mounting screws (crossovers).
4. Mount the unit in the desired location.

ELECTRICAL INSTALLATION

! IMPROPER WIRING CONNECTIONS CAN SERIOUSLY DAMAGE THE UNIT YOU ARE INSTALLING AND PERHAPS YOUR ELECTRICAL SYSTEM OR OTHER ELECTRICAL COMPONENTS. BE SURE TO FOLLOW WIRING DIRECTIONS IN THIS MANUAL, IF YOU ARE NOT SURE OF SOMETHING, CONTACT AN INSTALLATION PROFESSIONAL.

- Make sure everything in your system is off. If you are not using phantom power, disconnect the lead at the positive (+) battery post.
- If you are using phantom power, just plug in the appropriate amplifiers and accessories with the DIN cables. If you are using 12 volts you will need to ground each accessory and run a turn-on and power lead to each one. The power should come from the vehicle's battery.

! WARNING!!: DO NOT GET POWER FROM THE FUSE-BOX, THIS CAN CAUSE SEVERE NOISE!

The turn-on lead (blue wire) should be attached to the power accessory lead coming out of the head-unit.

NOTE: In some cases the head-unit may not be able to turn-on all of the amplifiers and accessories in the system, a bosch relay can be used (see diagram).

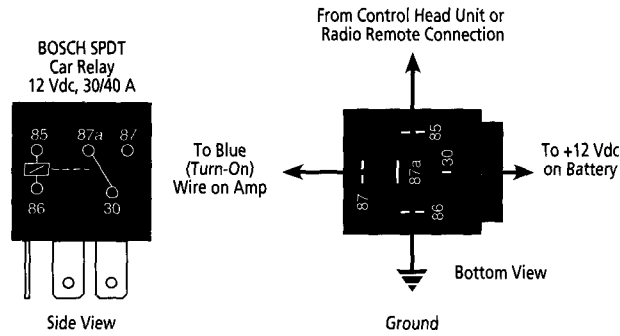

- When replacing fuses, make sure that the fuse used is the identical value to the one replaced.
- When running both power and signal wires, keep them apart from each other. Electro-magnetic interference can occur if the power wires are too close to the signal wires.

SYSTEM DIAGRAMS

The following diagrams represent a few of the possible combinations of Orion components that can be used to enhance your current audio system or to create a new one.



Diagram 1: The 100 PPS phantom power supply module is used in cases where there is not phantom power to run an accessory that utilizes phantom power. For an example; if a COBALT 260 amplifier is being used with a 300 PRQ, the 300 PRQ needs to attain it's power

from the phantom power supply. The phantom power supply delivers the plus and minus 15 Volts that the 300 PRQ needs to power up. Other accessories that need phantom power include; the 200 CRX and the 300 CRX. All other accessories have a built-in phantom power supplies. NOTE: If the amplifier has a DIN input, the DIN cable will supply the necessary power for the accessories that need the phantom power supply.

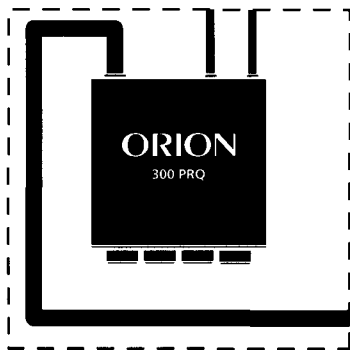
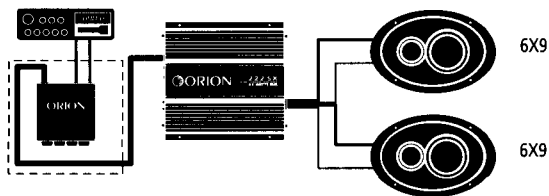

Diagram 2: A preamp is a good addition to even the simplest of systems. In this system, a 300 PRQ is being used. In systems using amplifiers that do not have DIN inputs, a 300 PHD can be used.

Diagram 3: This is a simple system using a 300 PSW. The satellite speakers are full-range, operating off of a four-channel amplifier. The sub woofer amplifier is connected to the built-in sub woofer crossover.

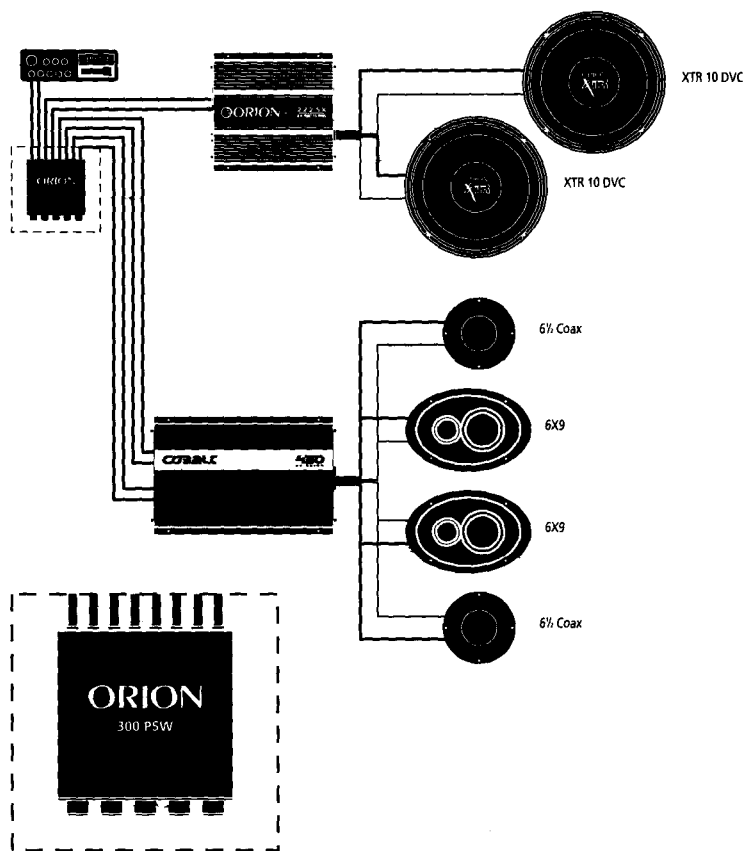
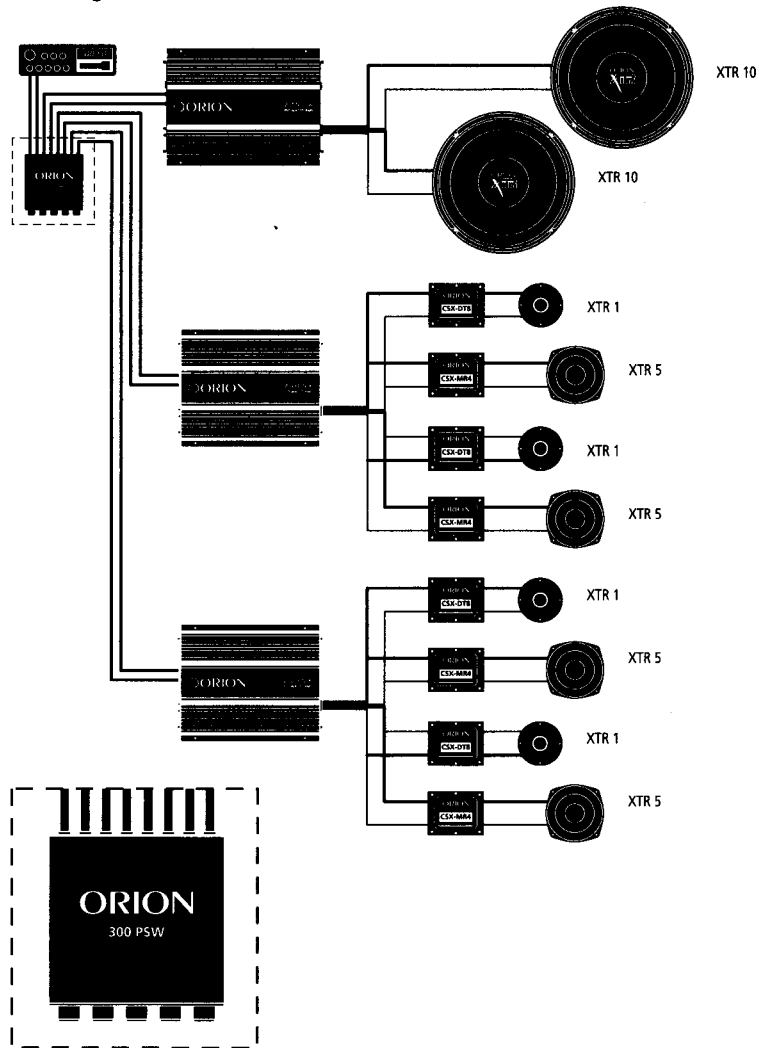

Diagram 4: This is a more complex system using the 300 PSW. In this case the satellite speakers are XTR separates with their appropriate crossover modules. Each set of speakers have their own amplifier, including the subs.



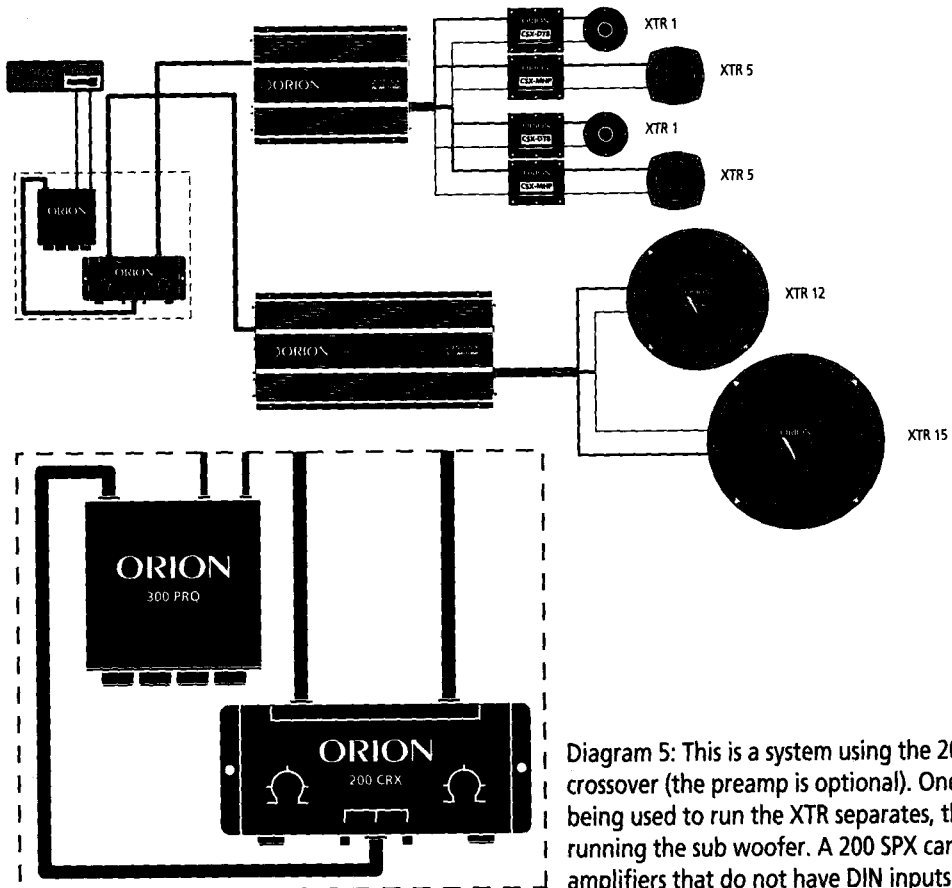

Diagram 5: This is a system using the 200 CRX crossover (the preamp is optional). One amplifier is being used to run the XTR separates, the other is running the sub woofer. A 200 SPX can be used with amplifiers that do not have DIN inputs.

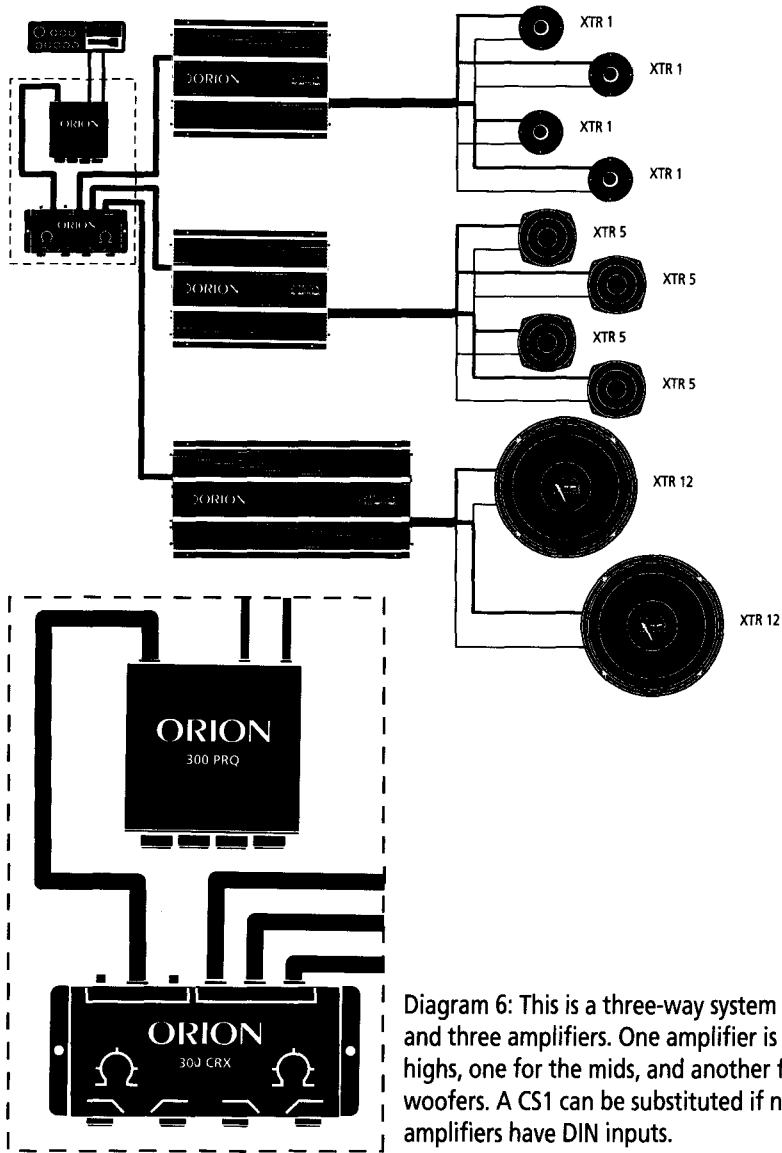

Diagram 6: This is a three-way system using a 300 CRX and three amplifiers. One amplifier is running the highs, one for the mids, and another for the sub woofers. A CS1 can be substituted if none of the amplifiers have DIN inputs.

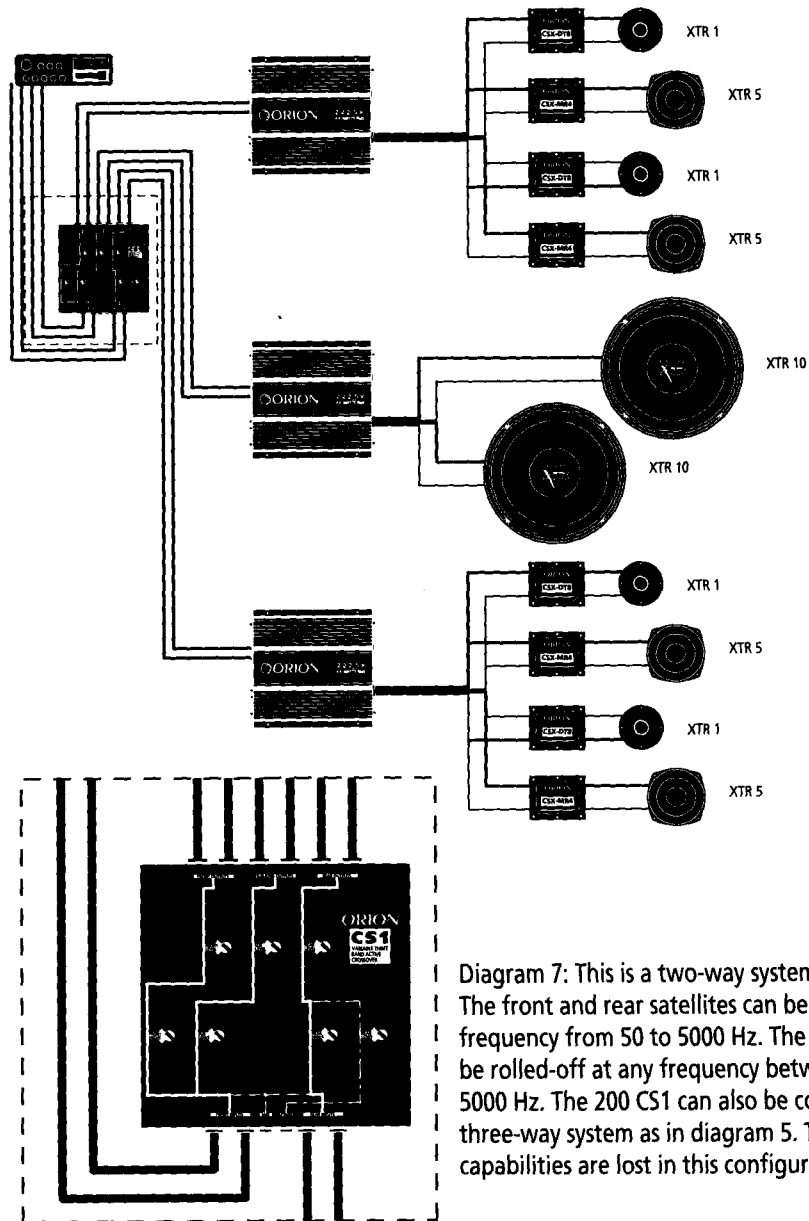
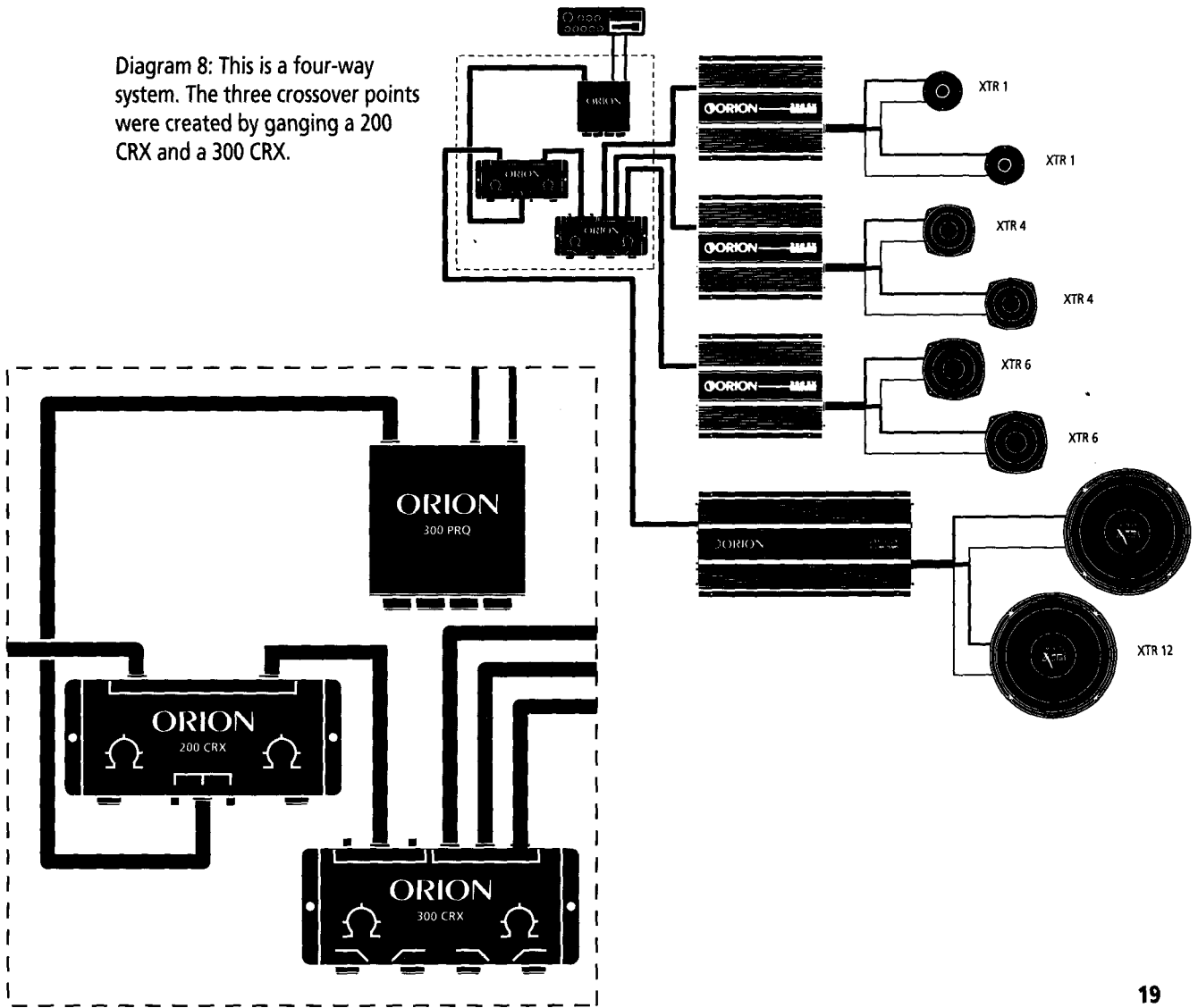

Diagram 7: This is a two-way system with a fader. The front and rear satellites can be rolled-in at any frequency from 50 to 5000 Hz. The sub woofer can be rolled-off at any frequency between 50 and 5000 Hz. The 200 CS1 can also be configured for a three-way system as in diagram 5. The fading capabilities are lost in this configuration.

Diagram 8: This is a four-way system. The three crossover points were created by ganging a 200 CRX and a 300 CRX.



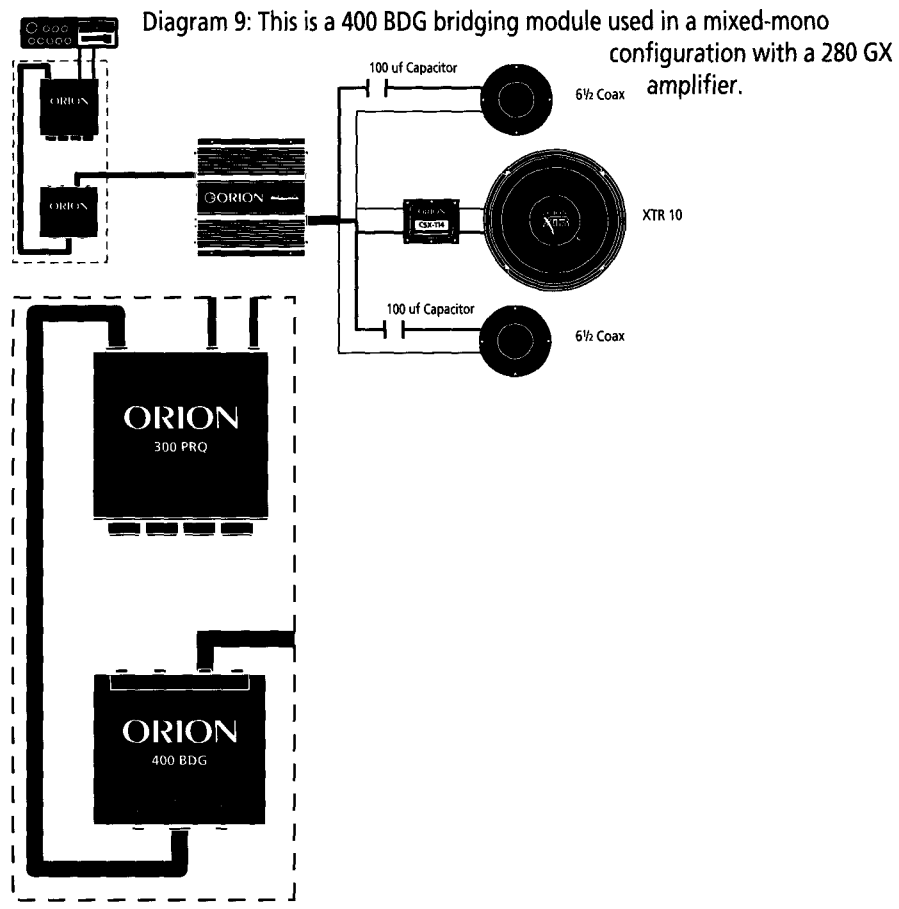
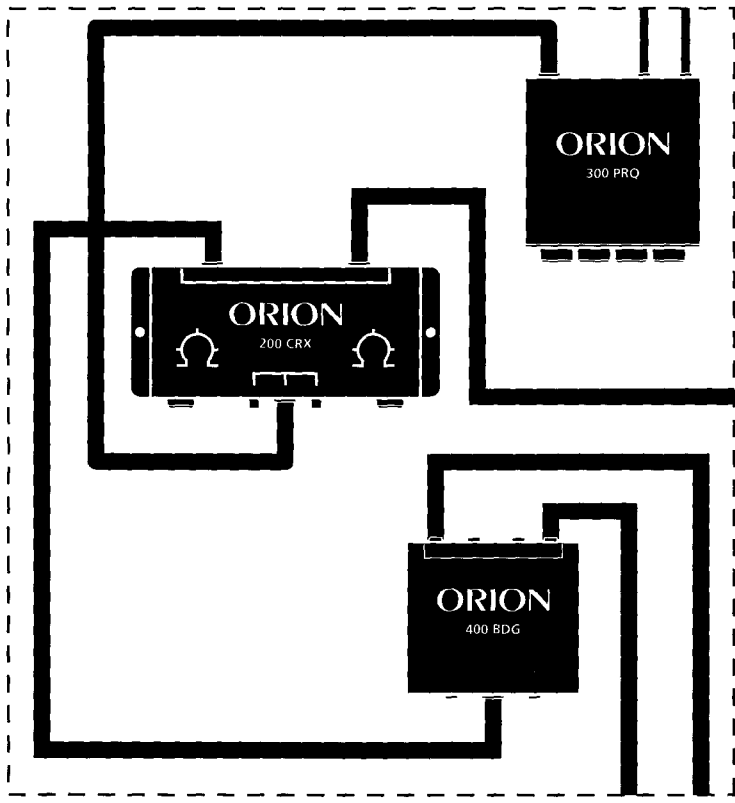
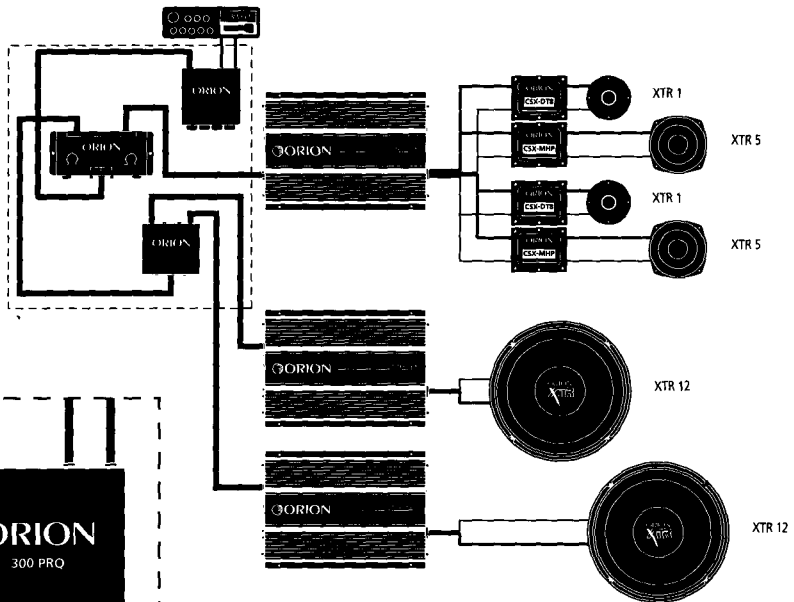

Diagram 10: This is a 400 BDG bridging module used in a mono left and a mono right configuration with two 280 GX amplifiers.





SYSTEM ADJUSTMENTS

Setting the Gains on preamplifiers

1. Turn off the system.
2. Select a good radio station, or use a CD/tape for the source. Make sure that all equalization controls are in the flat position and that the loudness contour is off.
3. Turn the amplifier(s) gain control to the lowest possible position.
4. Turn the volume control on the preamplifier to it's maximum position.
5. Turn the system on and adjust the radio to it's max position or until it distorts.
6. If the system does not reach a level of volume loud enough to create distortion, turn the amplifier gain upward until you hear some, then back the gain back down until the distortion goes away.

NOTE: All Orion SX and HCCA series amplifiers have peak level indicators to aid you in this adjustment.



WARNING!!: HIGH VOLUME LEVELS CAN BE REACHED DURING THIS ADJUSTMENT, APPROPRIATE PROTECTION SHOULD BE WORN.

Setting the Frequency Adjustments on Crossovers

1. Turn off the system.
2. Select a good radio station, or use a CD/tape for the source. Make sure that all equalization controls are set to flat position and that the loudness contour is off.
3. Adjust the woofer roll-off frequency to about 150 hertz.
4. Adjust the mid-range or high-pass (200 series) roll-in to 150 hertz.
5. This step is for three way systems only. Adjust the band-pass roll-off to 3000 hertz, and the high-pass roll-in to 3000 hertz.
6. These should be good starting points. Now turn the system to a moderate listening level and make fine tuning adjustments. Remember that every car is different and each individual's tastes vary, adjust the system to your liking, not to some preconceived notion.
7. After making fine tuning adjustments, go through the "adjusting the gain" steps provided with your amplifier and make sure they are still set satisfactorily.

NOTE: If there is some distortion at moderate to high levels and the gains are set correctly, the crossover point(s) may have to be adjusted.



TROUBLESHOOTING GUIDE

This section provides you with a catalog of amplifier symptoms and their probable causes and solutions. Before you consult this listing, make sure the vehicle's electrical system is working properly by verifying that other electrical items (e.g. headlights, windows, etc.) still function correctly.

SYMPTOM	PROBABLE CAUSE	SOLUTION
No Audio	Low or No Remote Turn-On connections	Check remote turn-on voltage at amp and head unit
	Blown Fuse	Replace with new fast-blow fuse
	Power wires not connected	Check butt splices or solder joints; check Ground and Battery connections
	Blown speakers or not connected	Use VOM or DVM to measure speaker coil impedance; check speaker wiring connections
Distorted Audio	Input Sensitivity not set properly or damaged speaker cones	See Calibrating Input Sensitivity procedure and check each step; inspect each speaker for damage and repair or replace suspected component
Audio lacks	Speakers wired with wrong polarity, causing cancellation of bass frequencies	Check polarity of wires from amplifiers to each speaker as defined by the system design
External fuse blowing	Incorrect wiring or short circuit	Refer to Electrical Installation and check keeps each installation step
Whining noise on audio with engine running	Amplifier or accessory is picking up alternator noise	Install an in-line noise filter on the head unit's power wire; check alternator diodes or voltage regulator for proper operation
Ticking noise on audio with engine running	Amplifier or accessory is picking up radiated spark noise	Check RCA audio cables routes; install an in-line noise filter on the head unit's power wire

NOTES

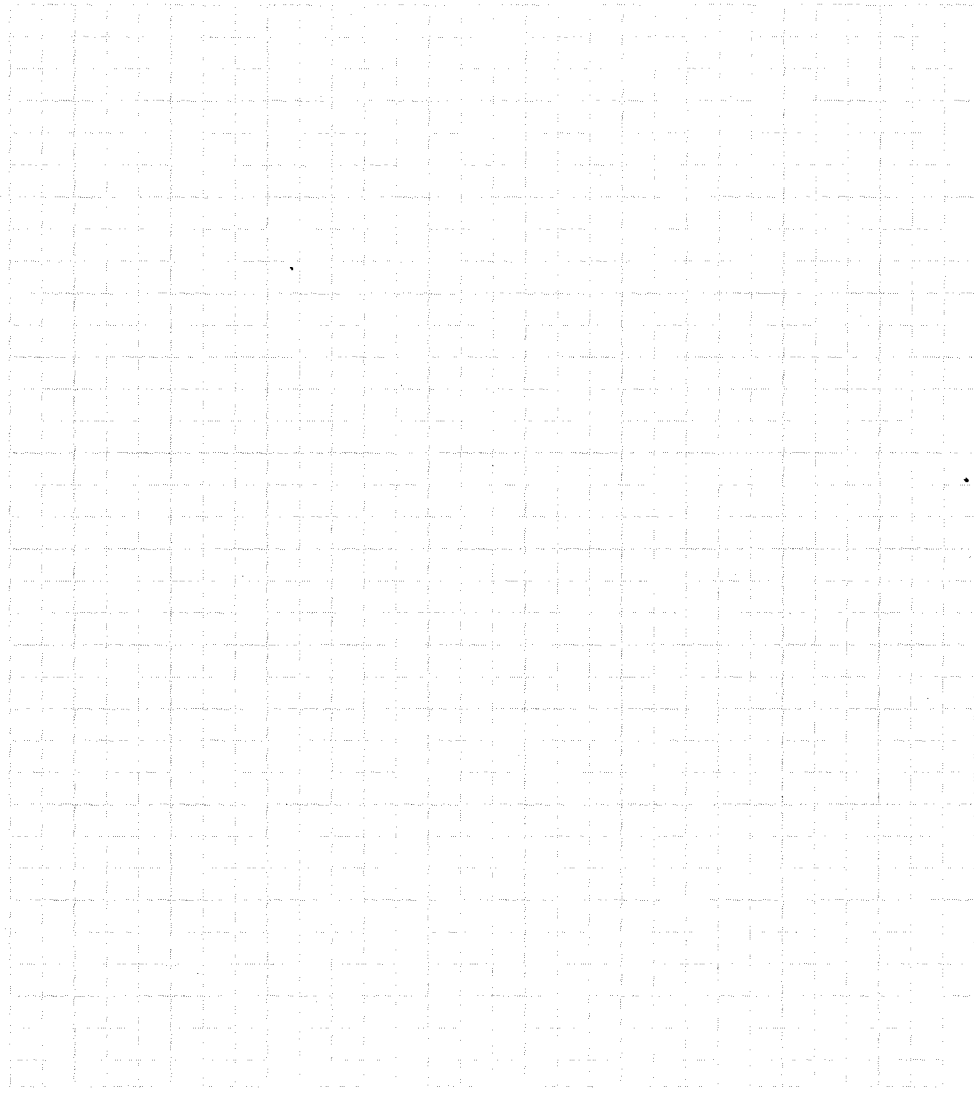

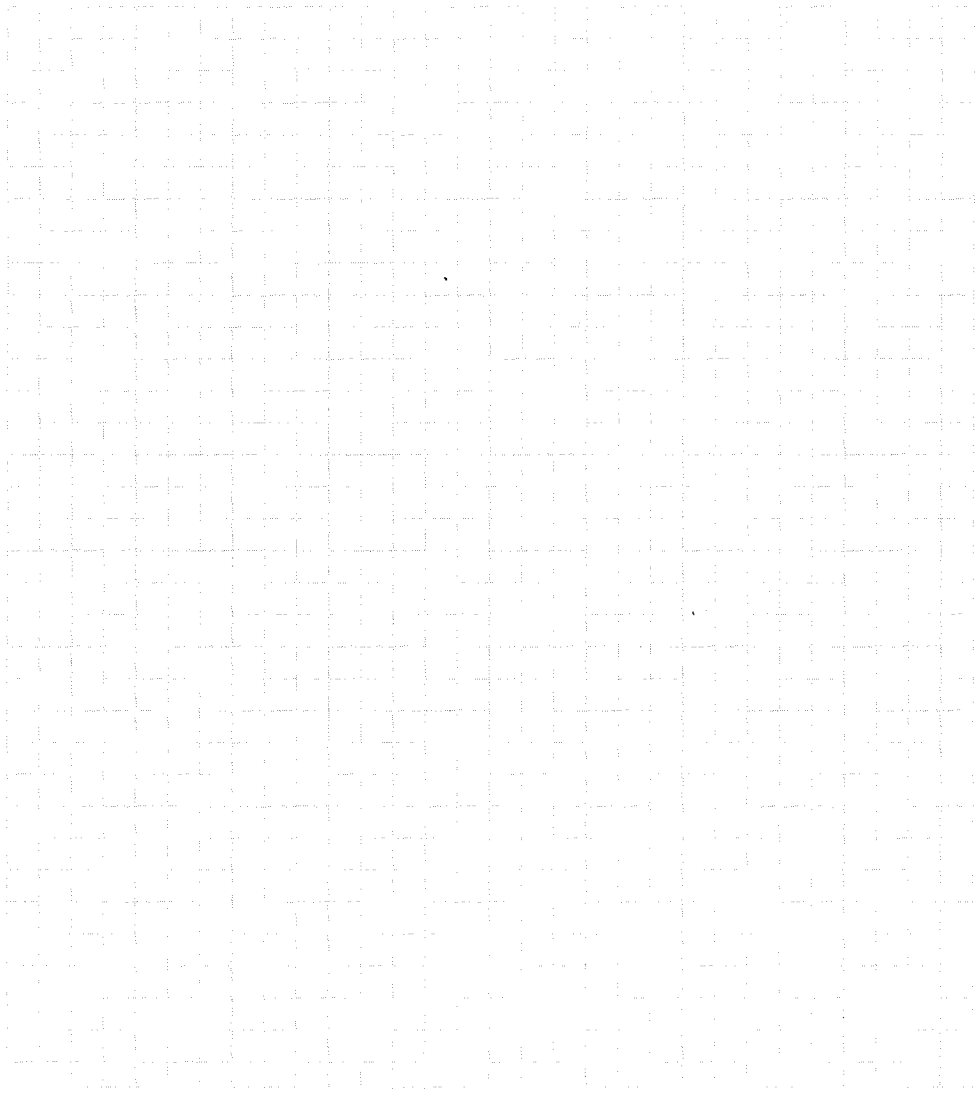

WARRANTY & SERVICE

Orion Industries, Inc., warrants to the original purchaser only that all new Orion products shall be free from defects in workmanship and materials for a period of 90 days from the date of purchase, as shown in the dealer's original Bill of Sale. All Orion products are thoroughly tested by experienced technicians, to insure that they meet or exceed our performance specifications.

Orion agrees that defective products will be repaired or replaced (at our option) at no charge for labor or materials, provided that our inspection discloses that the defective products have not been subjected to misuse, negligence, or accident; damaged by modification, improper installation, or incorrect voltage; altered or repaired by other than Orion factory personnel, had the serial number or any other part altered, defaced or removed; or used in any way that is contrary to Orion's written instructions.

In order to obtain warranty service send the defective product, by prepaid freight, to Orion, together with a copy of the Original Bill of Sale. The product will be repaired or replaced, at our option, and returned freight prepaid, providing the unit is under warranty.

AUTHORIZED DEALER WARRANTY EXTENSION

Orion Industries, Inc. places great importance on the role of authorized dealers. Orion dealers are expertly trained to provide our customers with accurate information regarding our product. Orion will extend the warranty period of any Orion product if it has been purchased by an authorized Orion Dealer. When requesting service, a bill of sale must be presented to verify that the product was purchased from an authorized Orion Dealer. Please call Orion Industries, Inc. if you need to verify your authorized dealer's status. The warranty period for purchases made from an authorized Orion Dealer will be as follows:

Orion amplifiers, crossovers, signal processors	2 years
Orion XTR woofers	Lifetime
Orion Midrange speakers	1 year

EXCLUSIONS

1. The 100 PPS holds a 90 day warranty.



This paper is recycled and is 100% recyclable.

HIGH PERFORMANCE
CAR AUDIO AMPLIFIERS,
SIGNAL PROCESSORS
AND LOUDSPEAKERS.
MADE IN THE USA.



ORION INDUSTRIES, INC. 118 W. JULIE DR., TEMPE, ARIZONA 85283
602.730.8200 FAX 602.831-8101 PN 9000-0077