

Congratulations on your purchase of the 3-Door Programmable Garage Door Receiver with ACG (Anti-CodeGrabbing™). You can use your existing Clifford ACG remote control(s) to individually command up to 3 separate garage door openers and/or electric gate(s) (note: this product will not work with older Clifford remote controls). You can even use the same remote control to command various low-voltage devices in your home (such as a home security system) as well as control Clifford ACG vehicle security system(s) and accessories on your automobile(s).

What is code-grabbing?

Your existing garage door remote control transmits the same digital code every time you press the button. So thieves now use a code-grabber, a device that literally records, from hundreds of feet away, the code sent by your garage door transmitter. When you have left, they just use the code-grabber to retransmit the code and activate your garage door opener.

Thieves have been using this same code-grabbing technology to disarm car alarms. So Clifford Electronics, the world leader in auto security technology, developed Anti-CodeGrabbing: ACG. Clifford's ACG remote controls **NEVER** transmit the same code twice. Each time you use your Clifford ACG remote control, it randomly changes the code.

How to connect the 3-Door Programmable Garage Door Receiver to your garage door opener(s)

1. Unplug the power cord(s) of the garage door opener(s).
2. If the opener uses an **external** receiver module, disconnect its terminals as shown in diagram 1.
3. If the opener uses an internal receiver module, perform the *Detuning the Opener's Receiver* procedure on page 3.
4. Mount the 3-Door Programmable Receiver **above the garage door** as shown in diagram 1.

NOTE: Do not mount the receiver module over or near metal. Doing so will reduce remote control range.

5. **For Garage Door #1:** Connect one of the three supplied brown, twin-lead wires to the two screws under the “I” on the 3-Door Programmable Receiver.

NOTE: Keep all wires away from the garage door and drive mechanism.

6. Attach the other end of the twin-lead wire to the same screws used for the interior push button control, as shown in diagram 1.
7. If you wish to control a second or even a third garage door with the same receiver, repeat steps 5 and 6 for garage door opener #2 and #3 using the two screws noted for opener #2 and #3 on the 3-Door Programmable Receiver.
8. Plug the AC adapter into a wall outlet and plug its connector into the bottom of the 3-Door Programmable Receiver.

NOTE: Keep the cord away from the garage door and drive mechanism.

9. Reconnect the garage door opener’s power cord.
10. Attach the supplied whip antenna to the connector on the 3-Door Programmable Receiver.

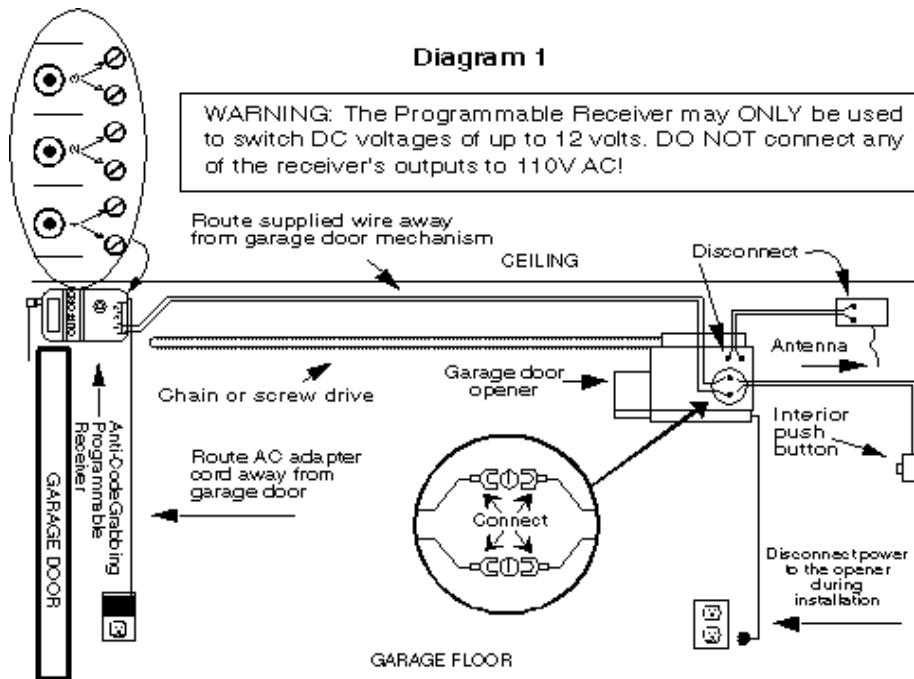

Detuning the electric garage door's existing receiver

Skip this section if your garage door opener has an external receiver or if your garage door opener never had a remote control.

The garage door opener's original receiver must be disconnected or "detuned" to make it impervious to "scanners." (Burglars use scanners to rapidly transmit one garage door remote control code after another, often activating the garage door opener in a matter of seconds. Unless you detune the existing receiver, your garage door opener will still retain the original remote control code and will open the door when a scanner transmits that code.) To detune a garage door receiver, perform the following:

1. Unplug the garage door opener's power cord.
2. There are two types of receivers: external and built-in. If your opener uses an external receiver, you should have already disconnected its terminals as part of the installation procedure (page 1, step 2).
3. If your garage door opener does not have an external receiver, you must detune its built-in receiver. Near the garage door opener's antenna wire, you will find its tuning device(s). You may need to remove the opener's outer housing in order to access the circuit board.
4. Most receivers use "tuning slugs." ***It may be necessary to poke through a decal in order to gain access to the tuning slug holes*** (as illustrated in diagram 2).
 - *On some openers, the tuning slugs may be located on the exposed printed circuit board (diagram 3).*
 - *Use the supplied tool to turn the inner core counterclockwise until it can be removed (diagram 4).*
 - *If the receiver uses a "tuning capacitor," use a screwdriver to turn the screw 1/4-turn in either direction (diagram 5).*
 - *On a Genie "Genius" type opener, peel back the label on the circuit board and rotate the screw a quarter-turn in either direction (diagram 6).*
5. Reconnect power to the garage door opener and activate the *original* remote control. The opener should NOT respond. Repeat steps 1-5 for garage door/gate openers #2 and #3, if applicable.

Diagram 2

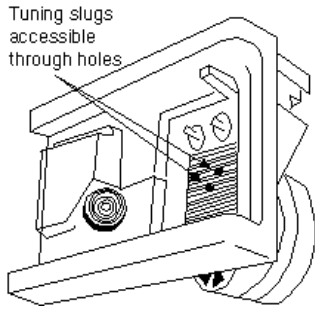

Diagram 3
Circuit Board View

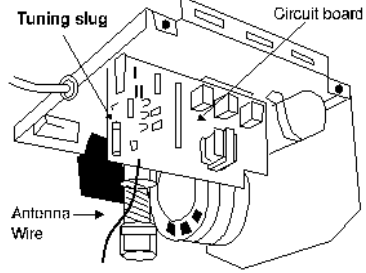

Diagram 4
Adjustment of Tuning Slugs

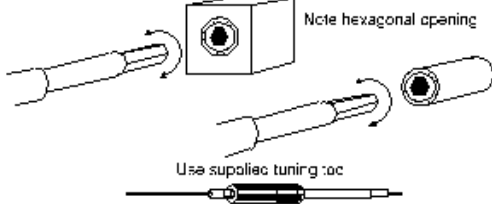

Diagram 5
Tuning Capacitor

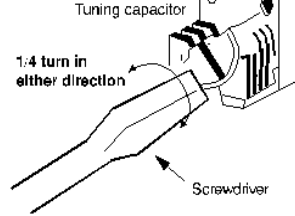
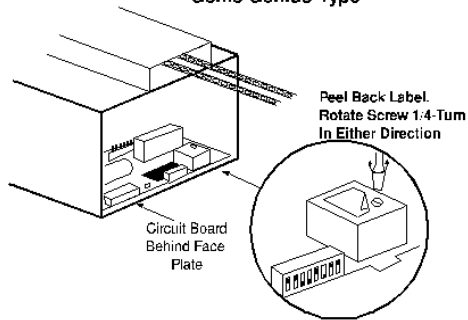
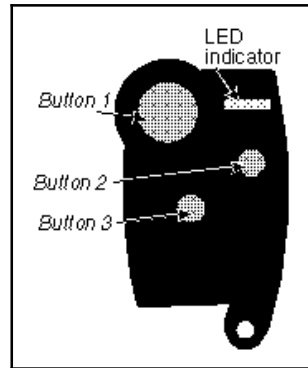

Diagram 6
Genie Genius-Type



How to use your keychain remote control

Clifford Electronics makes two types of Anti-CodeGrabbing remote controls. The 3-channel Clifford remote control illustrated to the right and a 12-channel remote control illustrated below. The 3-button/3-channel remote control can command three different items, while the 4-button/12-channel model can command the Programmable Receiver's three different channels plus up to nine other functions of additional Programmable Receivers and/or Clifford vehicle security systems and accessories on your vehicle(s).



You select and transmit the channels in the following manner:

- ***To transmit either channel 1, 2, 3 or 4:*** Just press either button 1, 2, 3 or 4. For instance, to transmit channel 3, press button 3. While you transmit, the LED indicator will blink once every second: this indicates **level 1**.

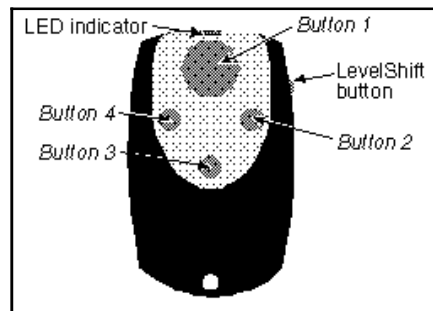

- ***To transmit either channel 5, 6, 7 or 8:*** Press the LevelShift button once. This shifts buttons 1–4 to level 2 (channels 5–8). Then press the desired button *within the next 7 seconds*. For instance, to transmit channel 5, press the LevelShift button once, then press button 1. While you transmit, you'll notice that the LED indicator blinks twice, pauses, blinks twice, etc.: this indicates **level 2**.
- ***To transmit channel 9, 10, 11 or 12:*** Press the LevelShift button twice. This shifts buttons 1–4 to level 3 (channels 9–12). Then press the corresponding button within the next 7 seconds. For instance, to transmit channel 12, press the LevelShift button twice, then press button 4. While you transmit, you'll notice that the LED blinks three times, pauses, blinks three times, etc.: this indicates **level 3**.

NOTE: One second after you stop transmitting level 2 or level 3 (channels 5–12), the remote control automatically returns to level 1 (channels 1–4).

How to program Clifford ACG remote controls into the 3-Door Programmable Garage Door Receiver

Your 3-Door Programmable Receiver can recognize as many as 8 different Clifford remote controls with Anti-CodeGrabbing (ACG). Please note that this product will not work with older Clifford remote controls. ***ACG Remote controls are available from your local Clifford dealer or you may call the Clifford Customer Service Department toll-free at (800) 824-3208.***

To Add a new ACG Remote Control to the Programmable Receiver:

1. To control output 1, tap the blue button on the face of the 3-Door Programmable Receiver until the red LED for output 1 illuminates.
2. Press the Clifford ACG remote control button (or channel) that you want to use to activate garage door opener #1. Release the remote control button when the LED turns off to indicate that the receiver has stored the transmitted channel in its non-volatile memory.
3. To control a second garage door opener, tap the blue button on the 3-Door Programmable Receiver until the indicator light for output 2 illuminates.
4. Transmit the channel you want to use to activate garage door opener #2. Immediately release the button when the Programmable Receiver's red LED turns off. Output 2 is now programmed.
5. To program a third garage door opener, tap the blue button on the 3-Door Programmable Receiver until the indicator light for output 3 illuminates.
6. Transmit the channel you want to use to activate garage door opener #3. Immediately release the button when the Programmable Receiver's red LED turns off. Output 3 is now programmed.

How to delete a lost or stolen remote control

If you wish to delete a lost or stolen remote control, you need to “push” its code out of the receiver's memory. Doing so is simple. Just repeat steps 1-6 above for a total of 8 times with your current remote control. If you are using two remote controls, repeat steps 1-6 four times for each. If using more than two remote controls, program each so that the total adds up to eight.

Using a 3-Door Programmable Garage Door Receiver to control other electronic devices in the home

With the help of an electrician, you can use your 3-Door Programmable Receiver to control a number of low-voltage electronic devices in your home, such as low-power “Malibu-type” exterior lighting systems, home security systems, certain spa heaters, and other non-AC, switch-controlled items. To control these devices, the 3-Door Programmable Receiver’s outputs can be set to provide a latched ground signal instead of a pulse.

How to switch the receiver output(s) from pulsed to latched

1. Repeatedly tap the button on the face of the Programmable Receiver until the LED illuminates next to the output number that you wish to be with a latched output.
2. ***Press and hold for at least 5 seconds*** the button on the Clifford remote control. The LED will blink twice, then turn off to indicate that output will provide a latched ground signal.
3. Repeat steps 1 and 2 for any other outputs that will have a latched output.

How to switch an output from latched to pulsed:

1. Repeatedly tap the button on the face of the Programmable Receiver until the LED illuminates next to the output you wish to use.
2. Press the button on the Clifford remote control. Release it as soon as the LED turns off.

Remote controls and remote control batteries are available from your local Authorized Clifford Dealer or you may call the Clifford Customer Service Department toll-free at (800) 824-3208.

CLIFFORD
World-Class Auto Security™