

P640
amplifier / crossover
instruction manual

a/d/s/

Analog and Digital Systems
One Progress Way
Wilmington, MA 01887
USA

table of contents

introduction	1
about this manual	1
features of your PowerPlate™	2
warning and tips	3
system planning	4
system configurations	6
mounting locations	11
installation	12
controls and connections	13
multi-cross™ crossover and configurations	16
tuning	17
troubleshooting	19
specifications	21
warranty information	

introduction

Thanks for choosing this a/d/s/ PowerPlate™ amplifier. Your new PowerPlate™ is the latest in a line of innovative car audio firsts which began back in 1974 when a/d/s/ introduced the first car system to use a switch-mode power supply; the technology which makes today's high power car amplifiers possible. Your new PowerPlate™ incorporates technology which is as advanced today as that early a/d/s/ 2001 system was in 1974. From the flexible built-in crossover functions to the Transient Perfect™ power supply and sophisticated circuit design by renowned audiophile engineer Ed Meitner, each part of your new a/d/s/ PowerPlate™ was specifically selected to deliver the most from all types of music. Whether asked to deliver the power of the most outrageous Synth-Bass or the subtle nuance of an acoustic guitar, the technology of your a/d/s/ PowerPlate™ is focused towards one goal - to deliver the sound as it should be.

about this manual

To get the most from your a/d/s/ PowerPlate™, we recommend that you have the installation performed by your qualified authorized a/d/s/ dealer. If this unit is installed by your dealer, we will extend the warranty to three-years instead of the standard one-year. However, if you feel that you have the necessary skills and prefer to perform the installation yourself, this manual will guide you through the process of installation and set-up. Please read through it completely before beginning the installation so that you may familiarize yourself with the total procedure before you begin. If there is anything that you do not fully understand, please consult with your a/d/s/ dealer before attempting the installation.

keep listening, but be safe!

Sustained listening to loud music over 100dB has been shown to cause permanent hearing damage. Systems using a/d/s/ components are capable of achieving volume levels which substantially exceed this level. When operating your system for sustained periods at high volume, be sure to use hearing protection to prevent long-term exposure. We want you to be able to enjoy the music for many more years.

features of your PowerPlate™

Transient Perfect™ MOSFET Power Supply - The heart of the P-series, this supply frees the PowerPlate™ from the constraints of common pwm (pulse width modulated) supplies. The advantages are: extremely fast overload recovery time, low output impedance for superior damping, and stability during voltage fluctuations for reliable performance in the harsh automotive environment.

Remote Subwoofer Control Capability - Can be used with accessory control AC502 to provide a dashboard mounted subwoofer or rear channel level control.

Detachable Plug in Connectors - High-current speaker and power connectors simplify installation.

Multi-cross™ Variable Built-In Crossovers - High-pass, Low-pass and Band-pass functions are built-in, virtually eliminating the need for external crossover networks in even the most elaborate systems.

PowerPlate™ Design - a/d/s/ original low profile, high efficiency heatsink design keeps size minimum and allows mounting where space is limited.

Wide input sensitivity range - Allows connection to virtually any source unit from Factory OEM radios, through low output preamps.

Simultaneous Stereo + Mono - Each channel pair may be used Stereo, Mono, Bridged or both Stereo + Mono simultaneously. This allows an additional Mono speaker to be used with a stereo pair for center-channel or subwoofer applications from each channel pair.

Same Side Adjustments - The P-series PowerPlate™ makes system adjustment easy by organizing all signal processing controls on one side of the amplifier. This layout allows convenient system adjustment and facilitates a variety of installation possibilities when access to the controls is desired.

warnings and tips

Always disconnect the battery ground wire before doing any work on your vehicle. Reconnect the cable only after the installation is complete and the wiring has been checked to make sure that there are no problems. If your radio features a code type security system be sure you know the code before disconnecting the battery!

Your a/d/s/ PowerPlate™ should be installed in 12V negative ground vehicles only. Connection to other types of electrical systems may cause damage to the vehicle or the amplifier.

Wear Eye and Ear protection when using power tools.

Before cutting or drilling carefully inspect the area carefully to make sure there is no electrical wiring, fuel lines or brake lines which could be damaged. Sometimes these components may be hidden between double-walled panels, so be very careful.

Do not bypass or modify the fuses, or replace with one of a higher rating. The fuse should not fail under normal operation. Repeated blowing indicates a problem with the amplifier or improper installation.

An additional power supply line fuse (not supplied) must be installed on the 12V supply line and located as close as possible to the battery in order to protect the wire in the event of a short circuit.

Never operate the vehicle without the PowerPlate™ firmly mounted. An unmounted amplifier can be a dangerous missile in an accident or abrupt stop.

The PowerPlate™ should not be mounted where it will be exposed to moisture or extreme heat.

The PowerPlate™ should be mounted in such a way that air can circulate around the fins. The most efficient cooling is with the PowerPlate™ mounted vertically with the fins also vertical, or with the PowerPlate™ mounted flat to the floor. Do not mount the PowerPlate™ horizontally with the fins pointing downwards.

Make sure the system is turned off when making or breaking any connections.

Do not use your PowerPlate™ with speakers which have either terminal connected to the speaker frame or to the vehicle chassis.

system planning

Proper system planning is the best way to maximize its performance. By planning your installation carefully you can avoid situations where the performance or the reliability of your system is compromised. Your authorized a/d/s/ dealer has been trained to know how to maximize your system's sonic potential. They are a valuable resource in helping you with your system design and installation.

speaker requirements

Each channel of your PowerPlate™ can easily drive 2-Ohm speaker loads when used in the stereo mode. When a channel-pair is bridged, the recommended minimum load impedance is 3-Ohms for subwoofer use, and 4-Ohms for full-range operation. Although operation with lower impedances is not likely to cause immediate damage to the internal circuitry, the unit will most likely overheat, causing the thermal protection circuitry to activate to shut down the amplifier. When the chassis cools down, normal operation will resume. Continuing to operate the amplifier under these conditions is not recommended and will reduce its life expectancy.

Most speakers designed for car audio operation are 4-Ohm impedance. Connecting two such speakers in parallel will result in a 2-Ohm impedance load as seen by the amplifier. Some a/d/s/ subwoofer models feature a dual 6-Ohm voice coil design. Connecting these voice coils in parallel will result in a 3-Ohm nominal impedance which is safe to use with either stereo or bridged channels of your PowerPlate™.

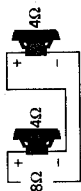

Series wiring

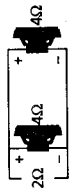

Parallel wiring

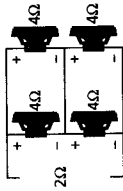

Series / Parallel wiring

signal sources

Due to the wide input level adjustment range, all a/d/s/ PowerPlates can be driven with either a conventional preamplifier drive signal or the amplified signal from a powered source unit. This makes the PowerPlate™ perfect for upgrading an OEM ("Original Equipment Manufacturer") stereo system, while retaining the factory installed radio.

Because of the high impedance of the a/d/s/ input stage, the factory radio drives an easy load and therefore does not produce the distortion levels that it normally would when driving speakers or a Line Output Converter accessory. As a result, you can enjoy high quality sound which is nearly as good as the sound from a high-end aftermarket source unit when using a high quality factory installed radio. The speaker outputs of the factory radio are simply connected to standard RCA type plugs as shown below. From this point on, the signal can be treated exactly as you would a preamp-level signal, except that the input level controls on the PowerPlate™ will be set to a lower than usual level when you make your final adjustments.

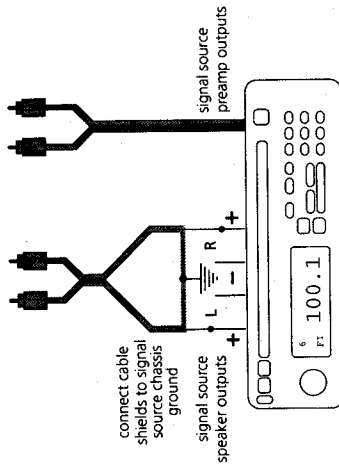
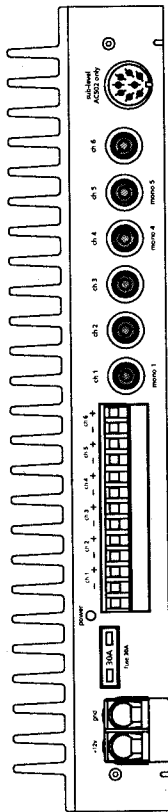

Conventional aftermarket sources may be connected using standard shielded RCA cables from the source units preamp outputs to the PowerPlate™ inputs.

Warning! When using 4 channels of input, be sure to configure the 2ch/4ch input switch to 4ch input. Failure to do so may result in damage to the source unit.

system configurations

All a/d/s/ PowerPlates provide extensive features which make a variety of system configurations possible. It is not feasible to show all the possibilities within a few pages of this manual. There are a few system configurations which are very popular when used alone, or as a "building block" of a larger more elaborate system. Please review the systems 1-6 described below for suggestions on how to configure the most popular combinations. Larger systems may be built from a combination of the simpler systems as shown in system 7.

System 1— The P640 used in 6 channel mode with channels 1 and 2 used for front high-pass speakers, channels 3 and 4 are used for rear high-pass speakers and channels 5 and 6 are used to drive subwoofers. Although shown as a 4 channel input, the source unit can be either 2 or 4 channel depending on the setting of the 2/4 channel switch.

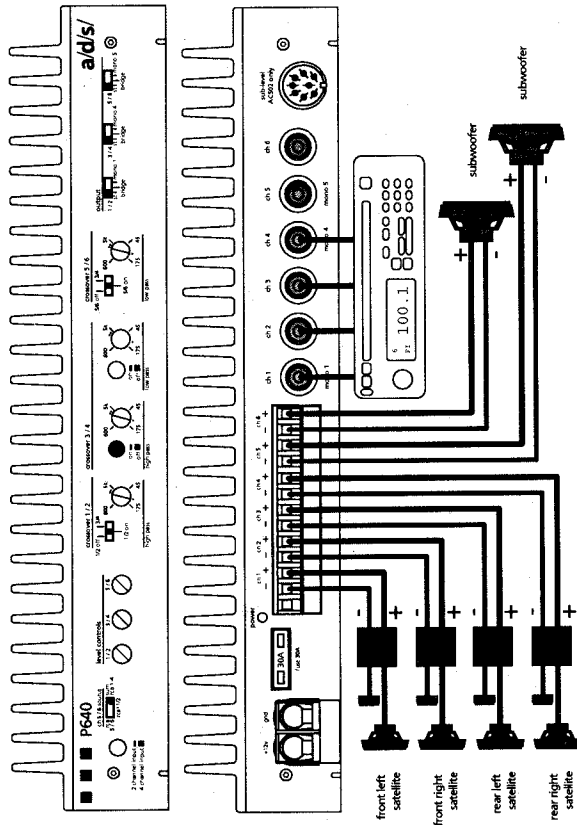

Note: Optional AC502 can be used in this system to adjust the level of the subwoofers.

- Button is disengaged.
- Button is engaged.

System 2— P640 used in 5 channel mode with the AC502 providing level control for bridged channels 5 & 6. Channels 1 and 2 are high-passed for front speakers and channels 3 and 4 are high-passed for rear speakers. Although shown as a 4 channel input, the source unit can be either 2 or 4 channel depending on the setting of the 2/4 channel switch.

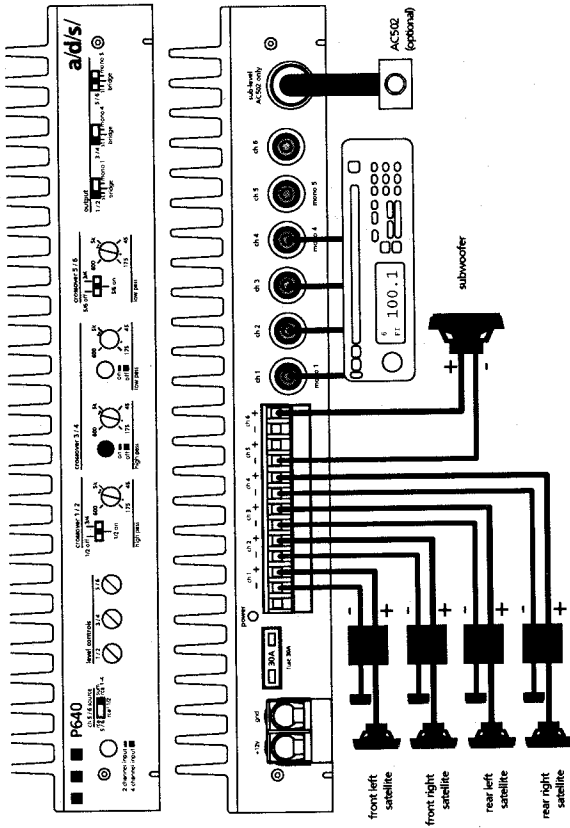

System 3— P640 used in 6 channel mode with the source unit providing direct level control for channels 1 & 2 through the fader control. Channels 1 & 2 are configured high-pass for tweeters, channels 3 & 4 are configured bandpass for midrange and channels 5/6 are configured low-pass for subwoofers.

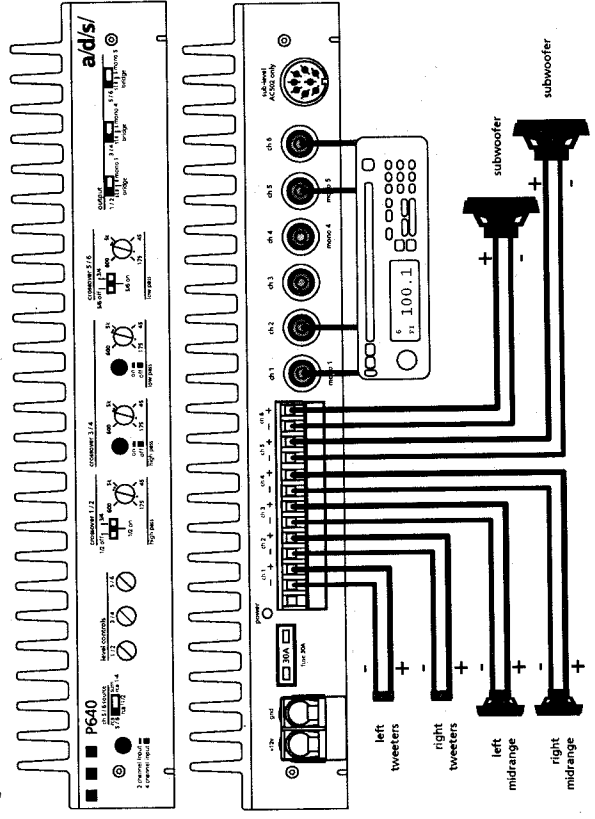

System 4—P640 used in 4 channel mode with high-pass tweeters and bandpass midrange. Channels 1 & 2 are configured high-pass for the main tweeters and channels 3 & 4 and 5 & 6 are configured bandpass for main midrange. Channels 5 & 6 are controlled by the 3/4 level control and crossover section. The amplifier is configured for a 2 channel input.

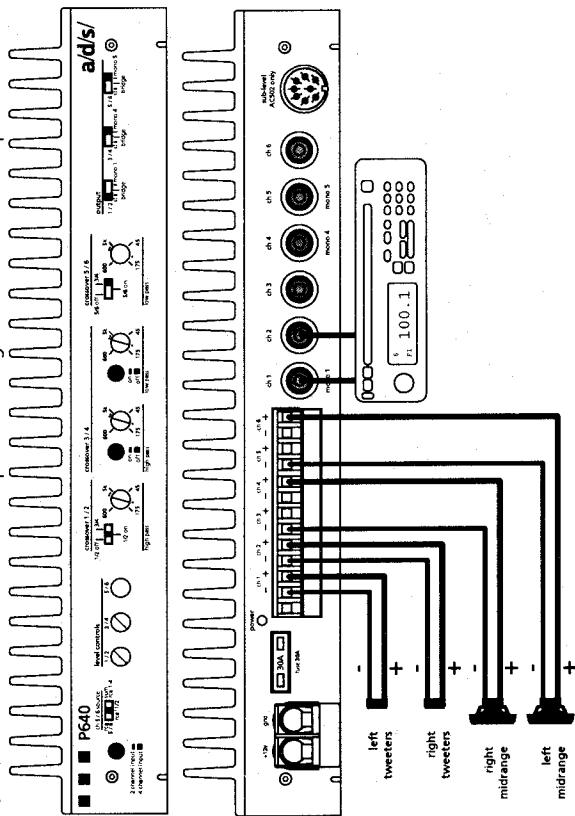

System 5—P640 used in 4 channel mode with high-pass main speakers and low-pass subwoofers. Channels 1 & 2 are configured high-pass for front speakers and channels 3 & 4 and 5 & 6 are configured low-pass for bridged output subwoofers. The amplifier is configured for a 4 channel input. Front / rear fader adjust subwoofer level.

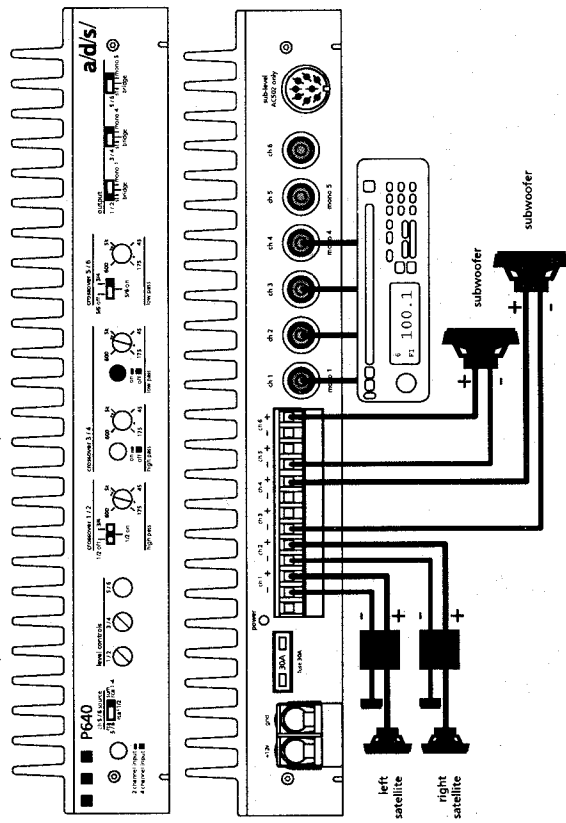

System 6—P640 used in three channel bridged mode with two channels dedicated for the main speakers and one bridged channel pair used for a subwoofer. Channels 1 & 2 and 3 & 4 are configured high-pass for the main front speakers using a single pair of RCA input to produce a bridged-mono output.

Note: Optional AC502 is used in this system to adjust the level of the subwoofers.

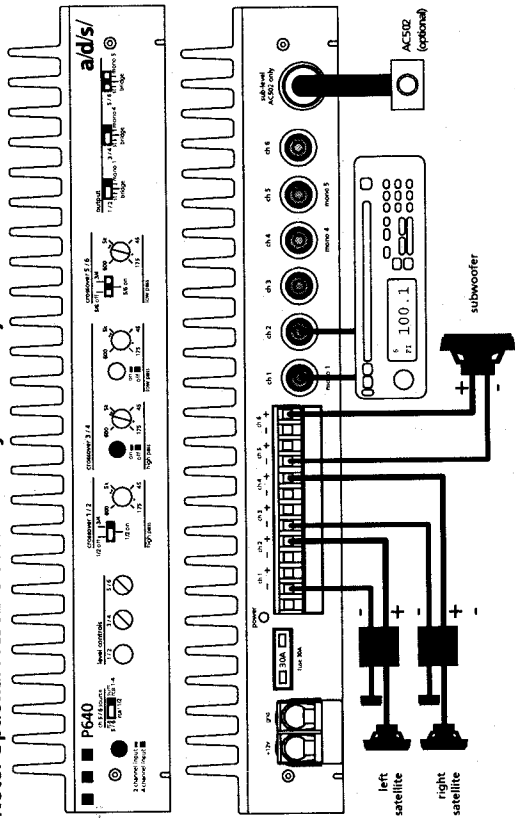

System 7 - Two P640 are used. The first P640 is configured the same as system 4 and the second P640 is configured the same as system 5. The first amplifier drives the front midrange and tweeters and the second amplifier drives the rear speakers and the subwoofer.

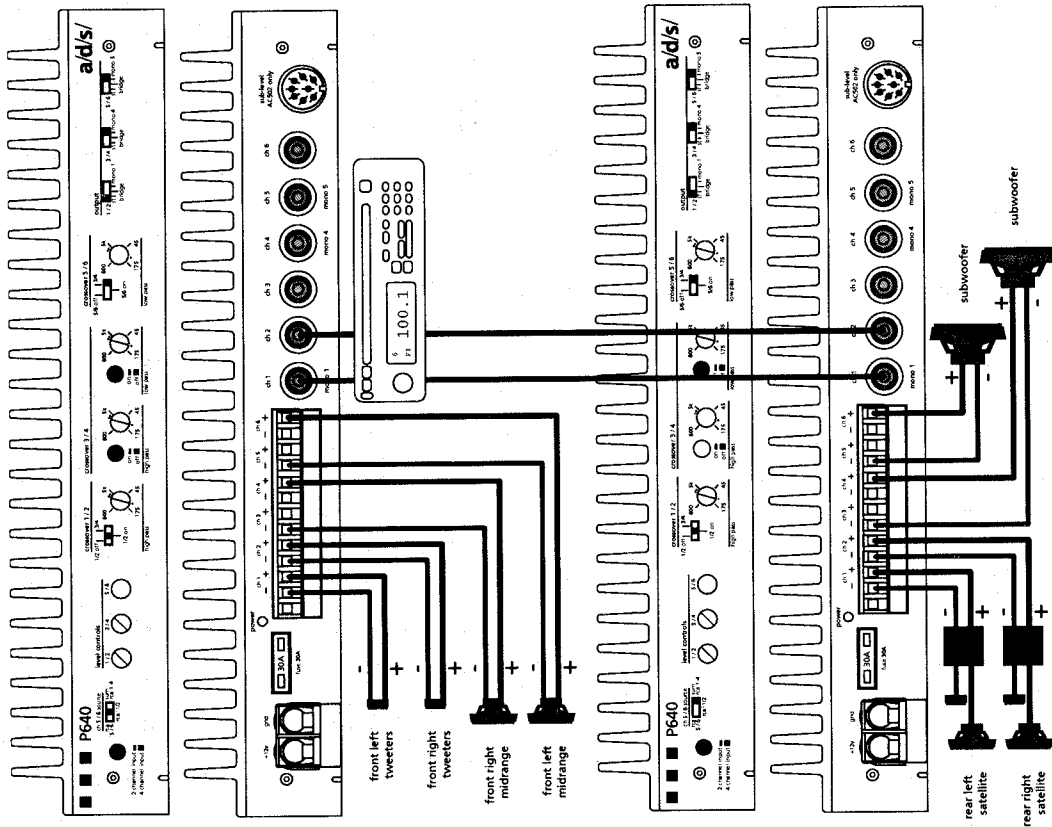

Note: ACS02 will not function in this system.

mounting locations

Due to its low profile and small size there are many possible choices of mounting locations. Always mount the PowerPlate™ in a place that protects it from the elements. In addition mount the PowerPlate™ on a stable flat mounting surface. Whenever possible, pre-drill the mounting holes. Remember to check behind the panel for hidden dangers in the form of hoses, fuel or brake lines or electrical wiring. Use a marking pen or awl to mark the hole locations and pre-drill using a 1/8" bit.

Run all the wires to the mounting location in advance of the final mounting.

Passenger compartment mounting All PowerPlates have been designed with a low profile to make under seat mounting possible. Regardless of where you choose to mount your PowerPlate™ be sure keep a minimum of 1" of clearance around the amplifier for adequate airflow to prevent overheating.

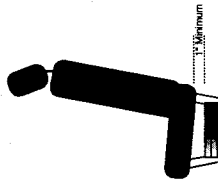

Trunk compartment mounting The most common mounting location is in the trunk or cargo compartment. For optimum cooling, mount the PowerPlate™ chassis vertically with the fins running vertically, or mount the PowerPlate™ horizontally with the fins pointing upward. Avoid horizontal mounting locations with the fins pointing downwards.

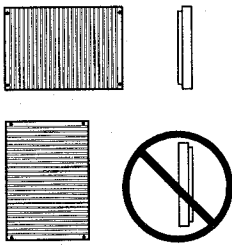

Also, locate the PowerPlate™ where it, and connections to it, will not be damaged by cargo or tools which may shift during vehicle operation.

Engine compartment mounting Don't even think about it! The PowerPlate™ was not designed to endure the harsh chemical and heat environment of the engine compartment. Failure to obey this warning will void your warranty.



installation

1. Disconnect the battery ground wire. Reconnect the cable only after the installation is complete and the wiring has been checked to make sure that there are no problems. If your radio features a code type security system be sure you know the code before disconnecting the battery!
2. Run a minimum AWG #8 power wire directly from the battery to the PowerPlate™ mounting location. Install a fuseholder at the battery end of this cable either within 18" of the battery or before the wire runs through any metal partitions. Do not install the fuse at this time.
3. Attach a minimum AWG #8 ground wire to a solid chassis ground point near the mounting location. Keep this wire as short as possible. Scrape all paint and primer off of the sheet metal at the ground point to ensure a good electrical connection. Attach the wire to the ground point with a nut, bolt and star washer.
4. Run the signal leads and remote turn-on leads from the head unit to the PowerPlate™ location. If using an internally powered radio or factory radio refer to the "signal sources" section for the proper wiring connections.
5. Install the speakers and run each of the speaker leads to the PowerPlate™ location. Connect the speaker, remote, and power wires to the appropriate terminals on the plug-in terminal blocks. Refer to the "controls and connections" or "system planning" sections for information on the proper connections. The terminal blocks install with the set screws facing down.
6. Preset the 2/4 channel selector switch, crossover and channel mode switches, and crossover frequency switches to the desired positions. Refer to the "controls and connections" section for more information.
7. Adjust all amplifier input level controls to the 1/4 position.
8. Mount the amplifier into position and plug in the power and speaker terminals. Attach the input signal cables.
9. Reattach the battery ground wire.
10. Double check your switch and control settings. Install a 30A fuse in the fuseholder you have installed near the battery.
11. Turn on the signal source at a low volume level. Using the balance and fader controls, check to see that each channel is connected to the proper speakers. Make sure that the proper frequency range is being sent to each speaker if you are using the crossover features built in to your PowerPlate™.
12. Adjust the input sensitivity and crossover frequencies as described in the "tuning" section.
13. Read the rest of the manual to get maximum use and enjoyment from your system.

controls and connections

power connections

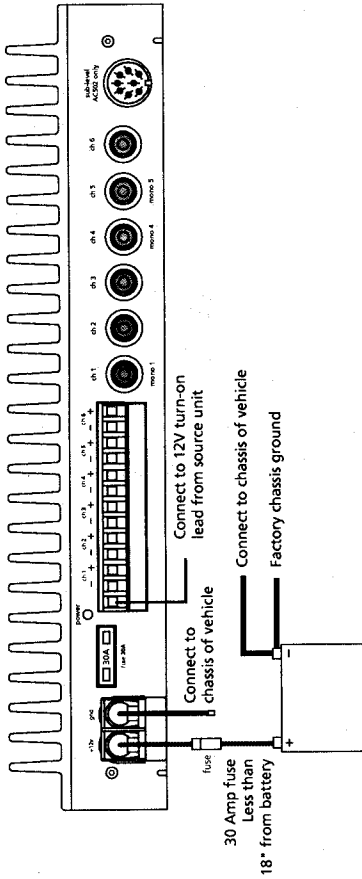

Use AWG#8 or larger power and ground cable.

Install a 30A fuse in the power wire within 18" of the battery.

Keep the Ground wire to a minimum length and attach solidly to a clean metal part of the vehicle. The addition of a 0.5 Farad to 1 Farad power supply capacitor, mounted as close as possible to the PowerPlate™, may improve performance in some systems.

speaker connections for stereo configurations

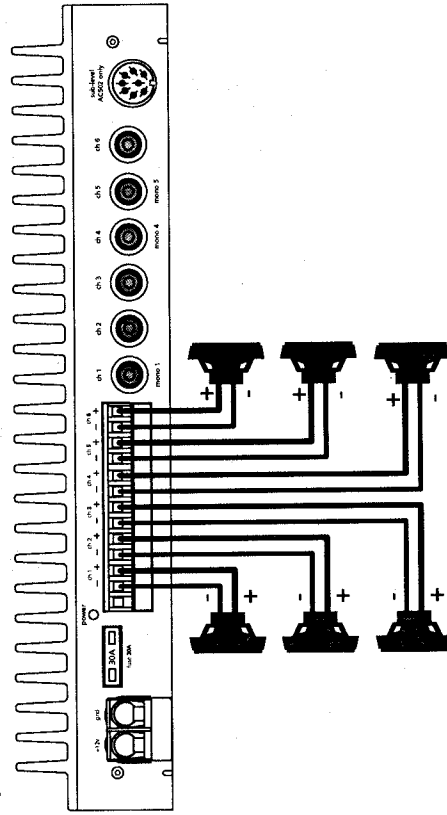

Minimum recommended impedance is 2-Ohm stereo.

Speaker terminals accept up to AWG#12 speaker wire.

Speaker connections for bridged configurations

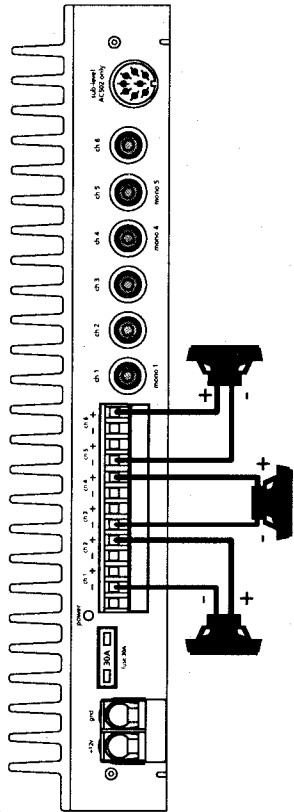

Minimum recommended impedance 3-Ohm when bridged to subwoofers and 4-Ohm when bridged to full-range speakers.

Speaker terminals accept up to 12 gauge speaker wire.

Internal signal routing

2 channel / 4 channel input switch - routes RCA input from channels 1/2 to channels 3/4. When the switch is engaged, channel 1 input is routed to both channels 1 and 3 with input channel 2 routed to amplifier channels 2 and 4

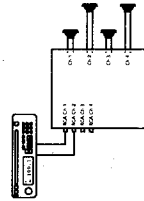

Switch in the engaged position.

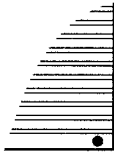

When the Switch is disengaged, Channels 1,2,3 and 4 receive signal individually from their respective inputs

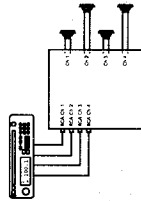

Switch in the disengaged position.

Channels 5/6 input switch

When the switch is in the left position, Channels 5/6 accepts input from the 5/6 RCA inputs



When the switch is in the center position, channels 5/6 receive input from channels 1/2 RCA input.



When the switch is in the right position, channels 5/6 receive input from the summed input of channels 1,2,3 and 4 RCA input. Channel 5 receives the summed input of channels 1 and 3. Channel 6 receives the summed input of channels 2 and 4.



Level Controls- Independent level controls for channels 1/2, 3/4 and 5/6 adjust the input sensitivity from 90 mV to 5 VRMS.

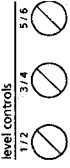

Note: When crossover 3/4 is selected for channels 3/4 and 5/6, the 3/4 level controls adjust the output level for channels 3/4 and 5/6 simultaneously.

Output Three position switches determine output configuration. Each pair of channels can be configured for either stereo, summed-bridged or bridged-mono.

When the switch is in the left position, the output channels are configured for stereo operation.

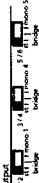

When the switch is in the center position, the output is configured for summed-bridged operation by mixing the left and right input signals together.



When the switch is in the right position, the output channels are configured for a bridged-mono output using a single RCA input. ch 1 input is used for channels 1 & 2, ch 4 input is used for channels 3 & 4 and ch 5 is used for channels 5 & 6.



Using the AC502 (optional)

The AC502 remote level control, available as an accessory from your a/d/s/ dealer, may be used with your PowerPlate™ to remotely adjust the gain of the summing network output. The network is selected by switching the ch 5/6 source to its right position. This provides the useful ability of adjusting the subwoofer level easily from the listening area. To use this feature, simply connect the AC502 into the DIN connector on the P640, and install the AC502 in the desired location. Refer to the Adjustments section for information on setting up the AC502 for the appropriate adjustment range.

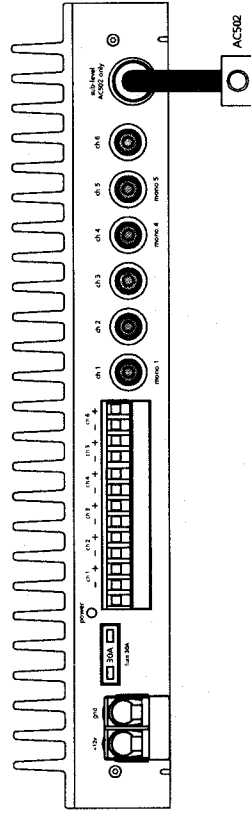

multi-cross™ crossover configuration

xover control 1/2 The crossover selection for channels 1 & 2 has three possibilities.

When the switch is in the left position, the crossover section of the amplifier is by-passed. Channels 1 & 2 output is full range.

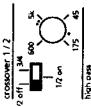

When the switch is in the center position, channels 1 & 2 are filtered through a 12 dB/Octave high-pass crossover that is infinitely variable from 45 Hz to 5,000 Hz.

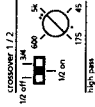

When the switch is in the right position, channels 1 & 2 receive signal from the crossover output of channels 3 & 4. **NOTE:** When the switch is in the right position, the output level is controlled by the ch 3/4 level control.

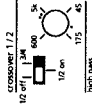

xover control 3/4 The crossover section dedicated for channels 3 & 4 are activated by depressing the switch next to the frequency adjustment control. Both high-pass and low-pass crossovers are infinitely adjustable from 45 Hz to 5,000 Hz. The high-pass and low-pass sections may be combined to create a bandpass filter.

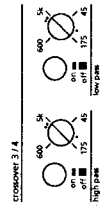

Note: When using both sections to create a bandpass filter, make sure you have selected a low-pass frequency that is higher than the high-pass frequency!

xover control 5/6 The crossover selection for channels 5 & 6 have three possibilities.

When the switch is in the left position, the crossover section of the amplifier is by-passed. Channels 5 & 6 output is full range.

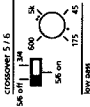

When the switch is in the center position, channels 5 & 6 are filtered through a 12 dB/Octave low-pass crossover that is infinitely variable from 45 Hz to 5,000 Hz.

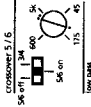

When the switch is in the right position, channels 1 & 2 receive signal from the crossover output of channels 3 & 4. **NOTE:** When the switch is in the right position, the output level is controlled by the ch 3/4 level control.

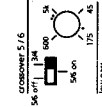

tuning

tuning the crossover All of the crossover controls in the multi-cross™ crossover section are marked at four reference frequency points. These are 45 Hz, 175 Hz, 600 Hz and 5,000 Hz. Specific crossover points should be chosen based on the operating range recommended by the manufacturer of your speakers. In addition there are three small dots on the frequency range dial representing commonly used a/d/s/ crossover frequency recommendations. These are 85Hz, 2,500Hz and 3,500Hz respectively.

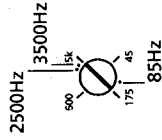

The 85Hz position is a good starting point to use for subwoofer low-pass or midrange high-pass use. When bi-amping a/d/s/ loudspeaker components 2500Hz. is a good starting point for the midrange low-pass, and 3500Hz. is recommended as the tweeter high-pass. Once installed, you can fine-tune the crossover points using your ears or with the aid of an RTA to achieve maximum performance. With any loudspeaker, minor deviations from the recommended frequency ranges may provide superior results, depending on your speaker locations and your vehicle's acoustics. Setting crossover frequencies higher than recommended will not cause damage and may provide good results. However, **DO NOT** set high pass tweeter crossovers below the tweeters recommended operating range. Doing so will likely cause damage not covered by the manufacturers warranty. If you are using non-a/d/s/ speakers, refer to the manufacturers recommendation for selecting the proper crossover frequencies.

adjusting input sensitivity The input sensitivity setting is important to ensure proper performance, low noise levels, and maximum system reliability. As a general rule, components at the "front end" of the system should be set as high as possible with the input sensitivity of the amplifier set as low as possible while still providing adequate volume levels. Using a high signal level from the source, and a low input sensitivity setting on the amplifier will keep the background noise levels of the system low. The following procedure will help you get the widest dynamic range from your system.

1. Start with the input level controls of your PowerPlate™ at the minimum (Counterclockwise) position.
2. Set the tone controls and any controls on any equalizers or other signal processors to their flat or bypassed positions.
3. Set the input and output level controls, if any, on any associated equipment such as equalizers or onboard electronic crossovers as recommended by their manufacturers.
4. Select a well recorded CD or Tape containing material recorded at a fairly high level. Musical content is not important except that the music chosen should be recorded such that any system distortion can be clearly heard, not masked by musical content.
5. Increase the source unit volume control about halfway. Increase the PowerPlate™ level control associated with the front full-range (or midrange in a bi-amplified front system) until you can hear sound at a low but clear level.
6. While listening carefully for any signs of distortion, slowly increase the source unit volume control until you either hear the first signs of distortion or you can't turn it up any more. Back down on the volume control slightly until the distortion goes away. You have just found the maximum undistorted output level of your source unit. Do not exceed this level in normal operation, doing so will just send a distorted signal to the rest of the system.
7. Returning to the PowerPlate™ level control associated with the front main speakers, slowly increase it until you reach the point where distortion just begins to appear. This will be at the point where either the amplifier reaches its maximum output level, or the speakers reach their output limits. Either way, you have just calibrated the system so that the maximum system output occurs at the same point as the maximum output from the source. This will give you minimum system noise yet the system will reach its maximum output capability.
8. Reduce the source unit volume to a comfortable listening level. With the balance and fader controls still centered, adjust the remaining level controls for the proper system balance. If you are using a single P640, the remaining speakers are probably rear speakers and subwoofers. If you are adjusting a system with multiple speakers, it is easiest to adjust the controls in the following order: 1. Front speakers 2. Rear speakers 3. Subwoofers
9. If using an AC502 remote level control, adjust the subwoofer level with the AC502 in the mid position. This will give you the ability to boost the subwoofer level approximately 6dB when the AC502 is turned fully clockwise.
10. Double-check your system levels by increasing the source unit volume control to the previously determined maximum position. If you hear distortion from any of the channels, reduce the PowerPlate™ input level control for those channels until the distortion goes away.

Adjusting the input levels this way will get maximum undistorted output from your system, and will make it unlikely that you will cause damage to any of the components of your system by overpowering them.

troubleshooting

symptom

No output

probable cause

Low or no remote turn-on input

action to take

Check remote turn-on voltage output at amplifier and fix as needed

Fuse blown

Check power wire integrity and for reversed polarity. Fix as needed and replace fuse

Power wires not connected

Check power wire and ground connections and fix or replace as needed

Audio input not connected or no output from source.

Check RCA connections and signal integrity, fix or replace as needed

Speaker wires not connected

Check speaker wires and fix or replace as needed

Speakers are blown

Check system with known working speaker and fix or replace speakers as needed

Thermal protection engage when amplifier heatsink temperature exceeds 90°C

Make sure there is proper ventilation for amplifier and improve ventilation as needed

Loose or poor audio input

Check RCA connections and fix or replace as needed

Loose power connections

Check power wire and ground connections and fix or replace as needed

Distorted output

Amplifier level sensitivity set too high. Exceeding maximum capability of amplifier

Reset gain. Refer to the tuning section of this manual for detailed instructions

Impedance load to amplifier too low.

Check speaker impedance load, if below 2Ω stereo or 4Ω mono rewire speakers to achieve a higher impedance

Shorted speaker wires

Check speaker wires connections and fix or replace as needed

Speaker not connected to amplifier properly

Check speaker wiring and fix or replace as needed. Refer to the installation quick reference section of this manual for detailed instructions

Internal crossover not set properly for Speaker

Reset crossovers. Refer to the multi-cross™ crossover configuration section of this manual for detailed instructions

Speakers are blown

Check system with known working speakers and fix or replace as needed

specifications

amplifier section

power output 4Ω (watts)¹
 6 channel 6 x 40
 5 channel 4 x 40, 1 x 120
 4 channel 2 x 40, 2 x 120
 3 channel 3 x 120

power output 2Ω (watts)²
 6 x 60

distortion all channels driven 0.1%
 20Hz to 20,000Hz

frequency response ± 1dB
 10Hz to 30,000Hz

signal to noise ratio full
 bandwidth @ rated output power
 90dB

damping factor @ output
 connector full bandwidth
 >150

input sensitivity
 90mV to 5Vrms for full output

input impedance
 47 kΩ

fuse type
 30 ATC

crossover section³

ch 1 & 2
 high-pass

ch 3 & 4
 high-pass & low-pass

ch 5 & 6
 low-pass

general dimensions

1. All channels driven, continuous FTC rated 4Ω load, 20 Hz to 20,000 Hz, <0.1% THD, power input voltage at 13.8 VDC.
2. All channels driven, continuous FTC rated 2Ω load, 20 Hz to 20,000 Hz, <0.1% THD, power input voltage at 13.8 VDC.
3. All channels are selectable with infinitely variable adjustments from 45 Hz to 5,000 Hz with a slope rate of 12 dB/Octave and a "Q" of .707

symptom

Poor bass response

probable cause

Speakers wired with wrong polarity causing cancellation at low frequency

Crossover set incorrectly

action to take

Check speaker polarity and fix as needed

Reset crossovers. Refer to the multi-cross™ crossover configuration section of this manual for detailed instructions

Check speaker impedance load, if below 2Ω stereo or 4Ω mono rewire speakers to achieve a higher impedance

Check power and ground connections and fix or repair as needed

Replace with proper fuse size

Check speaker impedance load, if below 2Ω stereo or 4Ω mono rewire speakers to achieve a higher impedance

Check power and ground connections and fix or repair as needed

Check speaker impedance load, if below 2Ω stereo or 4Ω mono rewire speakers to achieve a higher impedance and replace with recommended size fuse

Check power and ground connections and fix or repair as needed

Replace with proper fuse size

Battery fuse blowing

Impedance load to amplifier too low.

Short in power wire or incorrect power connections.

Fuse used is smaller than recommended

Too much current being drawn

Amplifier fuse blowing

Too much current being drawn

Fuse used is smaller than recommended

Warranty Information

There are two things you must do to ensure trouble free service in the event you need warranty repairs.

1 - Keep your original sales receipt in a safe place. A copy of the receipt will be required to obtain warranty service.

2 - Be sure your retail dealer has written the date, the model number, and the serial number (if applicable) of the Product on the receipt.

To give yourself an extra measure of protection, make a separate record of the information about your purchase and keep it in a safe place. In the event you misplace the sales receipt, your dealer may be able to give you a copy.

Take a moment now to read the terms of your warranty. Check to be sure your sales receipt is dated and has the Product model number and serial number (if applicable) on it. Then put it away in a safe place.

When shipping a Product in for service:

- Enclose a copy of your original sales receipt that has the date, the Product model number and serial number (if applicable) written on it.
- Always ship Products in the complete original packing material.
- Avoid shipping Products via the Postal service. If you must use the Postal service, be sure to register and insure the package.

a/d/s/ Limited Warranty

Analog and Digital Systems, Inc. (a/d/s) warrants to the original consumer purchaser of the a/d/s/ Products described in this manual, that the Product will be free from defects in materials and workmanship for a period of one (1) year after the date of purchase. If the product is installed by an authorized a/d/s/ retail dealer, the warranty is extended to three (3) years. a/d/s/ sole obligation under this warranty shall be to provide, without charge, parts and labor necessary to remedy the defects, if any, that appear during the warranty period.

This warranty is the sole and exclusive express warranty given with respect to the Product. All other express warranties are hereby excluded. Neither a/d/s/ nor the authorized dealer who sells the Product is responsible for indirect, incidental, or consequential damages. Some states do not allow the exclusion or limitation of incidental or consequential damages, so the above limitation or exclusion may not apply to you. This warranty gives you specific legal rights and you may also have other rights which vary from state to state.

IMPORTANT - Keep your original sales receipt. Be sure the retail dealer has written on it the date, model number, and serial number (if applicable) of the Product. This information is required for warranty service.

This warranty is limited to:

- Products purchased from authorized a/d/s/ retail dealers in the United States. a/d/s/ will supply a list of authorized dealers on request.

In order to obtain warranty service you must:

- Return the Product, freight prepaid, to the a/d/s/ dealer from which it was purchased, an authorized a/d/s/ independent service agency, or to a/d/s/, if necessary you may call a/d/s/ Customer Service Department for the names and addresses of authorized independent service agencies in your area.
- Provide proof of purchase in the form of a copy of your original sales receipt. The date, model number, and serial number (if applicable) of the Product must be written on the sales receipt.

This warranty does not cover:

- Damage that is the result of misuse, abuse, accident (including but not limited to damage by water), faulty hookup, defective or maladjusted associated equipment, or the use of the Product with equipment for which it was not intended.
- Cosmetic defects that appear more than thirty (30) days after the date of purchase. Cosmetic damage caused by improper handling is also excluded.
- Products that are used for commercial purposes.
- The cost of removing or reinstalling the Product.
- Damage that occurs while the Product is being shipped to whoever will service it. See the information above regarding shipping procedures.

This warranty is void if:

- The Product identification or serial number label is removed or defaced in any way.
- The Product is serviced or repaired by any one other than a/d/s/ or an authorized a/d/s/ dealer or service agency.