

Model 1200XP

Installation Guide

Directed[®]
ELECTRONICS, INC.

© 2003 Directed Electronics, Inc. Vista, CA N561P 06-03

table of contents

what is included	3	optional anti-grind relay	23
warning! safety first	4	door lock wiring guide	24
installation points to remember	5	type A: (+) 12V pulses from the switch to the .	
finding the wires you need.	6	factory relays	24
obtaining constant 12V	6	type B: (-) pulses from the switch to the	
finding the starter wire	6	factory relays	25
finding the 12V switched ignition wire	7	type C: reversing polarity	26
finding the accessory wire.	7	type D: after-market actuators	27
finding a (+) parking light wire	8	type E: mercedes-benz and audi (1985 & newer)	
finding the tachometer wire	8	27
finding the wait-to-start bulb wire for diesels .	9	type F: one-wire system	28
primary harness (H1) wiring diagram	10	type G: positive (+) multiplex	28
4-pin satellite harness diagram	10	type H: negative (-) multiplex	29
heavy gauge relay satellite wiring diagram	11	programming jumpers	30
door lock harness, 3-pin connector	11	light flash (+)/(-)	31
remote start harness (H2) wiring diagram.	11	tach threshold on/off.	31
primary harness (H1), 9-pin connector	12	plug-in program switch	31
relay key switch interface	16	transmitter/receiver learn routine.	32
remote start harness (H2), 5-pin connector.	17	tach learning.	34
neutral safety switch interface	18	to learn the tach signal	34
general motors trucks, SUVs, and column		operating settings learn routine	34
pre-1996 dodge dakota pickups with 2.5 liter .		features menu	36
motors	20	feature descriptions.	36
shifting passenger cars	20	shutdown diagnostics.	38
bypassing GM vehicle anti-theft systems		timer mode	39
(VATS)	21	safety check	40
1995 and newer vehicle anti-theft systems		troubleshooting.	41
(immobilizers)	22	wiring quick reference guide	43
passlock I and passlock II (PL-1 and PL-2)	22		
passkey III (PK-3), transponder-based systems .			
.	22		

Bitwriter™, Code Hopping™, Doubleguard®, ESP™, FailSafe®, Ghost Switch™, Learn Routine™, Nite-Lite®, Nuisance Prevention Circuitry®, NPC®, Revenger®, Silent Mode™, Soft Chirp®, Stinger®, Valet®, Vehicle Recovery System®, VRS®, and Warn Away® are all Trademarks or Registered Trademarks of Directed Electronics, Inc.

what is included

- The control module (see diagram)
- One 473P remote transmitter
- The plug-in program switch
- A hood pinswitch
- A toggle override switch
- XHF antenna receiver

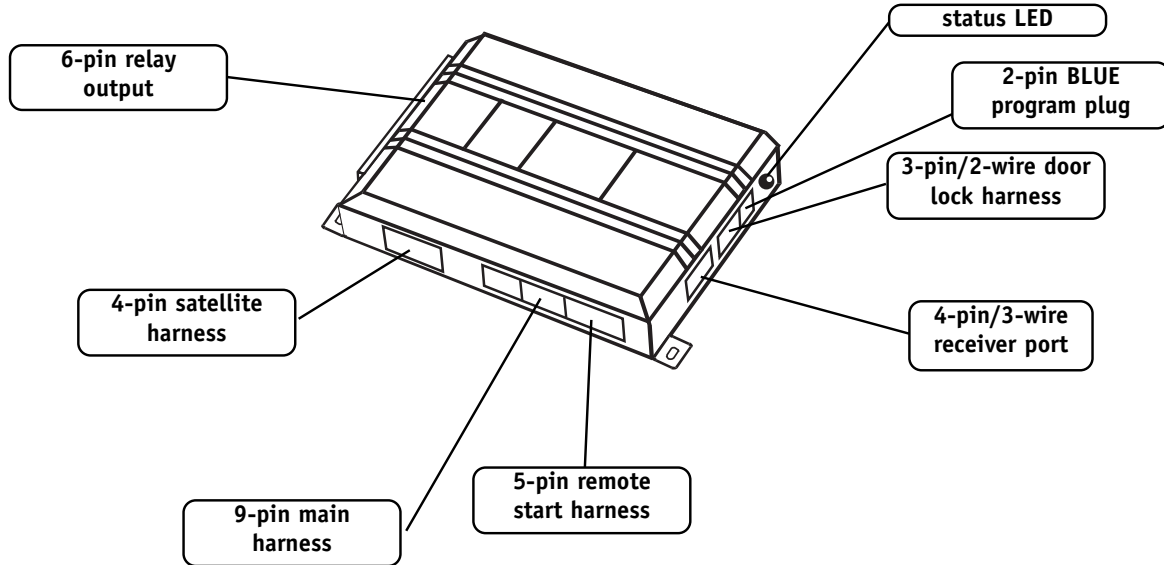

warning! safety first

The following safety warnings must be observed at all times:

- Due to the complexity of this system, installation of this product must only be performed by an authorized Directed Electronics dealer.
- When properly installed, this system can start the vehicle via a command signal from the remote control transmitter. Therefore, never operate the system in an area that does not have adequate ventilation. The following precautions are the sole responsibility of the user; however, authorized Directed Electronics dealers should make the following recommendations to all users of this system:
 1. Never operate the system in an enclosed or partially enclosed area without ventilation (such as a garage).
 2. When parking in an enclosed or partially enclosed area or when having the vehicle serviced, the remote start system must be disabled using the installed toggle switch.
 3. It is the user's sole responsibility to properly handle and keep out of reach from children all remote control transmitters to assure that the system does not unintentionally remote start the vehicle.
 4. **THE USER MUST INSTALL A CARBON MONOXIDE DETECTOR IN OR ABOUT THE LIVING AREA ADJACENT TO THE VEHICLE. ALL DOORS LEADING FROM ADJACENT LIVING AREAS TO THE ENCLOSED OR PARTIALLY ENCLOSED VEHICLE STORAGE AREA MUST AT ALL TIMES REMAIN CLOSED.**
- Use of this product in a manner contrary to its intended mode of operation may result in property damage, personal injury, or death. Except when performing the Safety Check outlined in this installation guide, (1) Never remotely start the vehicle with the vehicle in gear, and (2) Never remotely start the vehicle with the keys in the ignition. The user will be responsible for having the neutral safety feature of the vehicle periodically checked, wherein the vehicle must not remotely start while the car is in gear. This testing should be performed by an authorized Directed Electronics dealer in accordance with the Safety Check outlined in this product installation guide. If the vehicle starts in gear, cease remote start operation immediately and consult with the user to fix the problem immediately.
- After the remote start module has been installed, test the remote start module in accordance with the Safety Check outlined in this installation guide. If the vehicle starts when performing the Neutral Safety Shutdown Circuit test, the remote start unit has not been properly installed. The remote start module must be removed or properly reinstalled so that the vehicle does not start in gear. All installations must be performed by an authorized Directed Electronics dealer. **OPERATION OF THE REMOTE START MODULE IF THE VEHICLE STARTS IN GEAR IS CONTRARY TO ITS INTENDED MODE OF OPERATION. OPERATING THE REMOTE START SYSTEM UNDER THESE CONDITIONS MAY RESULT IN PROPERTY DAMAGE OR PERSONAL INJURY. IMMEDIATELY CEASE THE USE OF THE UNIT AND REPAIR OR DISCONNECT THE INSTALLED REMOTE START MODULE. DIRECTED ELECTRONICS, INC. WILL NOT BE HELD RESPONSIBLE OR PAY FOR INSTALLATION OR REINSTALLATION COSTS.**

installation points to remember

IMPORTANT! *This product is designed for fuel-injected, automatic transmission vehicles only. Installing it in a standard transmission vehicle is dangerous and is contrary to its intended use.*

Before beginning the installation:

- Please read this entire installation guide before beginning the installation. The installation of this remote start system requires interfacing with many of the vehicle's systems. Many new vehicles use low-voltage or multiplexed systems that can be damaged by low resistance testing devices, such as test lights and logic probes (computer safe test lights). Test all circuits with a high quality digital multi-meter before making connections.
- Do not disconnect the battery if the vehicle has an anti-theft-coded radio. If equipped with an air bag, avoid disconnecting the battery if possible. Many airbag systems will display a diagnostic code through their warning lights after they lose power. Disconnecting the battery requires this code to be erased, which can require a trip to the dealer.
- Remove the dome light fuse. This prevents accidentally draining the battery.
- Roll down a window to avoid being locked out of the vehicle.

After the installation:

- Test all functions. The "Using Your System" section of the Owner's Guide is very helpful when testing.
- Complete the vehicle *Safety Check* outlined in this manual prior to the vehicle reassembly.

finding the wires you need

IMPORTANT! Do not use a 12V test light or logic probe (computer safe test light) to locate these wires! All testing described in this manual assumes the use of a digital multimeter.

obtaining constant 12V

We recommend two possible sources for 12V constant: The (+) terminal of the battery, or the constant 12V supply to the ignition switch. Always install a fuse within 12 inches of this connection. If the fuse will also be powering other circuits, such as door locks, a power window module, or a Nite-Lite® headlight control system, fuse accordingly.

IMPORTANT! Do not remove the fuse holder on the red wire. It ensures that the control module has its own fuse, of the proper value, regardless of how many accessories are added to the main power feed.

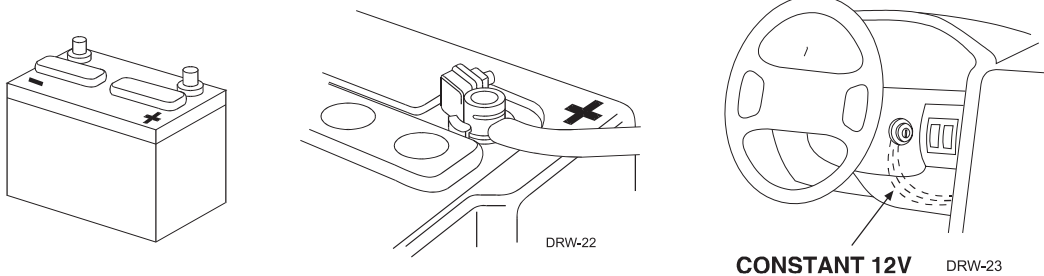

finding the starter wire

The starter wire provides 12V directly to the starter or to a relay controlling starter. In some vehicles, it is necessary to power a cold start circuit. A cold start circuit will test exactly like a starter circuit, but it does not control the starter. Instead, the cold start circuit is used to prime the fuel injection system for starting when the vehicle is cold.

How to find the starter wire with your multimeter:

1. Set to DCV or DC voltage (12V or 20V is fine).
2. Attach the (-) probe of the meter to chassis ground.
3. Probe the wire you suspect of being the starter wire. The steering column is an excellent place to find this wire. Remember you do not need to interrupt the starter at the same point you test it. Hiding your starter kill relay and connections is always recommended.
4. Turn the ignition key switch to the start position. Make sure the car is not in gear! If your meter reads (+)12V, go to the next step. If it doesn't, probe another wire.

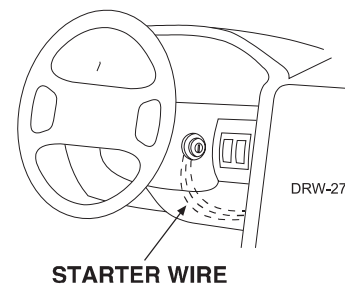

5. Cut the wire you suspect of being the starter wire.
6. Attempt to start the car. If the starter engages, reconnect it and go back to Step 3. If the starter does not turn over, you have the right wire.

finding the 12V switched ignition wire

The ignition wire is powered when the key is in the run or start position. This is because the ignition wire powers the ignition system (spark plugs, coil) as well as the fuel delivery system (fuel pump, fuel injection computer). Accessory wires lose power when the key is in the start position to make more current available to the starter motor.

How to find (+)12V ignition with your multimeter:

1. Set to DCV or DC voltage (12V or 20V is fine).
2. Attach the (-) probe of the meter to chassis ground.
3. Probe the wire you suspect of being the ignition wire. The steering column harness or ignition switch harness is an excellent place to find this wire.
4. Turn the ignition key switch to the run position. If your meter reads (+)12V, go to the next step. If it does not read (+)12V, probe another wire.
5. Now turn the key to the start position. The meter display should stay steady, not dropping by more than a few tenths of a volt. If it drops close to or all the way to zero, go back to Step 3. If it stays steady at (+)12V, you have found an ignition wire.

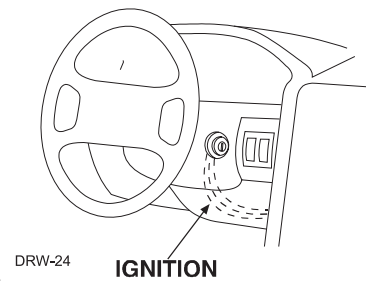

finding the accessory wire

An accessory wire will show (+)12V when the key is in the accessory and run positions. It will not show (+)12V during the cranking cycle. There will often be more than one accessory wire in the ignition harness. The correct accessory wire will power the vehicle's climate control system. Some vehicles may have separate wires for the blower motor and the air conditioning compressor. In such cases, it will be necessary to add a relay to power the second accessory wire.

finding a (+) parking light wire

Most vehicles use a (+) parking light circuit. The (+) parking light wire is often found near the light switch. In many vehicles the light switch is built into the turn signal lever; in these vehicles the parking light wire can be found in the steering column. The same wire can often be accessed in the kick panel or running board.

NOTE: Many Toyotas and other Asian vehicles, send a (-) signal from the switch to a relay. The relay then sends (+)12V to the bulbs. Whenever you have difficulty finding a (+) parking light wire near the switch, simply test the wires at any switch or control panel that is lit by the instrument panel lighting. Remember, you need a (+) parking light wire that does not vary with the dimmer setting.

How to find a (+) parking light flash wire with your multimeter:

1. Set to DCV or DC voltage (12V or 20V is fine).
2. Attach the (-) probe of the meter to chassis ground.
3. Probe the wire you suspect of being the parking light wire. Usually, the area near the headlight/parking light switch is an excellent area to start, as is the kick panel.
4. Turn on the parking lights. If your meter shows (+)12V, turn off the parking lights and make sure it goes back to zero.
5. If it does return to zero, turn the parking lights back on and, using the dash light dimmer control, turn the brightness of the dash lights up and down. If the meter changes more than a volt when using the dimmer, look for another wire. If it stays relatively close to (+)12V, you have found your parking light wire.

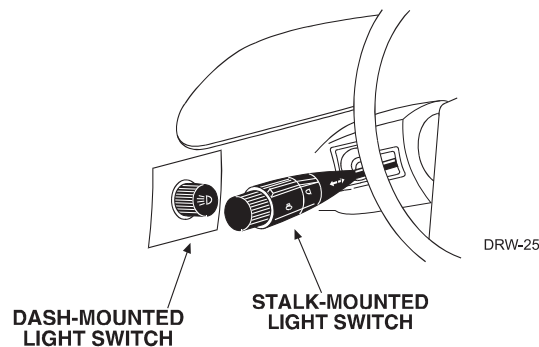

NOTE: Vehicles that use a (-) signal from the switch to the factory relay may be interfaced directly. (See H1/5 WHITE wire of Primary Harness (H1) Wire Connection Guide section.)

finding the tachometer wire

To test for a tachometer wire, a multimeter capable of testing AC voltage must be used. The tachometer wire will show between 1V and 6V AC. In multi-coil ignition systems, the system can learn individual coil wires. Individual coil wires in a multi-coil ignition system will register lower amounts of AC voltage. Also, if necessary, the system

can use a fuel injector control wire for engine speed sensing. Common locations for a tachometer wire are the ignition coil itself, the back of the gauges, engine computers, and automatic transmission computers.

IMPORTANT! *Do not test tachometer wires using a test light or logic probe. The vehicle will be damaged.*

How to find a tachometer wire with your multimeter:

1. Set to ACV or AC voltage (12V or 20V is fine).
2. Attach the (-) probe of the meter to chassis ground.
3. Start and run the vehicle.
4. Probe the wire you suspect of being the tachometer wire with the red probe of the meter.
5. If this is the correct wire the meter will read between 1V and 6V.

finding the wait-to-start bulb wire for diesels

In diesel vehicles it is necessary to interface with the wire that turns on the WAIT-TO-START light in the dashboard. This wire illuminates the bulb until the vehicle's glow plugs are properly heated. When the light goes out the vehicle can be started. This wire is always available at the connector leading to the bulb in the dashboard. It can also be found at the Engine Control Module (ECM) in many vehicles.

To test and determine the polarity of this wire:

1. Set your multimeter to DCV or DC voltage (12 or 20V is fine).
2. Attach the (+) probe of the meter to (+)12V.
3. Probe the wire that you suspect leads to the bulb with the (-) probe of the meter.
4. Turn the ignition switch to the ON position.
5. If the meter indicates 12 volts until the light goes out you have isolated the correct wire and the wire's polarity is negative (ground while the bulb is on).
6. If the meter reads zero volts until the light goes out and then reads 12 volts, you have isolated the correct wire and the wire's polarity is positive.

primary harness (H1) wiring diagram

H1/1	LIGHT GREEN/BLACK	FACTORY DISARM
H1/2	GREEN/WHITE	FACTORY REARM
H1/3	YELLOW	IGNITION OUT (TO ALARM)
H1/4	WHITE/BLUE	(-) ACTIVATION INPUT
H1/5	GRAY/BLACK	(-) WAIT TO START INPUT
H1/6	WHITE/RED	(+) ACTIVATION INPUT
H1/7	RED/WHITE	CHANNEL 2 (VALIDITY ONLY)
H1/8	BLACK	GROUND
H1/9	WHITE	(+/-) LIGHT FLASH

4-pin satellite harness diagram

1	BLUE	STATUS OUTPUT
2	ORANGE	ACCESSORY TRIGGER
3	PURPLE	STARTER TRIGGER
4	PINK	IGNITION TRIGGER

heavy gauge relay satellite wiring diagram

1	PINK	(+) (30 AMP) OUTPUT TO IGNITION CIRCUIT
2	PURPLE	(+) (30 AMP) OUTPUT TO STARTER CIRCUIT
3	ORANGE	(+) (30 AMP) OUTPUT TO ACCESSORY CIRCUIT
4	RED	(+) (30A) HIGH CURRENT 12V INPUT
5	PINK/WHITE	(+) PROGRAMMABLE OUTPUT FOR ACCESSORY OR IGNITION
6	RED	(+) (30A) HIGH CURRENT 12V INPUT

door lock harness, 3-pin connector

1	GREEN	(-) LOCK (+) UNLOCK OUTPUT
2	EMPTY	NOT USED
3	BLUE	(+) LOCK (-) UNLOCK OUTPUT

Refer to the Door Lock Wiring Guide section of this guide.

remote start harness (H2) wiring diagram

H2/1	BLACK/WHITE	(-) NEUTRAL SAFETY SWITCH INPUT
H2/2	VIOLET/WHITE	TACHOMETER INPUT WIRE
H2/3	BROWN	(+) BRAKE SWITCH SHUTDOWN WIRE
H2/4	GRAY	(-) HOOD PINSWITCH SHUTDOWN WIRE
H2/5	BLUE/WHITE	(-) 200 mA 2ND STATUS/REAR DEFOGGER OUTPUT

primary harness (H1), 9-pin connector

H1/1 LIGHT GREEN/BLACK (-) factory security disarm

This wire sends a negative pulse every time the remote start is activated or the doors are unlocked. This can be used to pulse the disarm wire of the vehicle's factory anti-theft device. Use a relay to send a (-) or (+) pulse to the disarm wire as shown in the following diagrams.

Relay for Negative (-) Disarm Wire

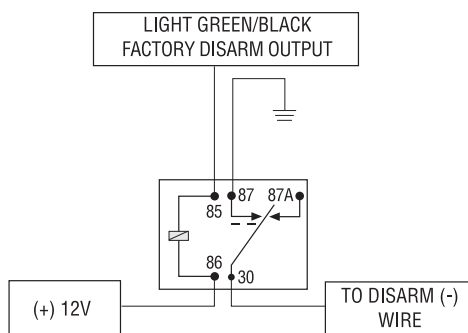

Relay for Positive (+) Disarm Wire

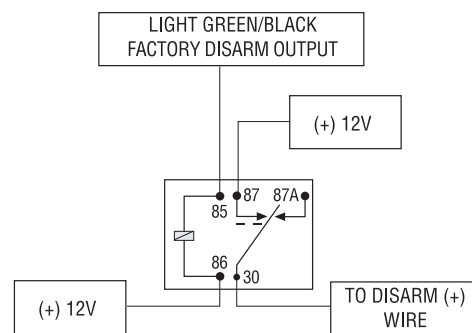

DJA-138

H1/2 GREEN/WHITE factory rearm

This wire sends a negative pulse every time the remote start shuts down or the doors are locked. This can be used to pulse the arm wire of the vehicle's factory anti-theft device. Use a relay to send a (-) or (+) pulse to the arm wire

H1/3 YELLOW (+) ignition output to RF system

As a stand-alone system: The H1/3 YELLOW wire should not be connected to anything.

As an add-on car starter: If connected, disconnect the ignition/accessory input of the remote controlled security or keyless entry system. Connect the H1/3 YELLOW ignition output to the ignition/accessory input of the remote controlled security or keyless entry system. The wire will prevent the host system from sensing that the ignition is on during remote start operation.

H1/4 WHITE/BLUE remote start (-) activation input

This input comes from the factory set to 2 activation pulses. This means that it is necessary to have 2 consecutive ground pulses on the white/blue wire for the remote start to activate or to deactivate. The same holds true for the remote control activation when set to a two pulse setting it is necessary to press the  button twice for the remote start to activate or deactivate.

NOTE: When the activation pulse count can be programmed to 1, 2, or 3 pulses when changed it will affect both activation inputs; the White/Blue wire and the remote control activation.

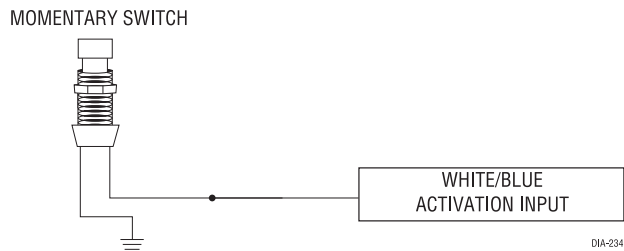

H1/5 GRAY/BLACK (-) diesel wait-to-start bulb input

Connect this wire to the wire in the vehicle that sends the signal to turn on the WAIT-TO-START bulb in the dashboard. In most diesels the wire is negative (ground turns on the bulb) and the GRAY/BLACK can be directly connected to the wire in the vehicle. If the vehicle uses a positive wire (12V to turn on the bulb) a relay must be used to change the polarity. (See *Finding the Wires You Need* section for testing procedures.) Here are some common colors of this wire:

- Chevrolet and GMC trucks: Light Blue or Dark Blue
- Ford Trucks: Black/Pink
- Dodge Ram Trucks: Orange/Black or Black/Orange

NOTE! A 1-amp diode must be installed in line on the factory wire between the wait-to-start indicator and the ECM. (See the following diagram for details.)

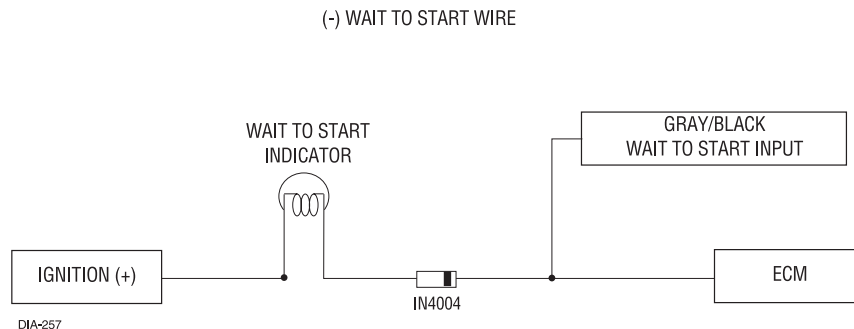

(+) WAIT TO START WIRE

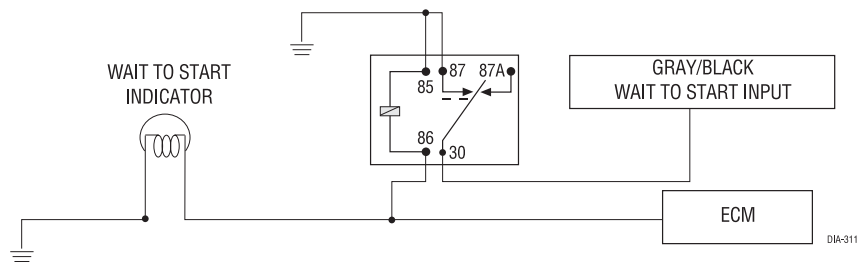

H1/6 WHITE/RED (+) activation input

This input comes from the factory set to 2 activation pulses. This means that it is necessary to have 2 consecutive 12V pulses on the white/blue wire for the remote start to activate or to deactivate. The same holds true for the remote control activation when set to a two pulse setting it is necessary to press the  button twice for the remote start to activate or deactivate.

NOTE: When the activation pulse count can be programmed to 1, 2, or 3 pulses when changed it will affect both activation inputs; the White/Red wire and the remote control activation.

H1/7 RED/WHITE Channel 2, (-) 200 mA output

When the system receives the code controlling Channel 2, for longer than 1.5 seconds, the RED/WHITE wire will supply an output as long as the transmission continues. This is often used to operate a trunk/hatch release or other relay-driven function.

IMPORTANT! Never use this wire to drive anything except a relay or low-current input! The transistorized output can only supply 200 mA of current. Connecting directly to a solenoid, motor, or other high-current device will cause it to fail.

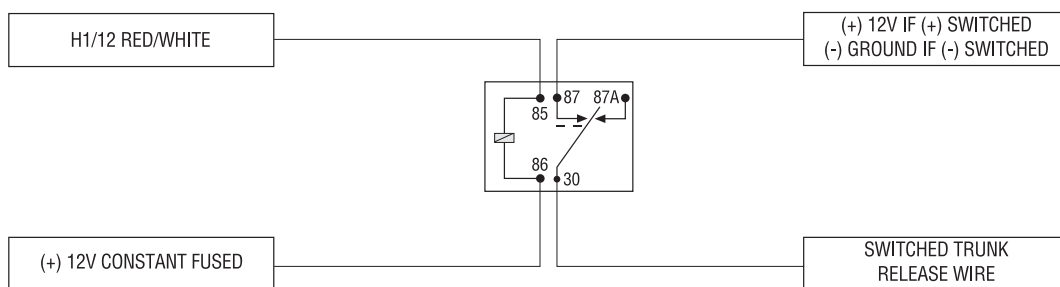

H1/8 BLACK (-) chassis ground connection

Remove any paint and connect this wire to bare metal, preferably with a factory bolt rather than your own screw. (Screws tend to either strip or loosen with time.) We recommend grounding all your components to the same point in the vehicle.

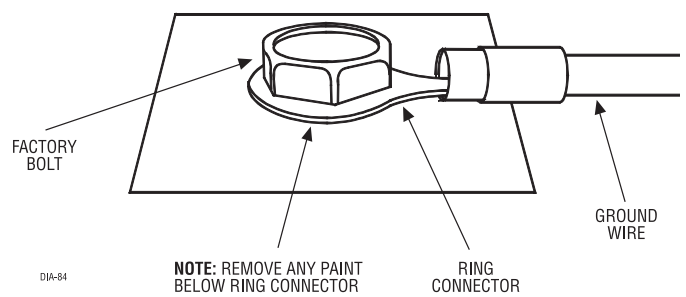

H1/9 WHITE (+/-) light flash output

IMPORTANT: Do NOT connect this wire to a negative vehicle light flash wire before changing the programming jumper to the negative polarity position or damage to the vehicle light circuit may occur.

As factory configured, the H1/9 WHITE wire should be connected to the (+) parking light wire. If the light flash polarity jumper is moved to the (-) position (refer to the Programming Jumper section of this guide), this wire then supplies (-) 200mA output. This is suitable of driving the light control (-) circuits in Toyota, Lexus, BMW some Mitsubishi, some Mazda, and other models.

NOTE: For parking light systems that draw 10 amps or more, the jumper must be placed to the (-) light flash output (refer to the Programming Jumpers section of this guide. P/N 8617 or a standard automotive SPDT relay must be used on the H1/2 light flash output wire.

(+) Positive Light Flash Output

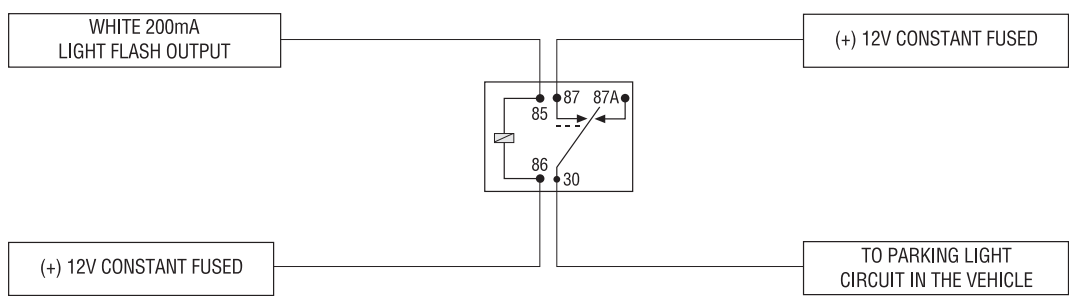

(-) Light Flash Output

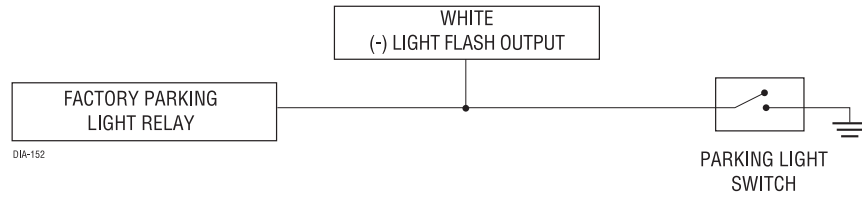

relay key switch interface

The heavy gauge wires leading from the relay satellite are used to energize high current circuits in the vehicle. It is crucial that these connections are made correctly so that they are capable of handling the current demands. For this reason, scotch locks, T-taps and other such connectors should not be used.

RED (2) (+) 12V input for relays

Remove the two 30 amp fuses prior to connecting these wires and do not replace them until the satellite has been plugged into the control module. These wires are the source of current for all the circuits the relay satellite will energize. They must be connected to a high current source. Since the factory supplies (+) 12V to the key switch that is used to operate the motor, it is recommended that these wires be connected there.

NOTE: If the factory supplies two separate (+) 12V feeds to the ignition switch, connect one RED wire of the satellite to each feed at the switch.

PINK (+) ignition output

Connect this wire to the ignition wire in the vehicle. (See *Finding the Wires You Need* section of this guide.)

ORANGE (+) accessory output

Connect this wire to the accessory wire in the vehicle that powers the climate control system. (See *Finding the Wires You Need* section of this guide.)

PURPLE (+) starter output

Connect this wire to the starter wire in the vehicle. (See *Finding the Wires You Need* section of this guide.)

PINK/WHITE (+) output to second ignition/accessory circuit

Connect this wire to the second ignition or accessory wire in the vehicle. (Selectable by using Feature 9.)

NOTE: For vehicles that do not have a second ignition or accessory wire, this connection is not required.

remote start harness (H2), 5-pin connector

H2/1 BLACK/WHITE neutral safety switch input

Connect this wire to the toggle (override) switch as shown in Figure A. Connect the other wire from the toggle switch to the PARK/NEUTRAL switch in the vehicle. This wire will test with ground with the gear selector either in PARK or NEUTRAL. This will prevent the vehicle from accidentally being started while in a drive gear. This input **MUST** rest at ground in order for the remote start system to operate. Connected properly the vehicle will only start while in PARK or NEUTRAL.

In some vehicles, the PARK/NEUTRAL position switch activates a factory starter lock-out that will not allow the starter to operate in a drive gear. In these vehicles, connect this wire to the toggle switch as shown in Figure B. Connect the other wire from the toggle switch to chassis ground.

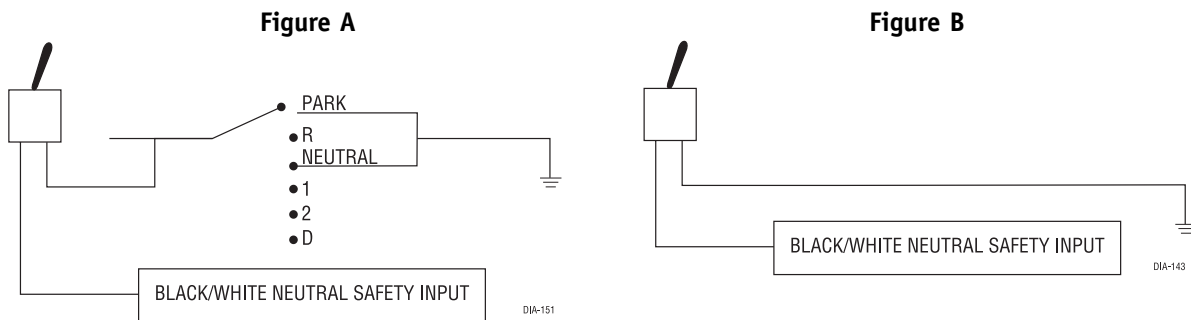

IMPORTANT! Always use the Vehicle Safety Check section of this guide to verify that the vehicle cannot be started in ANY drive gear and that the override switch is functioning properly.

H2/2 VIOLET/WHITE tachometer input

This input provides the module with information about the engine's revolutions per minute (RPMs). It can be connected to the negative side of the coil in vehicles with conventional coils. In multi-coil and high energy ignition systems locating a proper signal may be more difficult. (See *Finding the Wires You Need* section of this guide for finding the tachometer wire.) Once connected, you must teach the system the tach signal. (See *Tach Learning* section of this guide.)

H2/3 BROWN (+) brake switch input

This wire MUST be connected to the vehicle's brake light wire. This is the wire that shows (+) 12V when the brake pedal is depressed. The remote start will be disabled or shut down any time the brake pedal is depressed.

H2/4 GRAY (-) hood pinswitch input

This wire MUST be connected to the hood pinswitch. This input will disable or shut down the remote start when the hood is opened.

H2/5 BLUE/WHITE status/defogger output

This wire supplies a 200mA output as soon as the module begins the remote start process. The H2/5 BLUE/WHITE wire can also be used to activate the defogger trigger (latched/pulsed) 10 seconds after successful remote start. (See the *Feature Descriptions* section in this guide for details about programming this output.)

neutral safety switch interface

Some vehicles combine the column shift mechanism and the mechanical neutral safety switch into one mechanical part. In these vehicles, it is impossible to interface the remote start system before the neutral safety switch. With this type of vehicle, if the vehicle is left in a drive gear and the remote start system is activated, the vehicle will move and may cause damage to persons or property.

According to available information, vehicles known to be manufactured this way are most General Motors trucks, sport utility vehicles and column shifting passenger vehicles. Available information also indicates that pre-1996 Dodge Dakota pickups with 2.5 liter motors are also manufactured this way.

GM vehicles that have the neutral safety switch built into the column shifter can usually be identified by a purple starter wire. Typically, vehicles that use an outboard mechanical switch use a yellow wire from the ignition switch to the mechanical switch and a purple wire from the mechanical switch to the starter itself. Remember, this is only a rule of thumb and is not intended as a substitute for proper testing.

IMPORTANT! Please see vehicle *Safety Check* section of this guide for testing procedures.

Vehicles with the neutral safety switch built into the column shifter require that the shifter be placed in park in order to remove the keys from the ignition. As a result, it is possible to use the key-in-ignition sense switch to prevent remote starting if the keys are in the ignition. (See *General Motors Trucks, SUVs and Column-Shifting Passenger Cars* and *Pre-1996 Dodge Dakota Pickups with 2.5 Liter Motors* diagrams in this section on how to accomplish this.) The first diagram applies to all General Motors vehicles as of the date of this guide's publication. The second diagram applies to all pre-1996 Dodge Dakota pickup trucks with 2.5 liter motors. This solution has one

side effect: If the customer inserts the key in the ignition with the driver's door open, the remote start system will shut down. If this interface is used, it is important to inform the customer that the driver's door must be closed before inserting the key into the ignition when the remote start is active. This will allow the customer to turn the key on and shut the remote start down by pressing the brake, without the key sense wire shutting down the unit prematurely.

You must also connect the H2/4 BROWN (+) shut-down input to the yellow wire on the relay satellite ribbon cable. This prevents the remote start system from activating if the key is left in the "run" position. You must use diodes to isolate the ignition circuit from the brake switch circuit as shown in the diagram below.

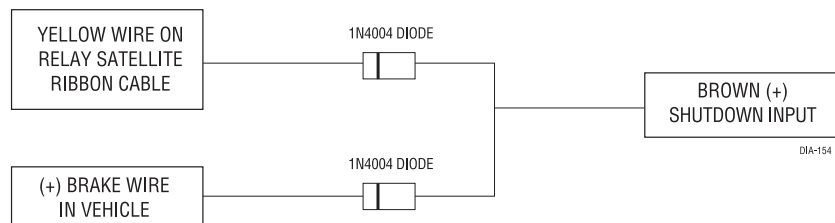

IMPORTANT! Once the interface is complete, attempt to remote start the vehicle with the door closed and the key in the ignition. The vehicle should not start. If it does, re-check the connections.

As of the date of this guide's publication, the following list describes the types of vehicles that are known to have a mechanical neutral safety switch instead of an electrical neutral safety circuit. The model years will vary from vehicle to vehicle. This list will be updated periodically as new information is available; installers are encouraged to call DIRECTED Technical Support at 1-800-753-0800 with updated information.

- Pre-1996 Dodge Dakota pickups with 2.5 liter engines
- GM "B" Platform: Caprice, Impala SS and Roadmaster
- GM "D" Platform: Cadillac Fleetwood and Fleetwood Brougham
- GM "P" Series: Commercial Van
- GM "L/M" Series: Astro, Safari
- GM "C/K" Series: Full-size pickup, Sierra, Suburban, Tahoe, Yukon
- GM "S/T" Series: Blazer, Bravada, Jimmy, pickup, Sonoma
- GM "G" Series: Express, Savannah

general motors trucks, SUVs, and column shifting passenger cars

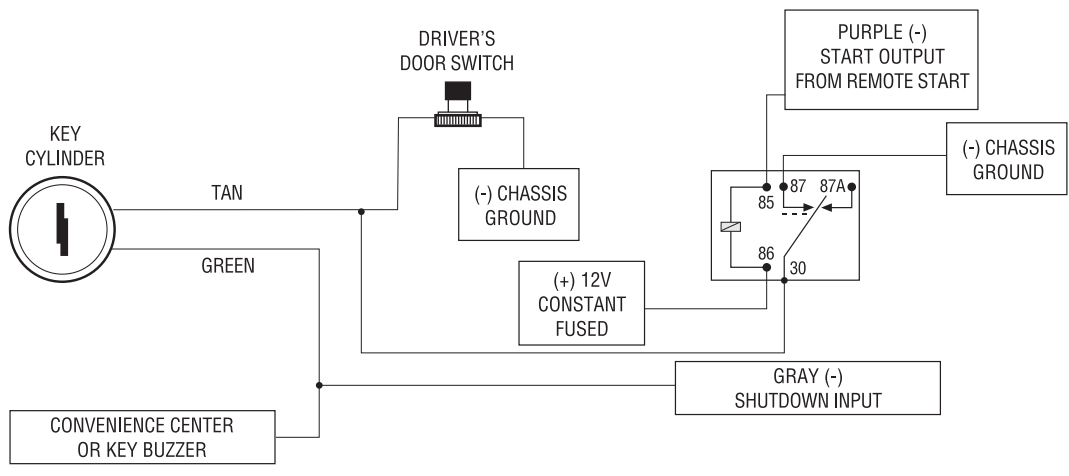

DJA-7

pre-1996 dodge dakota pickups with 2.5 liter motors

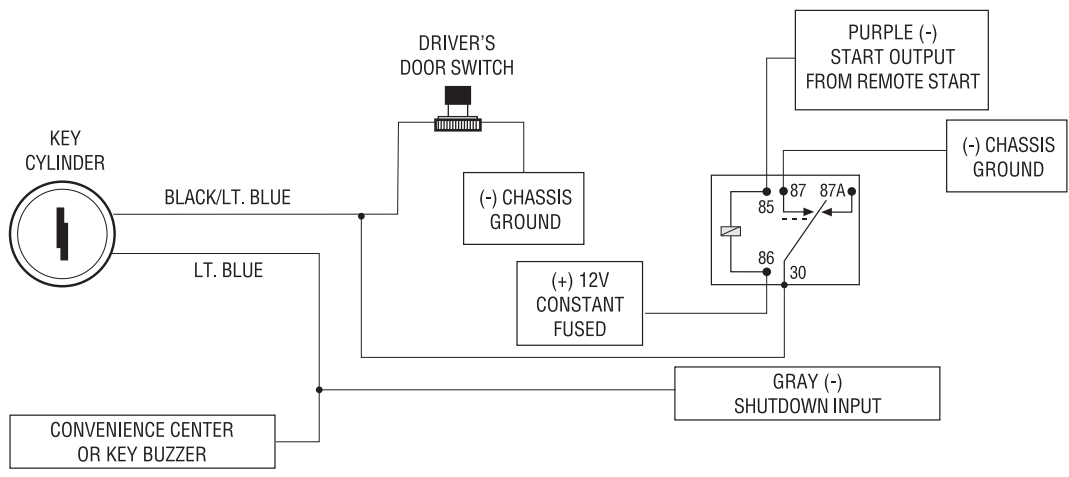

DJA-8

bypassing GM vehicle anti-theft systems (VATS)

Vehicles with the GM VATS (Pass Key) systems have a resistor embedded in the ignition key. If the VATS decoder module does not measure the proper resistance when the vehicle is started, the starter and fuel pump may be disabled for up to ten minutes. The system includes a "VATS pack" of resistors. One will match the resistor in the key.

The VATS wires will be two very light-gauge wires coming out of the steering column. The colors of the wires vary, but they are often contained in orange tubing. Determine the value of the resistor in the key. Then follow the diagram below to bypass VATS during remote start operation. If the BLUE status output has been programmed for factory security re-arm, use the BLUE/BLACK Ignition 2 output to control the relay.

NOTE: When connecting to the VATS wires, it is not important which wire is cut.

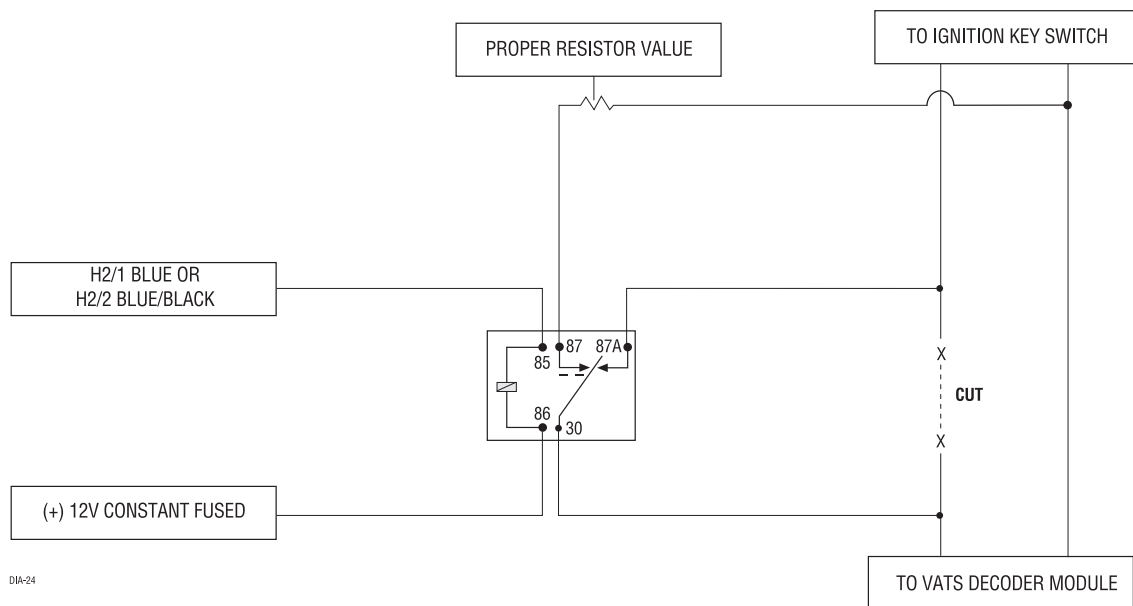

1995 and newer vehicle anti-theft systems (immobilizers)

1995 and newer vehicle anti-theft systems (immobilizers) require a bypass module. The bypass module allows for easy interfacing, while still maintaining the OEM system's integrity.

passlock I and passlock II (PL-1 and PL-2)

The Passlock I and Passlock II systems can be found in the following General Motors vehicles:

- '95 and newer Cavalier and Sunfire
- '96 and newer Achieva, Grand Am, and Skylark
- '97 and newer Intrigue, Malibu, and Cutlass
- '98 and newer trucks, vans, SUVs
- '99 and newer Alero
- 2000 and newer Impala and Saturn

Passlock I and II systems are VATS-evolved. Passlock systems still rely on the R-code to start, but the pellet is no longer placed in the key. The resistor can now be found in the key switch. This allows for a greater number of possible R-codes. In addition, Passlock systems require "seeing" the correct R-code at the correct time. To bypass Passlock I and II, **p/n 555L** or **p/n 555T** is required.

passkey III (PK-3), transponder-based systems

The Passkey III system can be found in the following vehicles:

- '97 and newer Park Avenue
- '98 and newer Cadillac
- '99 and newer U vans, Transport, Montana, and Silhouette
- 2000 and newer Grand Prix, Lesabre, Monte Carlo, Lumina, Bonneville
- 2001 and newer Aurora, Aztek and Rendezvous

Other transponder-based systems include: Acura, BMW, Dodge/Chrysler/Jeep, Ford, Honda, Infinity, Mazda, Mercedes, Mitsubishi, Nissan, Toyota, Volkswagon, and Volvo.

PK-3 and the transponder-based systems use a transponder system that locks out the ignition and fuel system. This transponder system is comprised of two parts. The first part, the transceiver, circles the key switch and is activated when the key is placed in the key switch or turned to the run position. Upon activation, the transceiver

will excite the transponder, which is located (but not visible) in the head of the ignition key. The key transponder will then send a unique code back to the transceiver for evaluation. If the code matches a valid code of the system, the vehicle will be allowed to start. Most of these transponder-based systems can be bypassed using **p/n 555U**. Some may require additional parts from the vehicle manufacturer. Consult your dealer for the applications. For most Ford PATS transponders, **p/n 555F** can be used, except for the following vehicles, which will require **p/n 555U**: '97 and newer Mark VII, and 2000 and newer Taurus/Sable, Contour/Mystique and Focus.

optional anti-grind relay

The anti-grind relay prevents the starter from engaging if the ignition key is accidentally turned to the start position during remote start operation.

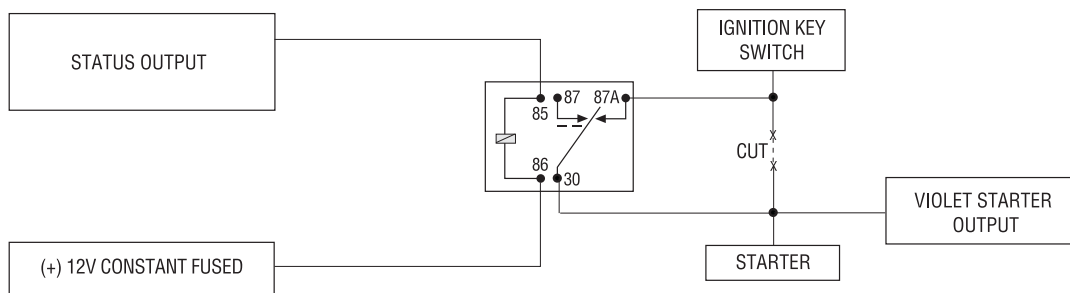

door lock wiring guide

The blue (H1/8) and green (H1/7) lock wires provide 200mA negative pulses that are used to control electric door locks. Most common interfaces are described in this section.

type A: (+) 12V pulses from the switch to the factory relays

The correct wires can usually be found in either kick panel. If you cannot get to the switch, and you find a set of wires that pulse (+)12V alternately on lock and unlock, you must take care to ensure that it is not a Type C direct-wire system.

Here is a test: Cut the wire which pulses (+)12V on lock, and then operate the switch to unlock.

- If all doors unlock, the vehicle uses Type A system.
- If you lose all door lock operation in both directions, you are operating the master switch in a Type C system.
- If you lose all door lock operation of one or more doors, but not all motors stop operating, and other doors still work, you have cut a wire leading directly to one or more motors. You must instead find the actual wires leading to the switch.

Many domestically-made GM vehicles use Type A locks, while almost all domestically-built Fords are Type C (Ford builds almost no Type A systems). Chrysler builds both Type A and Type C, so use caution.

WARNING! Many more GM locks are Type C than in previous years. The full-size pickups (1989-up), many of the S10 Blazers, the Corvette, 1995 Cavalier/Sunfire 1993 - and newer, and Camaro/Firebird all use Type C door locks, and cannot be controlled without a 451M!

To interface two relays, a 451M, or a 453T will be required.

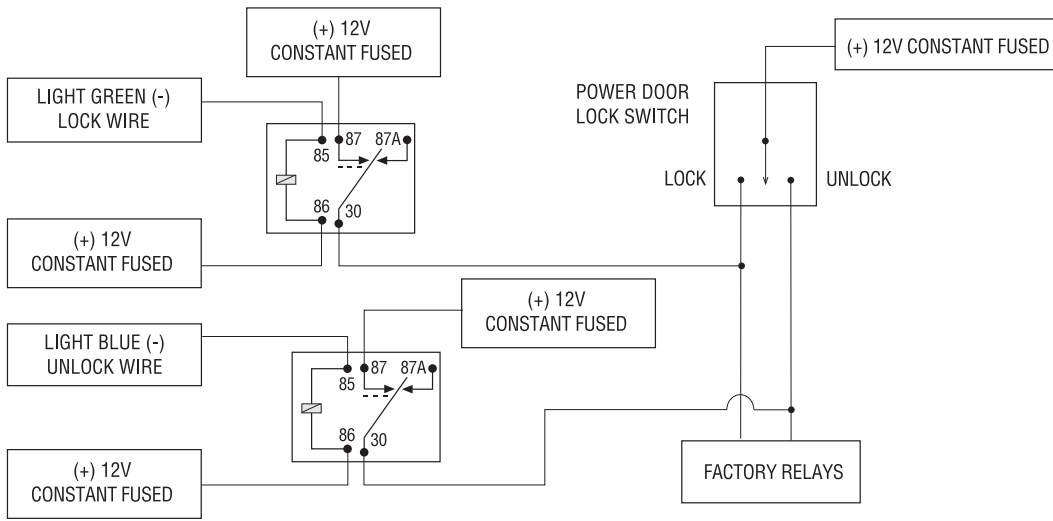

type B: (-) pulses from the switch to the factory relays

This system is common in many Toyotas, Nissans, Hondas, and Saturns, as well as Ford models with keyless entry systems (some other Fords also use Type B).

The switch will have three wires on it, and one wire will test ground all the time. One wire will pulse (-) when the switch locks the doors, and the other wire will pulse (-) when the switch unlocks the doors. This type of system is difficult to mistake for any other type.

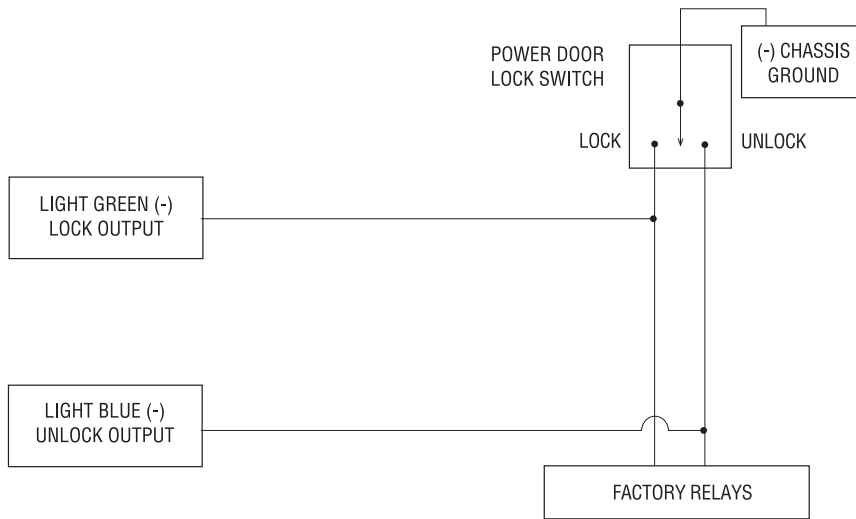

DJA-156

type C: reversing polarity

Interfacing with a reversing polarity system requires either two relays or one 451M (not included).

It is critical to identify the proper wires and locate the master switch to interface properly. Locate wires that show voltage on lock and unlock. Cut one of the suspect wires and check operation of the locks from both switches. If one switch loses operation in both directions and the other switch operates in one direction only, you have located one of the target wires. The switch that lost all operation is the master switch. If one switch works both directions and the other switch works only one direction, you have a Type A system. If both switches still operate, but one or more doors have stopped responding entirely, you have cut a motor lead. Reconnect it and continue to test for another wire. Once both wires have been located and the master switch identified, cut both wires and interface as shown below.

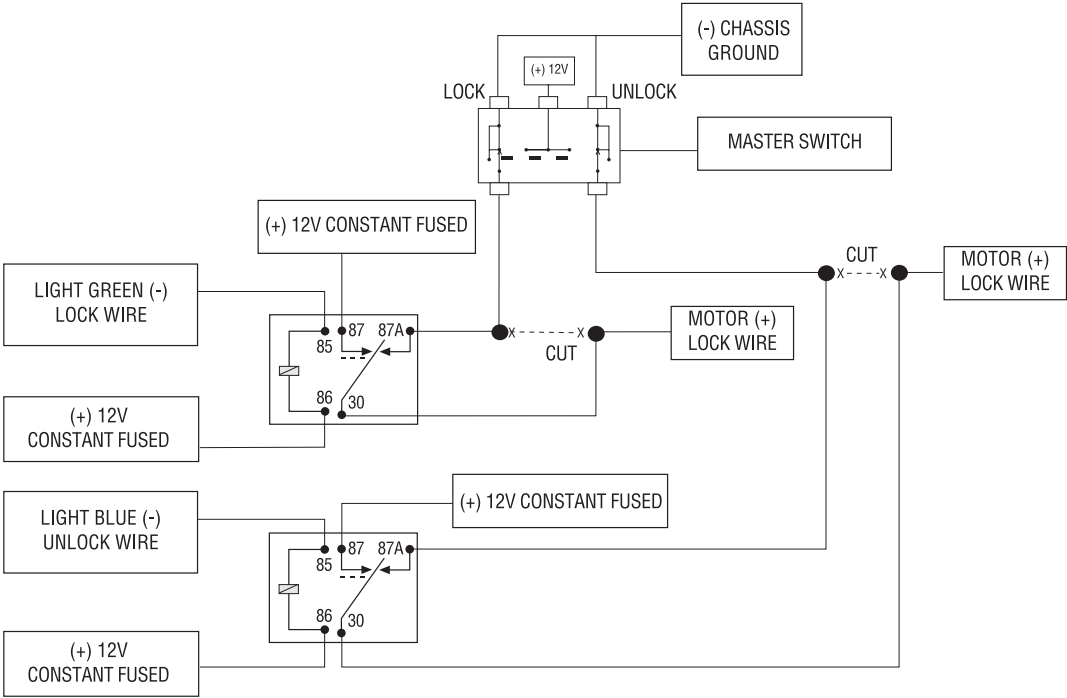

DIA-157

IMPORTANT! If these are not connected properly, you will send (+)12 volts directly to (-) ground, possibly damaging the alarm or the factory switch.

type D: after-market actuators

In order for this system to control one or more after-market actuators, a 451M or two relays (optional) are needed.

Vehicles without factory power door locks require the installation of one actuator per door. This requires mounting the door lock actuator inside the door. Other vehicles may only require one actuator installed in the driver's door if all door locks are operated when the driver's lock is used. This type of installation is required to operate factory lock systems in Volvo (except 850), SAAB, and most Mazda, Isuzu and Subaru models.

The fuse used on 12-volt inputs should be 7.5A per motor installed in the vehicle.

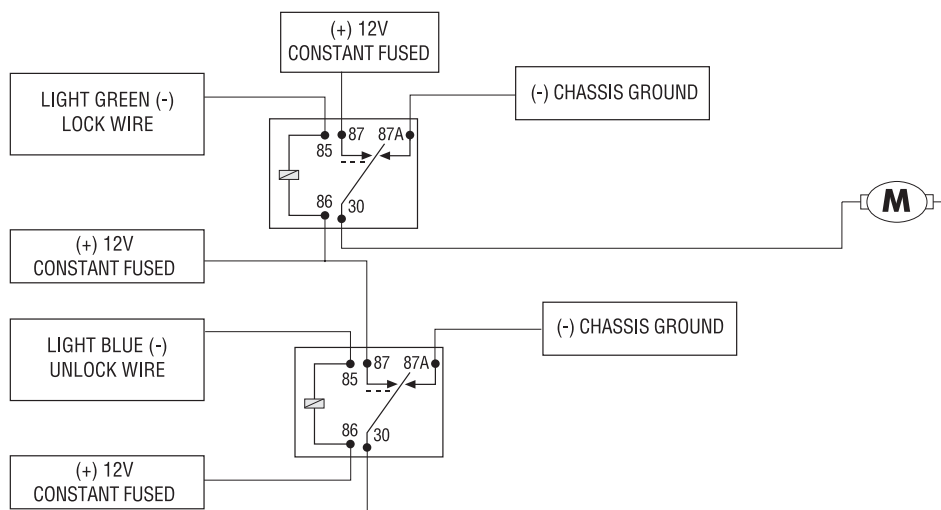

IMPORTANT! Do not connect the outputs of the alarm directly to the actuator!

type E: mercedes-benz and audi (1985 & newer)

This type of door locking system is controlled by an electrically activated vacuum pump; however, the 551R is not capable of controlling Type E locks.

type F: one-wire system

This system usually requires a negative pulse to unlock, and cutting the wire to lock the door. In some vehicles, these are reversed. This system is found in late-model Nissan Sentras, some Nissan 240SX, and Nissan 300ZX 1992 and later. It is also found in some Mazda MPV and some Mitsubishi models.

One relay (optional) is used to interface to this type of system as follows:

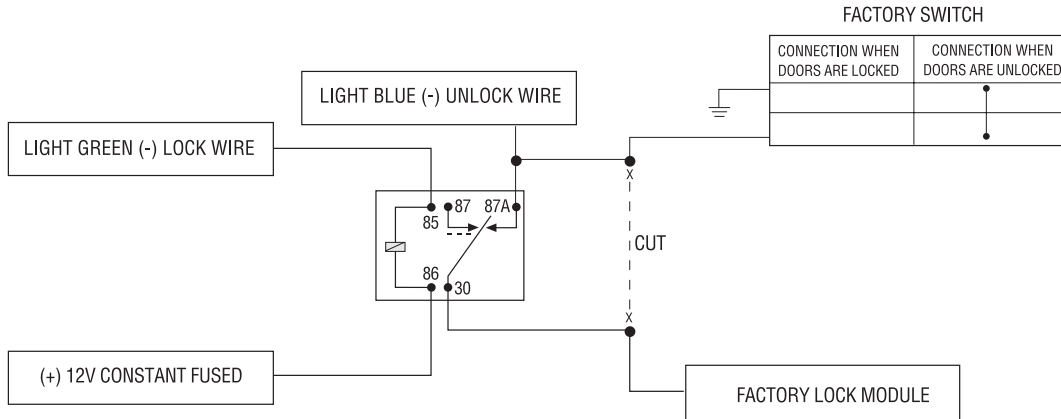

type G: positive (+) multiplex

This system is most commonly found in Ford, Mazda, Chrysler and GM vehicles. The door lock switch or door key cylinder may contain either one or two resistors. When interfacing with this type of door lock system, two relays or a Directed Electronics 451M must be used. (See diagram below.)

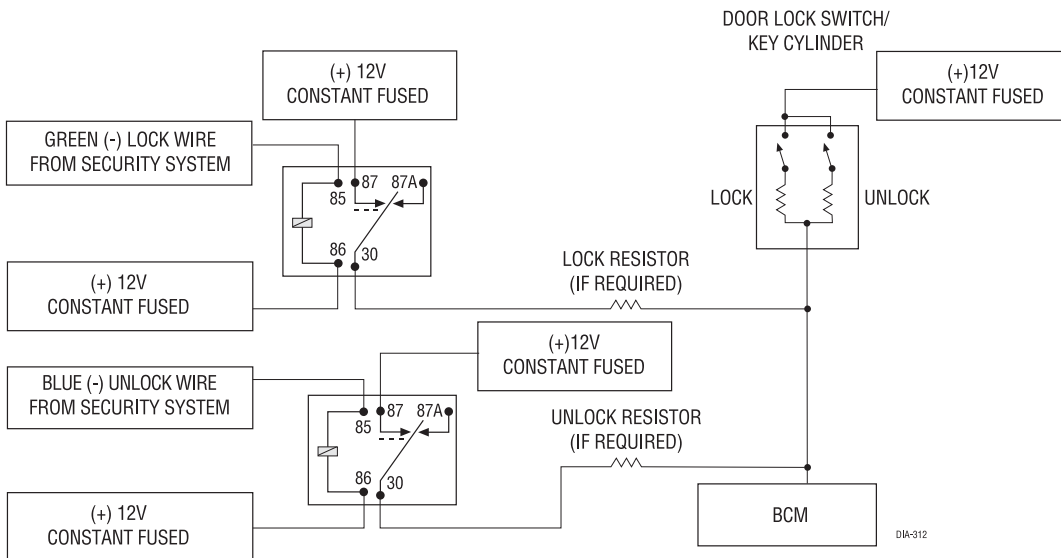

single-resistor type

If one resistor is used in the door lock switch/key cylinder, the wire will pulse (+)12V in one direction and less than (+)12V when operated in the opposite direction.

two-resistor type

If two resistors are used in the factory door lock switch/key cylinder, the switch/key cylinder will read less than (+)12V in both directions.

determining the proper resistor values

To determine the resistor values, the door lock switch/key cylinder must be isolated from the factory door lock system. For all testing, use a calibrated digital multimeter that is set to ohms.

1. Cut the output wire from the door lock switch/key cylinder in half.
2. Test with the meter from the switch side of the cut door lock switch/key cylinder wire to a reliable constant (+)12V source. Some good constant (+)12V references are the power input source to the door lock switch/key cylinder, the ignition switch power wire, or the (+) terminal of the battery.
3. Operate the door lock switch/key cylinder in both directions to determine the resistor values. If the multi-meter displays zero resistance in one direction, no resistor is needed for that direction.
4. Once the resistor value(s) is determined, refer to the wiring diagram for proper wiring.

type H: negative (-) multiplex

The system is most commonly found in Ford, Mazda, Chrysler and GM vehicles. The door lock switch or door key cylinder may contain either one or two resistors.

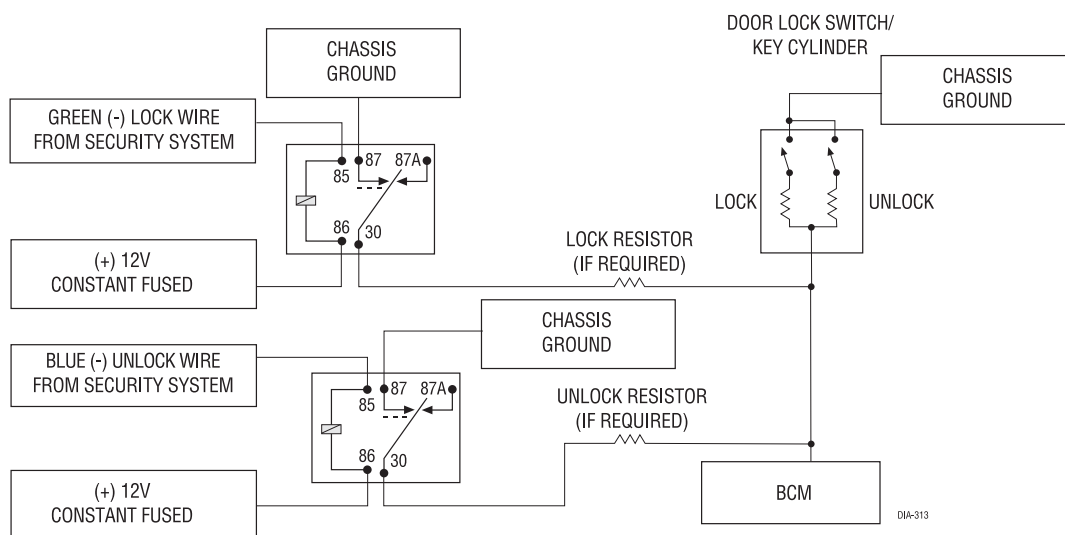

single-resistor type

If one resistor is used in the door lock switch/key cylinder, the wire will pulse ground in one direction and resistance to ground when operated in the opposite direction.

two-resistor type

If two resistors are used in the factory door lock switch/key cylinder, the door lock switch/key cylinder will read resistance to ground in both directions.

determining the proper resistor values

To determine the resistor values, the door lock switch/key cylinder must be isolated from the factory door lock system. For all testing, use a calibrated digital multimeter that is set to ohms.

1. Cut the output wire from the door lock switch/key cylinder in half.
2. Test with the meter from the switch side of the cut door lock switch/key cylinder wire to a reliable ground source. Some good ground references are the ground input source to the door lock switch/key cylinder or the battery ground.
3. Operate the door lock switch/key cylinder in both directions to determine the resistor values. If the multi-meter displays zero resistance in one direction, no resistor is needed for that direction.
4. Once the resistor value(s) is determined, refer to the wiring diagram for proper wiring.

programming jumpers

TACH THRESHOLD OFF (DEFAULT) ●●
TACH THRESHOLD ON ●●
(-) LIGHT FLASH OUTPUT ●●
(+) LIGHT FLASH OUTPUT (DEFAULT) ●●

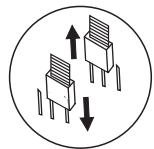

TO CHANGE
JUMPER
SETTINGS

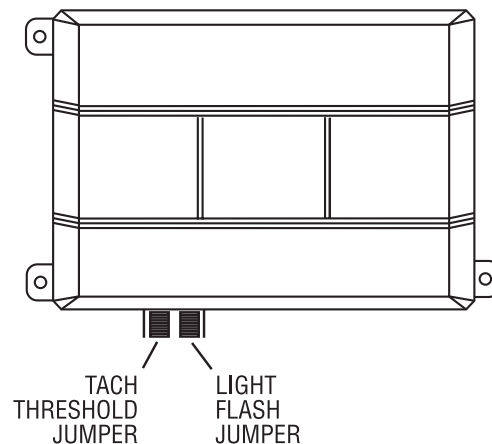

light flash (+)/(-)

This jumper is used to determine the light flash output polarity. In the (+) position, the on-board relay is enabled and the unit will output (+)12V on the WHITE wire, H1/2. In the (-) position, the on-board relay is disabled. The WHITE wire, H1/2, will supply a 200mA (-) output suitable for driving factory parking light relays.

NOTE: For parking light circuits that draw 10 amps or more, the internal jumper must be switched to a (-) light flash output. **P/N 8617** or a standard automotive SPDT relay must be used on the H1/2 light flash output harness wire.

tach threshold on/off

In most cases, this jumper can be left in the OFF position. Some new vehicles use less than 12 volts in their ignition systems. The unit may have trouble learning the tach signal in these vehicles. Changing the jumper to the ON setting changes the trigger threshold of the digital tach circuit so it will work properly with these vehicles. The vehicles affected include many newer Dodge/Chrysler/Plymouth vehicles, such as the Neon, Cirrus, Stratus, Breeze and LH-based vehicles.

plug-in program switch

The Program switch plugs into the blue two-pin connector.

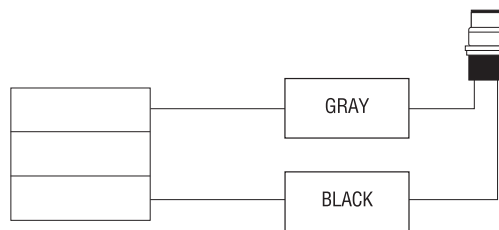

DIA-42

transmitter/receiver learn routine

The system comes with one transmitter that has been taught to the receiver. The receiver can store up to 4 different transmitter codes in memory. Use the following learn routine to add transmitters to the system or to change button assignments if desired.

The Program switch, plugged into the blue port, is used for programming. There is a basic sequence of steps to remember whenever programming this unit: Key, Choose, Transmit and Release.



1. **Key.** Turn the ignition to the ON position.



2. **Choose.** Within 10 seconds, press and release the Program switch the number of times corresponding to the desired channel listed below. Once you have selected the channel, press the switch once more and **HOLD** it. The LED will flash to confirm the selected channel. Do not release the Program switch.

auto learn transmitter configuration



button onelock/unlock



button twoChannel 2



button threeRemote Start



buttons one and twotimer mode



button one and threeturbo start/short run

CHANNEL NUMBER	FUNCTION
1	Auto-Learn
2	Lock/Unlock
3	Channel 2 output
4	Remote Start
5	Turbo/Short Run
6	Timer Mode
7	Delete all Transmitters



3. **Transmit.** While **HOLDING** the Program switch, press the button on the transmitter that you would like to control the selected receiver channel.



4. **Release.** Once the code is learned, the Program switch can be released.

You can advance from programming one channel to another by releasing the Program switch and tapping it to advance steps and then holding it. For instance: You have programmed Channel One and you want to program Channel Two. Release the Program switch. Press it one time and release it to advance from Channel One to Channel Two. Now, press and **HOLD** the Program switch. The LED will flash two times. As before, do not release it.

If you want to program Channel Three after programming Channel One, release the Program switch, press it twice and release it to advance to Channel Three. Then press it once more and **HOLD** it. The LED will flash three times to confirm it is ready to receive the code from the transmitter.

Learn Routine will be exited if:

- Ignition is turned off.
- Program switch is pressed too many times.
- More than 25 seconds elapses between programming steps.

tach learning

to learn the tach signal



1. Start the vehicle with the key.



2. Within 5 seconds, press and **HOLD** the Program switch.



3. The LED will light constant when the tach signal is learned.



4. Release the Program switch.

operating settings learn routine

The System Features Learn Routine dictates how the unit operates. The programmable operating settings of this unit can be changed whenever necessary through the computer-based Learn Routine. The Program push-button switch, plugged into the blue port, is used together with a programmed transmitter to change the settings. It is possible to access and change any of the feature settings using the Program switch. To program settings, remember: Key, Choose, Transmit and Release.

To program the learn routine:



1. **Key.** Turn the ignition on and then back off.



2. **Choose.** Within 10 seconds, press and release the Program switch the number of times corresponding to the feature number you want to program. (See *Features Menu* section.)

Once the Program switch has been pressed and released the desired number of times, press it once more and **HOLD** it. After a second, the LED will flash to indicate which feature you have accessed. For example, groups of eight flashes would indicate access to the status output feature (Feature 8).



3. **Transmit.** The transmitter is used to select the desired setting. As shipped, the unit is configured to the LED ON settings. These are called the default settings. Pressing Channel One (usually Button I) will set it to the LED ON setting. The LED will light solid (stop flashing) to indicate the setting. Pressing Channel 2 (usually Button II) will change the setting to the LED OFF setting. The LED will go out indicating the change.



4. **Release.** The Program switch can now be released.

You can advance from feature to feature by pressing and releasing the Program switch the number of times necessary to get from the feature you just programmed to the feature you wish to access. For example, if you just programmed the run time (Feature 3) and you next want to program parking lights (Feature 4) to constant, release the Program switch. Press and release it once to advance from Feature 3 to Feature 4. Then press it once more and **HOLD** it. The LED will flash in groups of 4 to confirm that you have accessed Feature 4.

The learn routine will be exited if any of the following occurs:

- The ignition is turned on.
- The Program switch is pressed too many times.
- More than 25 seconds elapses between programming steps.

features menu

The factory default settings are indicated in **bold** text in the table below.

FEATURE NUMBER	DEFAULT - LED ON SETTING (PRESS CHANNEL 1)	LED OFF SETTING (PRESS CHANNEL 2)
1	Engine checking on	Engine checking off
2	Tachometer checking type	Voltage checking type
3	12 minutes run time (1)*	24 minutes (2)*, 60 minutes (3) run time
4	Flashing parking light output	Constant parking light output
5	Cranking time 0.6 sec. (1)	Cranking time 0.8 (2), 1.0 (3), 1.2 (4), 1.4 (5), 1.6 (6), 1.8 (7), 2.0 (8), 4.0 (9) sec.
6	Voltage check high level	Voltage check low level
7	Short Run (turbo timer): 1 min	Short Run (turbo timer) 3, 5, 10 minutes
8	Activation pulse: 1 (1)	Activation pulses: 2 (2), 3 (3)
9	Ignition/accessory output: Ignition	Ignition/accessory output: Accessory
10	Accessory state during wait to start: OFF	Accessory state during wait to start: ON
11	2nd status output: Normal	Rear defogger latched (1)/pulsed (2)
12	Unlock output 1 pulse	Unlock output 2 pulses
13	Ignition lock ON	Ignition lock OFF
14	Ignition unlock ON	Ignition unlock OFF

**NOTE: The number in parentheses indicate the number of times the LED will flash*

feature descriptions

1 ENGINE CHECK ON/OFF: In the default setting the remote start will monitor either the vehicle's tach wire or voltage depending on the programming of Feature 2. If programmed off, the vehicle will crank for the programmed crank time (Feature 5) and will not verify with tach or voltage that the vehicle is running. In the off setting, if the vehicle fails to start, the ignition can stay on for the entire run duration. Using tach or voltage check is always recommended if possible.

2 TACH WIRE SENSE/VOLTAGE SENSE: If the tachometer signal wire is used, this feature must be left in the default (tach wire connected) setting. If programmed to the voltage sense setting, the unit will crank the starter for a preset time that can be programmed in Feature 5. Once the starter has been engaged, the system will check the voltage level to verify the engine is running. The threshold for the voltage level test can be programmed in Feature 6. When using voltage sense mode, connection of the H2/5 VIOLET/ WHITE tachometer input is not necessary.

3 RUN TIME 12/24/60 MINUTES: This feature controls how long the engine will run before it “times out” and shuts down. Programmed to the default setting the engine will run for 12 minutes. If the 24 or 60 minute run time is desired, change this feature to the two or three flash setting.

4 PARKING LIGHTS FLASHING/CONSTANT: In the default setting, the unit will flash the vehicle’s parking lights while remote started. The constant setting will turn the parking lights on solidly for the entire run duration.

5 CRANK TIME 0.6/0.8/1.0/1.2/1.4/1.6/1.8/2.0/4.0: If Feature 2 is programmed to the voltage sense setting, the crank time must be set to the appropriate duration. The default setting is 0.6 second. If a different crank time is desired, select Feature 5 and (while pressing the Program switch) press the Channel Two button to advance through the LED Off settings. The unit will flash the LED to indicate which time is selected. Once the 4.0 second setting is reached the next press of the Channel Two button will reset the system to the shortest setting.

6 VOLTAGE CHECK LEVEL HIGH/LOW: This feature only functions when Feature 2 is programmed to voltage sense. Some vehicles have many accessories, which are turned on when remote started. In these vehicles, the variation of voltage between the engine off and the vehicle running is very slight and the remote start unit may “think” the vehicle has not started. This can cause the remote start to shut down after the vehicle has been started. If this is the case, program this feature to the LOW position.

7 SHORT RUN (TURBO TIMER): When the  and **AUX** buttons on the transmitter are pressed simultaneously while the engine is running, the vehicle will continue to run for the short run time. The factory default is 1 minute.

8 ACTIVATION PULSE COUNT: This feature allows the number of pulses to activate the remote start feature to be changed from 1, 2, or 3 pulses. The pulse count programmed to start the vehicle will also be the same required to shut down the remote start.

9 2nd IGNITION/ACCESSORY OUTPUT: This will allow the PINK/WHITE to be used as a 2nd ignition or a 2nd accessory.

10 ACCESSORY STATE DURING WAIT-TO-START: This will allow the programming of the accessory wire during the wait-to-start period of a diesel motor. When ON the accessory comes on when the wait-to-start output is activated and stays on, dropping out during crank and returning once the car has started. When OFF the accessory will activate as a normal accessory.

11 2nd STATUS OUTPUT: If programmed to status mode, this output will turn on when the remote start is activated. In defogger mode the output can be programmed to a latched or a pulsed output. When programmed to the latched output the status will only stay active for 10 minutes.

12 UNLOCK OUTPUT: This will program the unlock output to one or two pulses.

13 IGNITION CONTROLLED LOCK: When programmed ON the doors will lock when the key is on and all doors are closed.

14. IGNITION CONTROLLED UNLOCK: When programmed ON the doors will unlock automatically when the key is turned off.

shutdown diagnostics

The unit has the ability to report the cause of the last shutdown of the remote start system. To enter diagnostic mode:



1. Turn the ignition off.



2. Press and **HOLD** the Program switch.



3. Turn the ignition on and then off.



4. Release the Program switch.

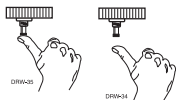



5. Press and release the Program switch.

The LED will now report the last system shutdown by flashing for one minute in the following grouped patterns:

LED FLASHES	SHUTDOWN MODE
One	System timed out
Two	Over-rev shutdown
Three	Low or no RPM
Four	Transmitter Shutdown (or optional push-button)
Six	(+/-) Shutdown
Seven	(-) Neutral safety shutdown (H2/6 BLACK/WHITE)
Eight	Wait-to-start timed out

The LED will stop flashing when the ignition is turned on.

timer mode

By pressing the remote  /  and **AUX** buttons simultaneously the parking lights will flash 4 times and then start the vehicle and run for the set duration. The remote start can be shut off by the transmitter by pressing the remote start button  and remain in timer mode, but if any other shut down zones or the ignition becomes active the timer mode will cancel.

1. Press Timer mode buttons.
2. The vehicle will confirm with 4 parking light flashes.
3. A 1-second delay will start.
4. The system will start the car and will run for the specified duration, unless shut down by the remote start button  (or the +/- input).
5. The system will start every 3 hours until canceled by the brake, hood, or neutral safety shut-down wires (a maximum of 6 times).

IMPORTANT! *Timer Mode should be used only in open areas. Never start and run the vehicle in an enclosed space such as a garage or carport.*

safety check

Before vehicle reassembly, the remote system must be checked to ensure safe and trouble-free operation. The following test procedure must be used to verify proper installation and operation of the system. The installation must be completed before testing, including connection to the brake switch and hood switch.

1. Test the BRAKE shutdown circuit: With the vehicle in Park (P), activate the remote start system. Once the engine is running, press the brake pedal. The engine should shut down immediately. If the engine continues to run, check the brake circuit connection.
2. Test the HOOD PIN shutdown circuit: With the vehicle in Park (P), open the hood. Activate the remote start system. The vehicle should not start. If the starter engages, check your hood pin and connections.

NOTE: *If programmed for Diesel Mode, the system will turn on the ignition, but the starter should not engage with the hood open.*

3. Test the NEUTRAL SAFETY shutdown circuit:

IMPORTANT! *Make sure there is adequate clearance to the front and rear of the vehicle before attempting this test.*

- a. Make sure the hood is closed and no other shutdown circuits are active.
- b. Set the emergency brake.
- c. Turn the ignition key to the run position but do not start the engine.
- d. Put the vehicle in Drive (D).
- e. Put your foot over the brake pedal but do not press down on it. Be ready to step on the brake to shut-down the remote start system.
- f. Activate the remote start system.
 - If the starter engages, immediately step on the brake to shut down the system. If it does engage, recheck the neutral safety input connection. The vehicle may use a mechanical neutral safety switch. (See H2/6 BLACK/WHITE neutral safety switch input in *Remote Start Harness Wire Connection Guide* section of this guide.)
 - If the starter does not engage, the test is complete.

Once the system passes all three tests, the vehicle can be re-assembled and delivered. Do not the use the remote start system or finalize the installation if it fails any of the safety check tests.

troubleshooting

■ The ignition comes on, but the starter will not crank.

Does it start with the key in the ignition? If so, does the vehicle have a VATS Pass-Key system?

Will it start with the brake pedal depressed? (Make sure to disconnect the brake shutdown when performing this test.) If so, it may have a brake/starter interlock.

Is the correct starter wire being energized? Check by energizing it yourself with a fused test lead.

■ The starter cranks for six seconds but does not start.

Either the wrong ignition wire is being energized, the system's ignition and accessory wires have been connected backwards, or the vehicle has two ignition circuits. Try activating the unit with the ignition key in the "run" position. If the vehicle then runs normally, retest your ignition system.

■ The starter continues to crank even though the engine has started.

Has the tach wire been learned? See the *Tach Learning* section of this guide.

Is the tach wire receiving the correct information? Either the wrong tach wire has been used, or a bad connection exists.

■ The climate control system does not work while the unit is operating the vehicle.

Either the wrong accessory wire is being energized or more than one ignition or accessory wire must be energized in order to operate the climate control system.

■ The remote start will not activate.

1. Check harnesses and connections. Make sure the harnesses are fully plugged into the remote start module. Make sure there are good connections to the vehicle wiring.
2. Check voltage and fuses. Use a meter and check for voltage between the red wire in the 5 pin ribbon harness and the black ground wire. If you have less than battery voltage, check the 3A and both 30A fuses on the relay satellite. Also make sure that the ground wire is going to a chassis ground and not to something under the dash.
3. Check diagnostics. The diagnostics will tell you which shutdown is active or not connected.

■ The remote start will activate but the starter never engages.

1. Check for voltage on the purple starter wire two seconds after the remote start becomes active. If there is voltage present, skip to Step 4. If there is not voltage present, advance to Step 2.
2. Check the 30A fuses.
3. Check diagnostics. If the gray/black wire is detecting ground upon activation, the starter will not crank.
4. Make sure the purple starter wire is connected on the starter side of the optional starter kill relay.

5. Does the vehicle have an immobilizer? Some immobilizer systems will not allow the vehicle to crank if active.
6. Check connections. The two red heavy gauge input wires on the relay satellite should have solid connections. "T-taps", or "scotch locks" are not recommended for any high current heavy gauge wiring. Also, if the vehicle has more than one 12-volt input wire, then connect one red wire to each.

■ **The vehicle starts, but immediately dies.**

1. Does the vehicle have an immobilizer? The vehicle's immobilizer will cut the fuel and/or spark during unauthorized starting attempts.
2. Is the remote start programmed for voltage sense? If so, the start time may not be set high enough, or you may have to adjust the voltage threshold in programming. Voltage sense will not work on some vehicles.
3. Check diagnostics. Sometimes a shutdown will become active during cranking or just after cranking.

■ **The vehicle starts, but the starter keeps running.**

1. Is the system programmed for engine checking off or voltage sense? When programmed for either of these features, the engine cranks for the preprogrammed crank time regardless of how long it takes to start the vehicle to actually start. Adjust to a lower cranking time.
2. Was the Tach Learn successful? The LED must light solidly and brightly to indicate a successful learn.
3. Make sure that there is a tach signal right at the purple/white tach input wire of the remote start. If not, recheck the connection to the vehicle's tach wire and make sure the wire is not broken or shorted to ground leading to the remote start.

■ **The vehicle will start and run only for about 10 seconds.**

1. Is the remote start programmed for voltage sense? Try programming the unit for low voltage reference. If this does not work, a tach wire should be used.
2. Check diagnostics.

■ **Diesel vehicle does not wait to start.**

1. Is the GRAY/BLACK wire connected to the wait-to-start wire of the vehicle?
2. Check the polarity of the wait-to-start wire. (See the *Finding the Wait-to-Start Bulb Wire For Diesels* section of this guide.)
3. If wiring a negative wait-to-start bulb, make sure that a diode has been placed in line on the factory wire between the vehicle's ECM and the wait-to-start bulb. (See wiring description for the *H1/6 GRAY/BLACK (-) Diesel Wait-To-Start Bulb Input* of the *Primary Harness Wire Connection Guide*.)

wiring quick reference guide

