

Merlin[®]

3000
installation guide

Bitwriter®, Code Hopping®, Directed®, Doubleguard®, ESP®, FailSafe®, Learn Routine™, Merlin®, Nite-Lite®, Nuisance Prevention®, NPC®, Revenger®, Silent Mode™, Soft Chirp®, Stinger®, Valet®, Vehicle Recovery System™, VRS™, and Warn Away® are all Trademarks or Registered Trademarks of Directed Electronics, Vista, California.

contents

what is included	3	to enter Valet mode	18
transmitter configurations	3	to exit Valet mode	18
transmitter functions	4	system features programming . . .19	
standard configuration for		programming instructions	19
in-key 2-button transmitter	4	user selectable features	21
standard configuration for		user selectable features	
3-button transmitter	4	descriptions - column one	21
installation	5	user selectable features	
control module	5	descriptions - column two	22
protection switch	6	user selectable features	
LED status indicator	7	descriptions - column three	23
valet switch	8	installer selectable features	24
primary harness wire		installer selectable features	
connection guide	9	descriptions - column one	25
primary harness wiring diagram	9	installer selectable features	
primary harness wiring guide	10	descriptions - column two	26
in-key 2-button transmitter—		installer selectable features	
key blade installation	14	descriptions - column three	26
tilt sensor	15	programming notes	27
arming/disarming diagnostics . . .16		rapid resume logic	29
arming	16	remote control sensor disable . . .29	
disarming	16	adjusting the tilt sensor	29
system status chirps	16	auto-immobilization feature . . .29	
high security disarm	17	auto-immobilization sequence	29
long term event history	17	troubleshooting and	
table of zones	17	system testing	30
valet mode	18	wiring quick reference guide . . .33	
		notes	35

what is included

- One control module/siren, with built-in Tilt sensor and 24-pin main wiring harness
- One hardware pack
- One Mini-Blue status LED
- One 2-button coded Valet switch
- One in-key 2-button transmitter
- One 3-button transmitter
- Two Merlin decals
- One Owner's Guide
- Warranty Card

transmitter configurations

The Merlin 3000 system comes provided with an in-key 2-button remote control (replacement p/n-482T) and a 3-button remote control (replacement p/n-473B). Two additional remote controls can be added.

IN-KEY 2-BUTTON REMOTE CONTROL

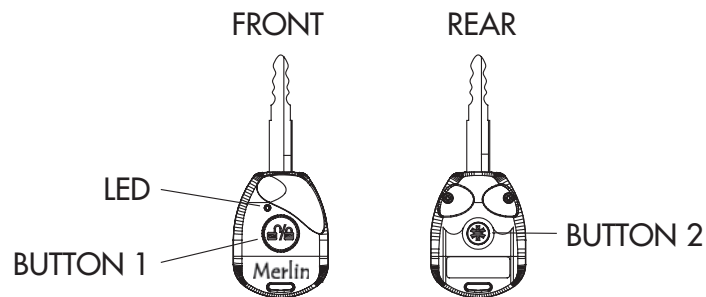

3-BUTTON REMOTE CONTROL

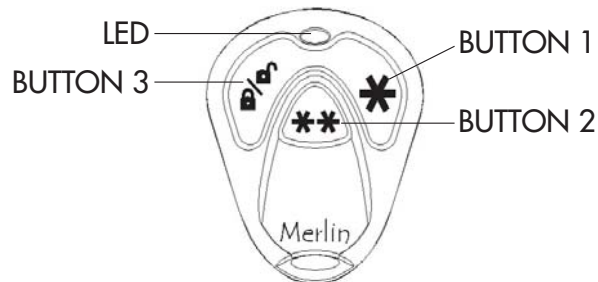

transmitter functions

This system uses computer-based code learning to learn the transmitter buttons. This makes it possible to assign any transmitter button to any system function. The transmitter initially comes programmed with standard configuration, but may also be customized by an authorized dealer. The buttons in all of the instructions in this manual correspond to a standard configuration transmitter.

standard configuration for in-key 2-button transmitter

 Button

The arming, disarming, and panic functions are controlled by this button.

 Button

Controls auxiliary channel output.

 and  Buttons

Disables the on-board control module tilt sensor and any optionally installed sensors.

standard configuration for 3-button transmitter

 Button

The arming, disarming, and panic functions are controlled by this button.

 Button

Controls auxiliary channel output.

 Button

Silent arm and disarm is controlled by this button.

 and  Buttons

Disables the on-board control module tilt sensor and any optionally installed sensors.

 and  Buttons

Remotely enters or exits Valet.

installation

control module

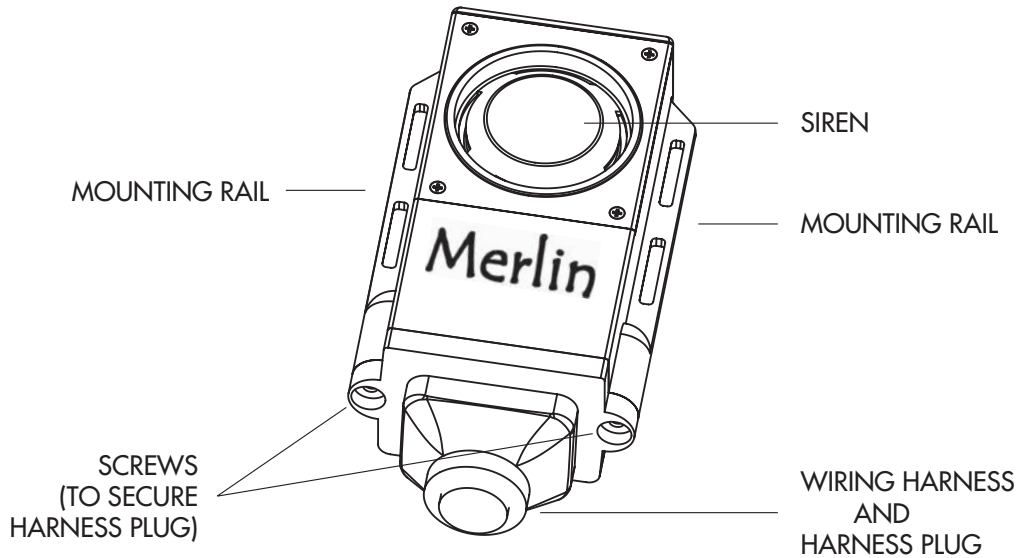

***IMPORTANT:** The control unit **must** be installed as far away as possible from the engine. Under no circumstances should the unit be installed close to hot or moving parts.*

Before commencing with the installation, carefully plan the location of the main control unit and normally closed protection switch.

The control unit should be located in a protected position. Unauthorized access to the control unit should cause the alarm to trigger. Care should also be taken to install the unit where it is most protected from water ingress.

Secure the unit using the supplied hardware options -

- Cable ties

- Screws

- Bolts, spacers and wellnuts

Securing the unit using the supplied wellnuts is the most preferable option as the rubber mounts will enable the unit to move slightly. This will put the unit under the least stress from vibration.

protection switch

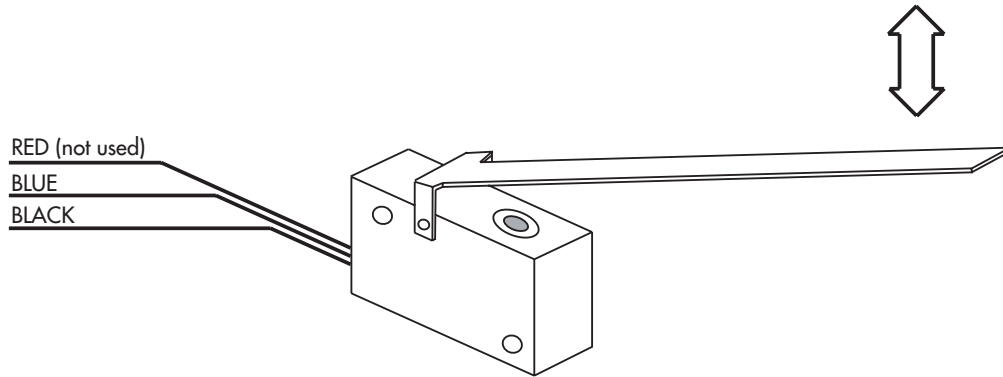

The long lever switch should be installed in a position that requires a part of the motorcycle to be removed to gain access to the control unit. Examples of this are fuel tank, seat, side panel, etc. Once the security system is armed removing this part of the motorcycle should trigger the alarm.

The switch's Black and Blue wires should be connected to the two Grey wires in the main harness of the Merlin 3000 (H1 and H24). It does not matter which way round the wires are connected. This circuit is closed when the alarm is armed which means the alarm will sound if either wire is cut when the system is armed. If not used, the two gray alarm wires must be connected together.

LED status indicator

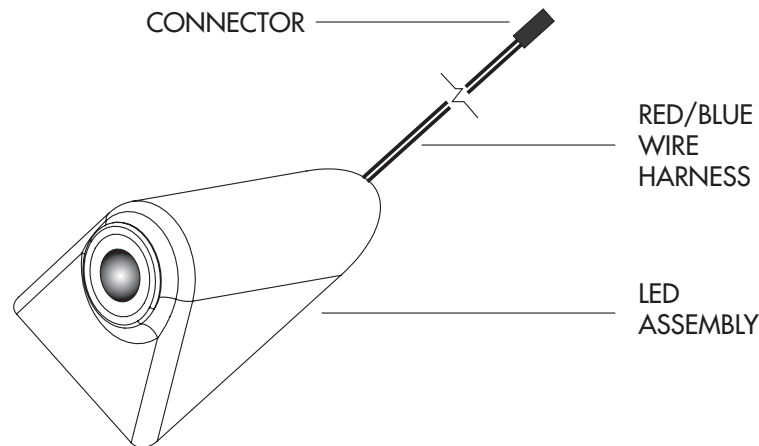

1. Select a prominent location on the motorcycle that is highly visible from all directions. Discuss placement with the owner.
2. There are two mounting methods for the LED status indicator. Flush mounting in a 4.5mm (no. 15 drill - 0.1800 in.) sized hole or surface mounting using the supplied bezel (see assembly above).
3. Verify there is adequate space to accommodate the LED and adequate routing for the length of the LED wire harness.
4. Clean and dry the surface area where the LED is to be mounted.
5. For surface mounting remove the adhesive tape and press the LED assembly onto the mounting area.
6. Once mounted insert the LED red and blue wires into the male black connector in the hardware pack. When connected to the LED female connector in the main harness the wires should match up, red to red and blue to blue. Mate the BLACK mini-connector from LED to the BLACK mini-connector with the RED and BLUE wires coming from the control unit.

valet switch

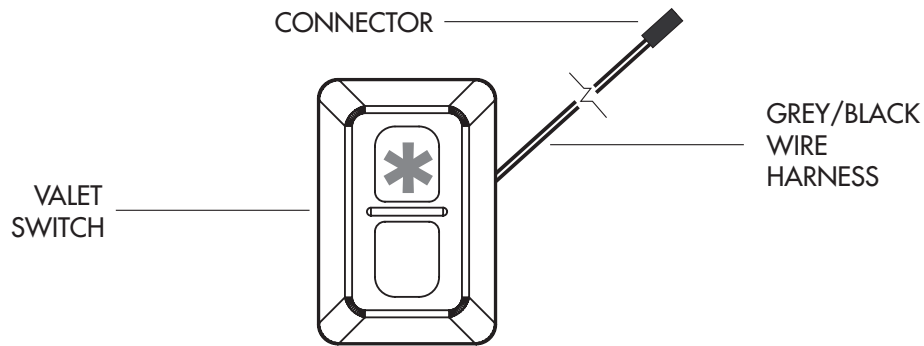

1. The Valet/program switch needs to be placed in a position where the customer has easy access for programming and override but where it will not get wet. Examples are under the seat or inside a compartment the owner can get to. Discuss placement of the switch with the vehicle owner and avoid placing the switch where it can be pressed accidentally.
2. If necessary check for rear clearance and then drill a 9/32-inch hole for mounting the switch.
3. Clean and dry the surface area where the switch is to be mounted.
4. Mount the switch using the supplied adhesive tape.
5. Mate the switch's BLACK connector to the BLACK connector with the GREY and BLACK wires from the control unit.

primary harness wire connection guide

primary harness wiring diagram

H1	BLACK	Ground 1
	GREY	Ground for N/C input
H2	BLACK	Ground 2
H3	RED/WHITE	(-) Auxiliary Channel Output
H4	ORANGE	(-) Armed Signal Output (GWA)
H5	YELLOW/WHITE	Aux Siren/Horn Output (-) Pulsed/Latched
H6	BLACK	Antenna
H7	BLUE	(-) LED Output
H8	BLACK	Valet Switch—Low Current Ground
	BLACK	MUX—Low Current Ground
H9	GREY	Valet Switch Input
H10	RED	Low Current 12V—LED
	RED	Low Current 12V—MUX
H11	BLUE	MUX 1 Data
H12	GREEN	MUX 2 Data
H13	BLACK	(+) 12V Input
H14	WHITE	Indicator Output—Left
H15	WHITE/RED	Indicator Input (+) or (-)
H16	WHITE	Indicator Output—Right
H17	YELLOW	Ignition Input (+) 12V
H18	BLACK	Starter Switch Side
H19	BLACK	Starter—Starter Side
H20	BLACK	Immobilizer—Common
H21	BLACK	Immobilizer—Normally Open
H22	BLACK	Immobilizer—Normally Closed
H23	BLUE	N/O-N/C Programmable Input
H24	GREY	N/C Protection Switch Input

NOTE: The H1, H8, and H10 pins have two wires for each pin.

The BLACK wires in the harness are identified with labels describing their function (see table below). These labels are to be removed after installation.

Pin	Label Description
1	GROUND
2	GROUND
13	(+)12V Input
18	STARTER (Switch Side)
19	STARTER (Starter Side)
20	IMMOB (Common)
21	IMMOB (N/Open)
22	IMMOB (N/Closed)

primary harness wiring guide

This guide describes in detail the connection of each wire. Also included are possible applications of each wire. This system was designed with the ultimate in flexibility and security in mind. Many of the wires have more than one possible function. Please read the instructions carefully to ensure a thorough understanding of this unit and how it operates.

h1 black and h2 black—ground

Connect the BLACK wires H1 and H2 to separate ground locations on the motorcycle frame using a factory bolt that does NOT have any vehicle component grounds attached to it. If drilling a hole for a ground, a screw should be used in conjunction with a two-sided lock washer. It is also acceptable to splice into a factory ground wire(s).

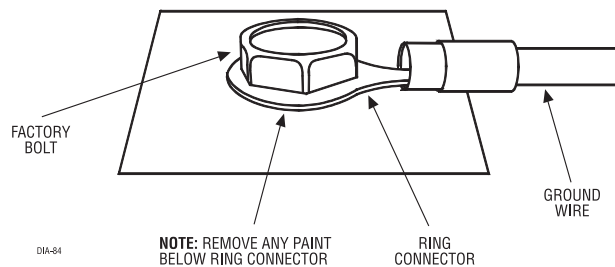

NOTE: Do Not connect to the negative side of the motorcycle battery.

h3 red/white auxiliary channel output

This wire produces a 200mA output when activated by the remote control and can be used to operate a variety of accessories. This output can be programmed to different types of output. Please see *System Features Programming* instructions

IMPORTANT! Never use this wire to drive anything but a relay or a low-current input! The transistorized output can only supply 200 mA of current. Connecting directly to a solenoid, motor, or other high-current device will cause it to fail.

h4 orange ground when armed

This wire provides a (-) ground output as long as the system is armed and will turn off when the system is disarmed. This output can be used to control additional accessories such as voice modules or pagers.

h5 yellow/white auxiliary horn output

This wire is a low current output (200mA) for an optional connection to the horn relay to sound when the system has been triggered. It can be programmed to either pulse or latch on when the alarm is triggered.

h6 black antenna

This wire is the antenna for the control module to receive commands from the transmitter. Do **NOT** cut this wire.

NOTE: The antenna wire should not be bundled with the other harness wires as this will reduce the effective range of the transmitter. Keep the antenna wire as straight and horizontal as possible. Also, keep the antenna wire as far away as possible from metal.

h7 blue LED (-) output

This wire connects to the LED through the BLACK mini-connector, pin 2.

h8 black low current ground for Valet switch

This wire connects to the Valet switch through the BLACK mini-connector.

h8 black low current ground—MUX

This wire connects to optional sensor connections.

h9 grey Valet input

This wire connects to the Valet switch through the BLACK mini-connector.

h10 red low current 12V—LED

This wire connects to the LED through the BLACK mini-connector, pin 1.

h10 red low current 12V—MUX

This wire connects to optional sensor connections.

h11 blue MUX 1 data

This wire connects to optional sensory data input (optional sensor 1). It will report on zone 2.

h12 green MUX 2 data

This wire connects to optional sensory data input (optional sensor 2). It will report on zone 3.

h13 black (+)12V input

Use the supplied fuse holder and a 5 amp fuse, and connect this wire to a permanent power supply. The fuse should be accessible to the vehicle user.

NOTE: Do not connect this wire to the positive battery terminal.

h14 white indicator output left

Connect this wire to the left indicator light.

h15 white/red indicator input

Use the supplied fuse holder and 15 amp fuse, and connect this wire to 12 volt (+) for positively switched indicators or ground for negatively switched indicators.

NOTE: A diode may need to be inserted in the motorcycle indicator relay supply if the indicator circuit can feed back to the ignition on the bike. To test if a diode is required, activate one of the direction indicators, turn ignition off and then arm the alarm. If the alarm triggers the indicators are supplying 12 volts to the alarm ignition wire.

h16 white indicator output right

Connect this wire to the right indicator light.

NOTE: Current handling capacity for H14 and H16 Indicator circuits is 10 amps continuous each.

h17 yellow ignition input (+)12 V

Connect this wire to any ignition wire on the motorcycle that remains positive while the starter button is pressed. It will report on zone 6 if triggered when armed.

h18 black starter (switch side)

Connect this wire to the starter input side from the starter switch.

h19 black starter (starter side)

Connect this wire to the starter side.

h20 black immob (common)

h21 black immob (N/open)

h22 black immob (N/closed)

The engine immobilizer wires can be installed as a normally open or normally closed circuit. The most common normally open circuits that can be used for immobilization are fuel pump, side stand switch or kill switch, etc. Locate the wire you are going to use, then cut it and make connections as described in the following diagram. Connect H20 to the end of the wire that is still connected to the switch; connect H21 to the end of the wire that is still connected to the load side of the circuit.

NOTE: H22 is only used for AC ignition circuits where the feed from the magneto to the coil pack is grounded to prevent the engine from running.

NOTE: The current handling of the immobilization circuits is 20 amps continuous.

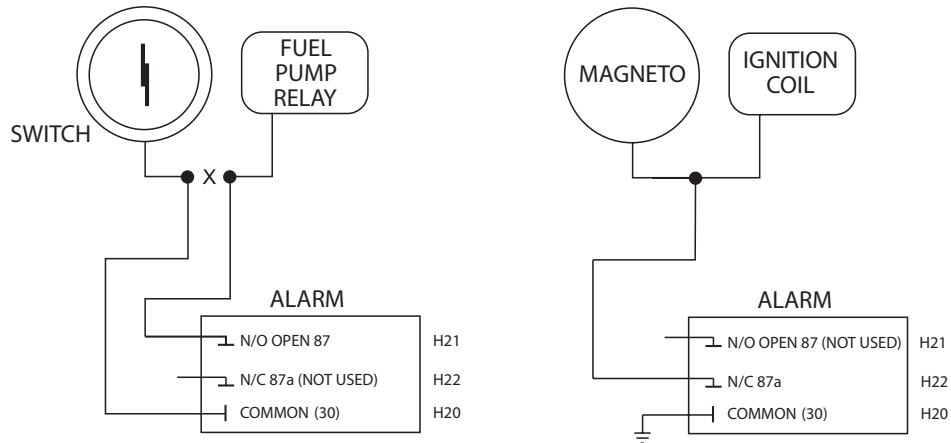

h23 blue programmable (-) input

This input will respond to a negative input with an instant trigger. It is programmable for normally open (ground to trigger) or normally closed (open circuit from ground to trigger). Pannier switch, side stand switch, helmet hooks and accessories are some examples of optional connection. It will report on zone 5. This wire also serves as a

remote start shunt input when ground is applied during remote start and aux output is programmed to remote start.

h1 and h24 grey twin bonded harness

Connect to the blue and black wires of the long lever protection switch. It will report on zone 4.

optional sensor harness, MUX wires

red and black wires

These wires supply constant 12 volts and ground to the sensor.

blue and green wires, zone 2 zone 3

These wires are multiplex inputs. If a (-) input of less than 0.8 seconds is supplied to either wire, the Warn Away® response will occur. This is indicated by 5 rapid chirps from the siren. A (-) input of longer than 0.8 seconds to either wire will initiate the triggered sequence and report Zone 2 or Zone 3.

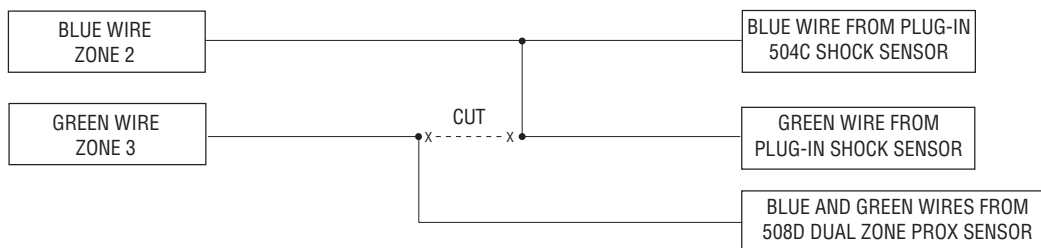

in-key 2-button transmitter—key blade installation

The exploded view below shows the assembly of the in-key 2-button transmitter. The owner must provide a spare ignition key to be used. Use the following procedure:

1. Measure the length of the key blade from the end of the key to the original plastic key housing. Add $9/32$ -inches to this measurement. That is how long the key blade needs to be when cut as $9/32$ -inches of the blade will be inside the In-key transmitter when the modification is completed. Make sure the cut is straight and free from burrs. Use a grinder or file if required.

NOTE: Do not cut the key where the end of the blade meets the plastic or the key may not be long enough to operate the ignition switch after modification.

2. For the key blade to fit properly it will need to be approximately 9/32-inches wide for the plastic insert to fit. Drill a 1/8-inch hole through the center of the key blade approximately 1/8-inch from the end.
3. Secure the key blade to the bottom housing using the Phillips screw provided. Fit the plastic insert shim over the top of the key blade and screw.
4. Assemble the unit as shown below using the two hex-head screws.

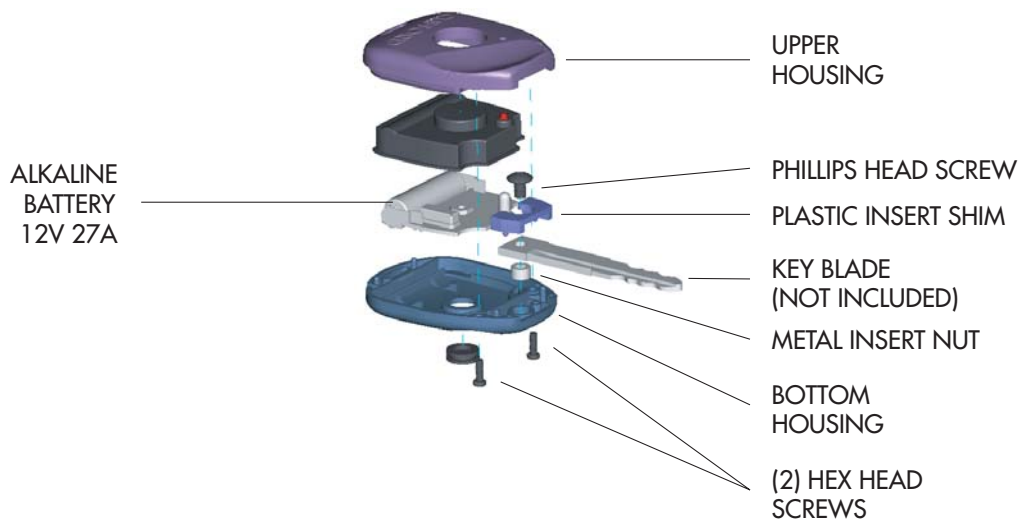

tilt sensor

The tilt sensor (integral to the control module) detects when the motorcycle is being moved in an attempt to steal it. It is capable of independently learning the bike's initial angles of vertical and horizontal inclination each time it is parked, ensuring the most accurate tilt sensing possible.

The control module can be mounted in any orientation. i.e. horizontally or vertically.

arming/disarming diagnostics

The systems microprocessor monitors and reports all active and violated zones when arming and disarming the system.

arming

Zones that are active at the time the system is armed are reported by a single status chirp called Malfunction AutoBypass. The specific zone bypassed is then reported by the LED. For more zone information, refer to *Table of Zones* section of this guide.

You are able to see exactly which zone is causing the bypass notification by disarming the system and turning the ignition on. The zone will be reported by flashing the active zone 5 times.

disarming

If a zone has been triggered, four disarm chirps will sound. The specific zone that was triggered is then reported by the LED when the ignition is turned on. For more zone information, refer to the *Table of Zones* section of this guide.

system status chirps

Action	No. of Chirps	Description
Arm	1	System armed
Arm	1 (3-second pause) 1	System armed with zone active and bypassed
Disarm	2	System disarmed
Disarm	4	System disarmed with tamper alert
High Security Disarm (siren On)	1	System silenced, but still armed, and all zone inputs are inactive and monitored.
High Security Disarm (siren On)	3	System silenced, but still armed, and a zone is still active and bypassed.
Disarm	5	System disarmed with a transmitter with zone in NPC.

high security disarm

While the siren is sounding, press the arm/disarm button once to silence the siren but leave the system in the armed state. To disarm the system, press the arm/disarm button a second time.

long term event history

This will report the last eight system triggers in reverse chronological order.



1. Press and hold  of the Valet switch.
2. While still holding , arm and disarm the system, then release the button.
3. The LED will start to flash to indicate the most recent trigger and proceed down to the eighth trigger. For more information, please refer to the Table of Zones section of this guide.

table of zones

When using the diagnostic functions, use the Table of Zones to see which input has triggered the system or was active during arming. It is also helpful in deciding which input to use when connecting optional sensors and switches. Zone reporting occurs when the system is disarmed and the ignition is turned on. The LED displays the last zone triggered 5 times.

NOTE: The Warning Zone response does not report on the LED.

LED Flashes	Trigger type	Input description
1	Tilt Sensor	Built-in Tilt Sensor
2	Mux 1	Mux 1 sensor input (BLUE wire)
3	Mux 2	Mux 2 sensor input (GREEN wire)
4	Instant	Normally Closed input (from protective switch)
5	Instant	Normally Open/Closed programmable input
6	Instant	Ignition Input
7	None	12 V Power interruptions

valet mode









Prevents the security system from automatically arming. In Valet Mode, the security system will not arm, even with the remote, but any accessory functions will continue to work normally.

to enter Valet mode

1. Turn the ignition On.
2. Enter PIN code as described below .

Retrieve the customer's preset PIN code as noted on the back of the owner's guide.

FOR EXAMPLE: To enter a PIN code of 4301—

Press  four times,
then  one time. This enters the digit 4.
then  three times,
then  one time. This enters the digit 3
and then  once. This enters a 0 as there was not
a previous digit entered with  .
then  one time,
and then  once. This enters the final digit 1.

3. When you enter the last digit continue to hold the  button for at least three seconds then release. The LED status indicator will light up and remain on if Valet Mode has been entered.

The LED status indicator will light steadily if you are entering Valet Mode and will turn off if you are exiting Valet Mode.

NOTE: The LED will turn off when the ignition is ON.

to exit Valet mode

When in Valet mode follow same steps outlined above. After Step 3, the LED will turn off indicating exiting of Valet mode.

system features programming





This system has many features that can be programmed to accommodate the user's personal preferences and make system installation easier. They are listed in two programming grids on the following pages. Many features have default settings that have been programmed at the factory and are indicated in bold type.

The User Selectable Features grid allows the user and installer to change operational features through the Valet switch. The Installer Selectable Features grid allows the installer to change input/output functions of the system to integrate with the motorcycle's specific characteristics.

programming instructions

It is a good idea to document changes by taking notes of all feature changes made in programming mode.



To enter the User Selectable Features programming:

1. Ignition on - Turn the ignition to the run position or start the engine.
2. Enter PIN - Refer to the previous discussion in the *Valet Mode* section.
3. Hold/Chirp/Release (User Selectable Features) - After entering the PIN code, press and hold  until a chirp is heard and the LED turns on, then release the button. You have now entered the feature selection position of the User Selectable Features grid.
4. Continue Hold (Installer Selectable Features) - Continue to hold the  button after the first chirp is heard for another 10-seconds, until the unit chirps 3-times. Release the button.
5. Column select - Press  the same number of times as the desired column. After a pause the siren will chirp the same number of times as the selected column for confirmation (e.g. 3-chirps means column 3 of the features is selected).
6. Feature select - Press  the same number of times as the desired feature. The siren will chirp with each press. The feature can now be changed using the remote control.
7. Feature change - Press the  button on the transmitter. If the system chirps once, the feature has just turned off or switched to the first setting in the grid slot for this feature.; if the system chirps twice, the feature has just turned on or switched to the second setting in the grid slot.

If the feature has more than two settings, continue pressing the arm/disarm button on the transmitter to toggle through the settings (e.g. if the feature has 1 through 5 settings, the system will chirp 1 through 5 times for each setting selected). If you continue to press and release the transmitter the feature setting will wrap back around to the first setting again. (e.g. if the feature has 3 settings you will hear, 1 chirp, 2, chirps, 3 chirps, 1 chirp, 2 chirps, etc).









To advance to another feature in the same column, press  the same number of times as the desired feature within 60 seconds; to change a feature in a different column begin at step 5 by entering the column number first and then the feature select in step 6.

NOTE: Refer to the Feature Descriptions sections of this guide for important notes and descriptions of the system features and programming.

8. Grid Jump - To change a feature in a *different* feature grid - Press and hold the  button for 10 seconds and you will jump from one grid to another. (e.g. You are in the user programming grid and would like to jump to the installer grid. Press and hold  for 10 seconds, you will hear 3 chirps indicating installer grid entry. Now program the features by entering the columns and rows as described previously.) 3 chirps are always heard when entering installer programming grid and 1 chirp when entering user programming grid.
9. Exit programming - To exit programming mode turn the ignition off or wait 60 seconds without pressing the Valet switch. The siren will chirp three times to indicate programming mode has been exited.

NOTE: After you change a feature setting, the feature counter is reset to zero. Hence, to change another feature in the same column you must press the  button the same number of times as indicated in the chart below.

user selectable features

Then Press \ First Press	1 x 	2 x 	3 x 
1 x 	Add new remote (autolearn)	Set PIN code	New remote learn arm/disarm only
2 x 	Passive arm on/off	Select siren sounds	New remote learn accessory output
3 x 	Chirps off/loud/ quiet	NPC on/off	New remote learn silent mode
4 x 	Panic on/off	Remote valet on/off	New remote learn remote valet
5 x 	Siren Duration 30/60/90 seconds	Reset to default (except transmitter and PIN code)	New remote learn sensor disable
6 x 	Not used	Not used	Clear all remotes from memory

user selectable features descriptions - column one

add new remote (for 3-button or 2-button in-key remotes only)

- Auto-learn new remote controls to the system (one at a time) in the standard button configuration. For more information, see programming note #1 at the end of feature descriptions section.

passive arm - on/**off**

- On: When the system sees the ignition turn off, it will begin a 30-second count-down before arming itself. The countdown is indicated by the system LED rapid flashing. After the first five seconds, you will hear one chirp and the indicators will flash. The system will arm 25 seconds later.
- Off: The transmitter must be used to arm the system.

chirps - off/loud/**quiet**

- Off: Chirps will not sound when arming/disarming the system (with the exception of arm/disarm diagnostic chirps and programming chirps).
- Loud: Chirps will sound when arming/disarming the system at full volume.
- Quiet: Chirps will sound when arming/disarming the system but at a lower volume than normal.

panic - **on**/off

Allows the remote to activate Panic Mode. The siren will sound for 30 seconds.

- On: The system will enter Panic Mode if the arm/disarm button is pressed for more than 2 seconds.
- Off: Panic Mode is disabled.

siren duration - 30/60/90

- The system will sound the alarm for the programmed duration (30/60/90 seconds) during an alarm trigger or when the system is put into panic mode.



user selectable features descriptions - column two



change valet/pin code

- This feature allows you to change the user's personal PIN code. For more information, see programming note #3.

select siren sounds

This feature allows you to select which siren sounds will be played back when the alarm is triggered. Use the following procedure to set this feature:

1. Enter the feature.
2. Press the  button of the remote to begin the playing of siren sounds.
3. Siren will generate each sound for 5-seconds.
4. To add the sound press the  button on the Valet switch while that sound is playing.
5. To delete the sound press the  button on the Valet switch while that sound is playing.

NOTE: After selecting or deleting a sound the siren will immediately play the next sound. If no sounds are selected by pressing the  or  button the system will remain in its previous setting.

npc **on/off**

Nuisance Prevention® Circuitry (NPC®) stops repeated triggering of the same zone. If one zone is triggered three times in one hour, that zone is bypassed for one hour, starting from the time of the third trigger. During that hour, if the system detects a trigger on that zone again, the system resets the one hour timer. If one hour passes and the zone has not triggered again, the zone is activated and can trigger the system again. NPC® monitors sensor inputs and the door trigger, but does not bypass the ignition trigger at any time. If NPC® is turned off, the system will respond to repeated triggers on the sensor inputs and will do so indefinitely. Some states have laws regulating how many times a security system can trigger before it is considered a nuisance and the vehicle is towed away.

remote valet - **on/off**

- On: The alarm can be put into Valet mode with the remote control.
- Off: The alarm cannot be put into Valet mode with the remote control.

reset all features to factory settings

- All system settings (except PIN and remote programming) in the User Programming grid will be reset to their default factory setting as indicated in bold lettering. No installer programmable features will be changed. The Multiple Event Total recall memory is also cleared.
- Press the arm/disarm button of the TX; the siren will chirp twice as confirmation.

user selectable features descriptions - column three

The features in this column pertain to programming individual transmitter channels in custom configurations. Following is an explanation of the features. Program the individual transmitter channels, referring to note #2 in the *Programming Notes* section.

arm/disarm only

- The remote control channel programmed into this feature will arm/disarm the system only.

NOTE: When programming a new remote control to custom configuration a channel must first be programmed to this feature before programming the remaining channels.

accessory (-) output

- The transmitter channel programmed into this feature will activate the accessory output.

silent mode

- The transmitter channel programmed into this feature will arm/disarm the system, but the siren will not chirp.

remote valet

- The transmitter channel programmed into this feature will make the system enter/exit Valet mode.

sensor disable

- The transmitter channel programmed for this feature will make the system bypass the sensors for one arming cycle only. On the next arming cycle, zones 1, 2, and 3 will be active.







clear all remotes

- This feature will erase all remote codes from the system memory. This feature is convenient for erasing any transmitters that have been lost, stolen, or incorrectly programmed into the system.
- After entering this feature press the  button on a transmitter that is programmed to the system; the siren will chirp twice to indicate that all transmitters have been erased from memory.

installer selectable features

To enter the Installer Selectable Features grid follow the instructions for the User Selectable Features with the exception of step 3. Perform step 3 as described below to enter the Installer Selectable Features grid.

Hold/Chirp/Release - After entering the PIN code, press and hold  until the siren chirps once. Continue holding for approximately 10 seconds until the siren chirps three times, then release the button. You have now entered the feature selection position of the Installer Selectable Features grid.

Then Press \ First Press	1 x 	2 x 	3 x 
1 x 	Acc. output auto-activate off/arm/disarm/both	One-time Valet On/Off	Normally Closed/ Normally Open trigger input H1/11
2 x 	Acc. output P1/P2 /timed/latch/ latch reset w/ignition/RS)	Accessory output timer duration 10-seconds	Horn output pulsed/latched
3 x 	Tilt Adjustment 1 degree /3 degrees	NOT USED	Automobilization On/Off

installer selectable features descriptions - column one

accessory output auto activation - **off/arm/disarm/both**

NOTE: The accessory output will not auto-activate if programmed to latched setting. Refer to program Note #4.

- **Off:** The accessory output will not automatically activate when the alarm is either armed or disarmed. It will only activate by pressing the  button on the remote control.
- **Arm:** The accessory output will auto-activate when the system is armed.
- **Disarm:** The accessory output will auto-activate when the system is disarmed.
- **Both:** The accessory output will auto-activate when the system is armed and disarmed.

accessory output programming - P1/P2/**timed**/latched/latched (ignition reset)/Remote Start

The auxiliary accessory output wire (H3 RED/WHITE) can be programmed for several different types of outputs.

- **P1 0.8 seconds:** The pulsed output is disabled with the ignition on or the alarm armed, but will remain on for as long as the button is pressed.
- **P2 0.8 seconds:** The pulsed output will operate any time and remain on for as long as the button is pressed.
- **Timed:** The output duration is 10 seconds as default but can be programmed for up to 255 seconds.
- **Latched:** The output is controlled by pressing the button(s) controlling the accessory. It will remain on until you press the button again.

- Latched (ignition reset): The output is controlled by pressing the button(s) controlling the accessory. It will remain on until you press the button again or if you turn on the ignition.
- Remote Start: The channel is specifically programmed to be connected to the 561T Valet remote Starter.

NOTE: Setting for trigger input H11 must be programmed to normally open for proper operation.

tilt adjustment - **1 degree**/3 degrees



This sets the sensitivity of the tilt sensor to either high or low levels of tilt change before activation.

installer selectable features descriptions - column two

one-time valet - on/**off**

- On - turns one-time Valet mode feature on.
- Off - turns one-time Valet mode feature off.

accessory output timer duration - **10-seconds** (1-255 seconds)

- Start Timer: Press the  button; the siren will chirp to signal the start of the timer duration setting.
- Stop Timer: Press the  button; the siren will chirp to signal the end of the timer duration setting, or for maximum time, do not press the  button.

NOTE: The timer max setting is 255 seconds.

installer selectable features descriptions - column three

trigger input h11 - normally closed/**normally open**

- Normally Closed: The alarm will trigger if H23 (BLUE wire) is disconnected from ground when the system is armed.
- Normally Open: The alarm will trigger if H23 (BLUE wire) is connected to ground when the system is armed.

horn honk - **pulsed**/latched

- Pulsed: H5 YELLOW/WHITE wire will generate a pulsing (-) output when the alarm is sounding. When arming and disarming the output does not operate.
- Latched: H5 YELLOW/WHITE wire will generate a constant (-) output when the alarm is sounding. When arming and disarming the output will pulse as per the standard chirp pulses.

automatic engine disable - **on**/off

When turned On the immobilization circuit automatically activates 30-seconds after , the ignition is turned off, exiting Valet mode, or exiting programming mode. The H4 ORANGE ground-when-armed output will not activate during Automatic Engine disable.

programming notes

NOTE: When programming a new transmitter to custom configuration, an arm/disarm channel must first be programmed before programming the remaining channels.

Note #1: Adding a new transmitter in auto-learn configuration

- Press the  button of the remote control. The siren will chirp once to confirm the new transmitter has been programmed.

Note #2: Adding a new transmitter in custom-configuration

- For the Arm/Disarm channel press the  button of the new transmitter. The siren will chirp once to confirm the new transmitter has been programmed.
- For the rest of the channels press the desired button on the transmitter to learn, and the siren will chirp once to confirm that the channel has been learned.

Note #3: PIN Programming

A PIN code can have one to four digits; each digit can be from 0-9.

NOTE: A PIN code cannot begin with a zero.

- Programming Procedure
 1. Enter the feature location (column 2, row 1) in the user-selectable programming grid.
 2. Immediately press and release of the Valet switch.
 3. Select each digit by pressing 1-9 times, and then press to enter the number into the system. To enter a zero, press only.

- To program a PIN code of 1032:
 1. Press and release once and once. You will hear one chirp.
 2. Press and release once. You will not hear a chirp after programming a zero.
 3. Press and release three times, and then press once. You will hear three chirps.
 4. Press and release two times, and then press once. You will hear two chirps.
 5. Wait for two siren chirps after a five second pause or five seconds after the last digit has been entered if using less than four digit code number.
 6. Turn off the ignition; the siren will chirp three times.
 7. The programming mode is now exited.

- PIN Code Confirmation Procedure

Begin this procedure within 15 seconds of finishing the programming sequence or the new code will not be set and the system will revert to the previous code.

 1. Turn on the ignition.
 2. Enter the new PIN code.
 3. Press and hold for three seconds.
 - LED turns on: New PIN code is learned and programming is complete.
 - LED stays off: New PIN code is not learned and the system reverts to the old PIN code. Repeat the programming sequence.



Note #4: Accessory Channel

- The accessory channel can be programmed to different types of outputs including a pulsed output that does not function when ignition is on or the system is armed, a pulsed output regardless of the ignition/armed state, a timed output, a latched output, a latched output that resets with ignition on and a Remote start output for connection with a 561T remote starter.
- The accessory channel can be programmed to auto-activate with the arm command of the transmitter, the disarm command of the transmitter, or both. Auto-activate can also be turned off (factory default).

rapid resume logic

The Rapid Resume Logic feature ensures that when the security system is powered back up after being disconnected, the system will resume the same state it was in before power was lost. For example, if power is disconnected during a full trigger sequence, the system will still be in the full trigger sequence when power is reconnected to the unit. If power is disconnected while the unit is disarmed, it will still be disarmed when power is restored.

remote control sensor disable

1. Arm the system.
2. Use the transmitter to bypass the sensor by pressing the  and  buttons at the same time.
3. The lights will flash four times. All Warn Away® zones are now bypassed.
4. Transmit the sensor bypass channel again.
5. The lights will flash four times again. The sensor Warn Away® and full trigger zones are now bypassed. To bypass the tilt sensor press the sensor disable buttons twice.
6. The sensor zones will reset when disarmed.

NOTE: Sensor disable can be performed at any time after the alarm has been armed.

adjusting the tilt sensor

Select either a high sensitivity threshold for extreme sensitivity, or a low sensitivity threshold can be selected for normal sensitivity.

auto-immobilization feature

Immobilizer circuits automatically activate after 30-seconds.

NOTE: H4 orange ground when armed will not activate during Auto-Immobilization

auto-immobilization sequence

1. Turn ignition off or disarm alarm.
2. After 30-seconds the systems Immobilization circuits activate and engage the starter and engine interrupts.
3. LED flashes at ½ normal speed.



Disarm the system when immobilized

Use one of the following methods to turn off auto-immobilization

- Turn ignition on and press the  button of the transmitter.
- Arm the alarm and then disarm the alarm.
- Turn the ignition on and enter the system Valet/PIN code.

troubleshooting and system testing

Checking arm/disarm.

- Use the  button on both remote controls to arm and disarm the alarm.
- Use the  button on the 3-button remote to silently arm and disarm the alarm.
- Repeat both tests at required distance to test range.

Testing disarming without a remote

1. Turn the ignition On.
2. Enter the preset PIN code as described in the *Programming Instructions* section.
3. Then press the  button once to disarm without a remote.

Testing the tilt sensor.

- Arm the alarm with the motorcycle resting on its side stand. Wait at least 10 seconds.
- Tilt the motorcycle upwards as though you were going to push it away. The alarm should trigger.
- Adjust sensitivity as necessary.

Testing Ignition Trigger.

- Arm alarm
- Turn ignition on, alarm should trigger.
- Disarm alarm.

Testing the protection switch.

- Arm the alarm system.
- Attempt to remove the panel required to access the alarm control unit.
- The alarm should trigger. Adjust or reshape protection switch lever if required.

Testing the N/O–N/C programmable input.

- Arm the alarm.

- Open or close the switch or circuit connected to the normally open/normally closed programmable input.
- The alarm should trigger.

Testing the battery back up siren

- Arm alarm.
- Pull system 5 amp fuse. The alarm should sound. It should not sound for longer than 5 minutes in total.
- Reconnect fuse. Test system again to verify correct functions.

The system will not arm or disarm.

- Make sure the ignition is not turned on or that the yellow ignition wire does not have 12volts.
- Make sure the systems 5 amp main fuse has been installed or is not blown.

The engine immobilization circuit works the wrong way round. i.e.. the circuit works when the alarm is armed but doesn't when the alarm is disarmed.

- Check the correct normally open or normally closed wires have been used for the bikes ignition circuit.
- Check that the common wire has been used with either the normally open or normally closed wire.
- If normally open and normally closed wire is used the circuit will not work.

The Valet switch does not work.

- Make sure that it is plugged in. (See the Plug-In Harness section of this guide.)
- Check the System Features Learn Routine for the default PIN code.
- Has the PIN code been changed?

The status LED does not work.

- Make sure that it is plugged in and the red and blue wires are oriented properly in the plug. (See the *Plug-In Harnesses* section of this guide.)

wiring quick reference guide

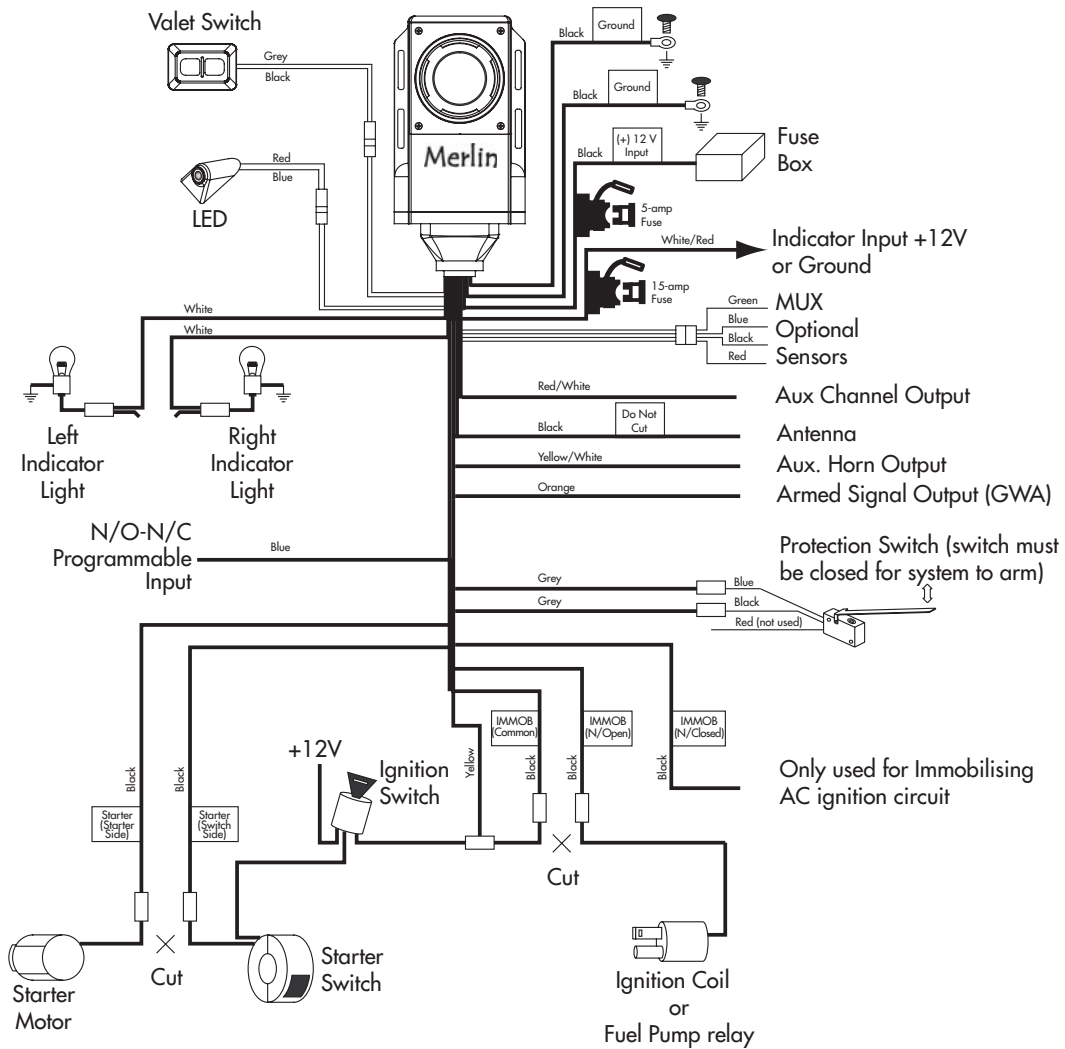

NOTE: The power supply range is 9 to 16 volts.

