

# ***AM1 Security System*** installation guide



© 2005 Directed Electronics, Inc. Vista, CA N427A 01-05

*NOTE: This product is intended for installation by a professional installer only! Any attempt to install this product by any person other than a trained professional may result in severe damage to a vehicle's electrical system and components.*

## trademarks and copyrights

---

Bitwriter®, Clifford®, Code-Hopping®, Directed®, Doubleguard®, ESP®, FailSafe®, Ghost Switch®, Learn Routine™, Nite-Lite®, Nuisance Prevention®, NPC®, Revenger®, Silent Mode™, Soft Chirp®, Stealth Coding™, Stinger®, Valet®, Vehicle Recovery System™, VRS™, and Warn Away® are all Trademarks or Registered Trademarks of Directed Electronics, Inc.

# contents

what is included . . . . .	3	four-pin optional sensor harness .21	
control module . . . . .	3	RED wire . . . . .	21
installation points to remember . . .3		BLACK wire . . . . .	21
before beginning the installation: 4		BLUE, GREEN wires . . . . .	21
after the install: . . . . .	4	dealer master control loop . . . . .	21
tools required . . . . .	4	door lock learn routine . . . . .	21
deciding on component location . . .5		to learn lock: . . . . .	22
control module . . . . .	5	to learn unlock: . . . . .	22
integrated LED/Valet® switch . . . .6		to exit the learn routine: . . . . .	23
starter kill relay . . . . .	6	on-board dual stage shock sensor 23	
connecting your wires . . . . .	6	internal programming jumper . . .24	
obtaining constant 12V . . . . .	6	zones . . . . .	24
finding the 12V switched . . . . .		long term event history . . . . .	25
ignition wire . . . . .	7	rapid resume logic . . . . .	25
finding the door pin switch circuit 9		feature programming . . . . .	26
main harness wire . . . . .		to enter feature programming . . . .	
connection guide . . . . .	10	routine . . . . .	26
main harness wiring diagram . . .10		once a feature is programmed . . .27	
main harness wiring guide . . . . .	10	accessing another feature . . . . .	27
auxiliary harness wire . . . . .		accessing another menu . . . . .	27
connection guide . . . . .	15	exiting feature programming . . .27	
auxiliary harness wiring diagram 15		Bitwriter® ONLY features . . . . .	28
auxiliary harness wiring guide . . .15		features #1 menu . . . . .	29
keyless entry systems . . . . .		features #2 menu . . . . .	30
—three types . . . . .	17	master dealer remotes . . . . .	31
door lock harness wire . . . . .		master dealer remote learn . . . . .	
connection guide . . . . .	20	routine . . . . .	31
plug-in harnesses . . . . .	20	troubleshooting . . . . .	33
integrated LED/Valet® switch . . .20		wiring quick reference guide . . . .37	
data port—Bitwriter® . . . . .	20		



## what is included

- Control module
- 12-pin main harness
- 7-pin door monitor/Aux harness
- 4-pin sensor harness
- Integrated LED/Valet switch
- 3-pin door lock harness

## control module

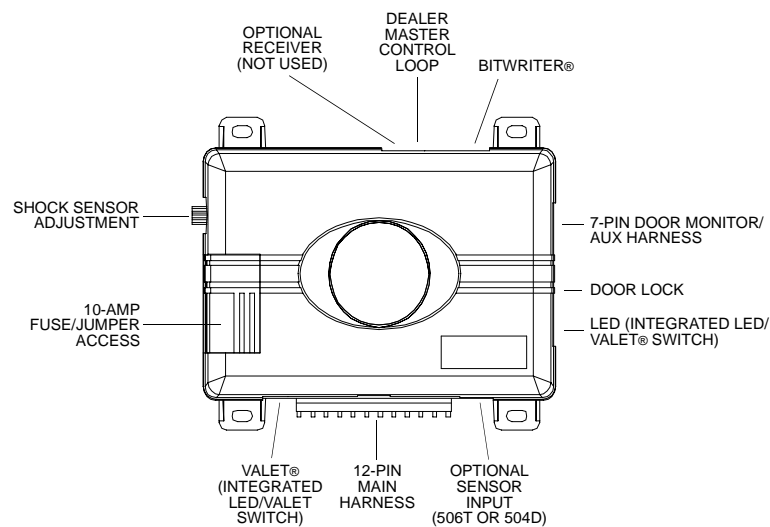

## installation points to remember

This product represents many years of research and development. It is very sophisticated and should be installed by experienced security installers only. Please do not attempt installation of this product without reading this guide. The system has been designed to provide the ultimate in security, coupled with limitless convenience and expansion options.

This product is not intended for consumer installation and will have **NO WARRANTY** unless it is installed by an authorized dealer.

Do not disconnect the battery if the vehicle has an anti-theft coded radio. If equipped with an airbag, avoid disconnecting the battery if possible.

***IMPORTANT!** Please read this entire installation guide before beginning the installation. The installation of this security system requires interfacing with many of the vehicle's systems. Many new vehicles use low-voltage or multiplexed systems which can be damaged by low resistance testing devices, such as test lights or logic probes. Test all circuits with a high-quality digital multi-meter before making the connections.*

***IMPORTANT!** Many airbag systems will display a diagnostic code through their warning light after they lose power. Disconnecting the battery requires this code to be erased, a procedure that can require a trip to the dealer.*

### **before beginning the installation:**

- Check with the customer to determine the integrated LED/Valet switch location.
- Remove the domelight fuse. This prevents accidentally draining the battery.
- Roll down a window to avoid being locked out of the car.

### **after the install:**

- Test all functions. The "Using Your System" section of the Owner's Guide is very helpful when testing.
- When testing, don't forget that this system is equipped with Nuisance Prevention<sup>®</sup> Circuitry. NPC<sup>™</sup> can bypass both sensor zones, making them seem to stop working.
- Carefully reassemble the under-dash trim panels.
- Inspect the engine compartment for tools that may have been left behind.

## **tools required**

This is a general list of tools required to complete the installation of this security system in most vehicles. Some vehicles may require additional tools.

- Digital multi-meter
- Wire cutters/strippers
- Nutdriver and/or socket set
- Panel removal tool

- Solderless terminal crimpers
- Cordless power drill
- Torx driver set
- Drill bit set
- Phillips head screwdriver
- Work light

## deciding on component location

### control module

Never put the control module in the engine compartment!

The first step in hot-wiring a vehicle is removing the driver's side underdash panel to access the starter and ignition wires. If the control module is placed just behind the driver's side dash it can easily be disconnected.

When locating the control module, try to find a secure location that will not require you to extend the harnesses' wires (they are 1.5 meters long). Keep it away from the heater core (or any other heat sources) and any obvious leaks.

Some good control module locations: Above the glove box, inside the center console, above the underdash fuse box, above the radio, etc.

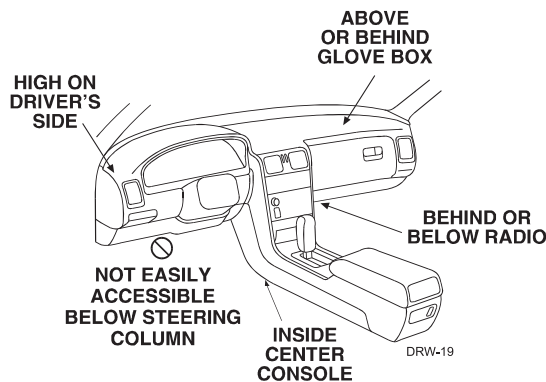

## integrated LED/Valet® switch

Things to remember when positioning the integrated LED/Valet® switch:

- It should be visible from both sides and the rear of the vehicle, if possible.
- It needs at least 1-1/2" clearance to the rear.
- It is easiest to use a small removable panel, such as a switch blank or a dash bezel. Remove it before drilling your 5/16" hole.

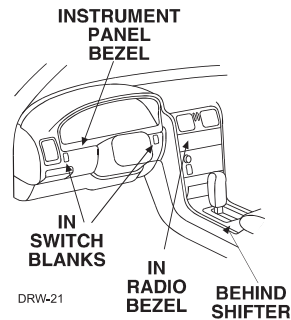

***IMPORTANT!** Do NOT use a step drill bit (unibit) for drilling the 5/16" hole. It is recommended to use a 5/16" drill bit. Use care to ensure the hole is drilled straight. Drilling at an angle can cause product malfunction.*

## starter kill relay

If the Starter Kill Relay or its connections are immediately visible upon removal of the underdash panel, they can easily be bypassed. Always make the relay and its connections difficult to discern from the factory wiring! Exposed yellow butt connectors do not look like factory parts, and will not fool anyone! For this reason, routing the starter kill wires away from the steering column is recommended.

## connecting your wires

Now that you have decided where each component will be located, you're going to find the wires in the car that the security system will be connected to.

***IMPORTANT!** Do not use a 12V test light to find these wires! All testing described in this manual is described using a digital multimeter.*

## obtaining constant 12V

We recommend two possible sources for 12V constant: The (+) terminal of the battery, or the constant supply to the ignition switch. **Always install a fuse within 12 inches of this connection.**



**IMPORTANT!** Do not remove the fuse holder on the red (H1/11) wire. It ensures that the control module has it's own fuse, of the proper value, regardless of how many accessories are added to the main power feed.

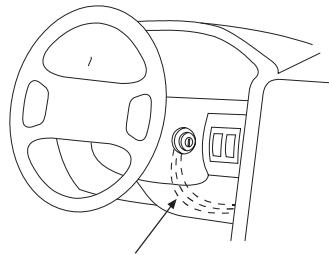

CONSTANT 12V DRW-23

## finding the 12V switched ignition wire

The ignition wire is powered when the key is in the run or start position. This is because the ignition wire powers the ignition system (spark plugs, coil) as well as the fuel delivery system (fuel pump, fuel injection computer). Accessory wires, on the other hand, lose power when the key is in the start position to make more current available to the starter motor. Use the following procedure to find (+)12V with your multimeter.

1. Set to DCV or DC voltage (12V or 20V is fine).
2. Attach the (-) probe of the meter to chassis ground.
3. Probe the wire you suspect of being the ignition wire. The steering column harness or ignition switch harness is an excellent place to find this wire.

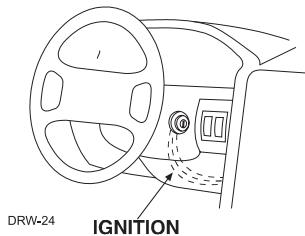

DRW-24

IGNITION

4. Turn the ignition key switch to the run position. If your meter reads (+)12V, go to the next step. If it doesn't, probe another wire.
5. Now turn the key to the start position. The meter display should stay steady, not dropping by more than a few tenths of a volt. If it drops close to or all the way to zero, go back to step 3. If it stays steady at (+)12V, you have found an ignition wire.

## finding a parking light wire

The parking light wire is often found near the switch. Many cars have the switch built into the turn signal lever, and in these cars the parking light wire can be found in the steering column. The same wire is often available in the kick panel or running board.

### (+) parking light wire

Use the following procedure to find (+) parking light wire with your multimeter.

1. Set to DCV or DC voltage (12V or 20V is fine).
2. Attach the (-) probe of the meter to chassis ground.
3. Probe the wire you suspect of being the parking light wire. Usually, the area near the headlight/parking light switch is an excellent area to start, as is the kick panel.
4. Turn on the parking lights. If your meter shows (+)12V, turn off the parking lights and make sure it goes back to zero.
5. If it does return to zero, turn the parking lights back on and, using the dash light dimmer control, turn the brightness of the dash lights up and down. If the meter changes more than a volt when using the dimmer, look for another wire. If it stays relatively close to (+)12V, you have found your parking light wire.

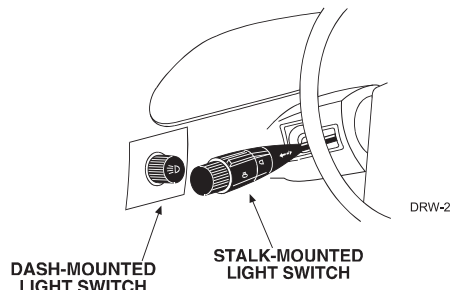

### (-) parking light wire

Use the following procedure to find (-) parking light wire with your multimeter.

1. Set to DCV or DC voltage (12V or 20V is fine).
2. Attach the (+) probe of the meter to +12V.
3. Probe the wire you suspect of being the parking light wire. Usually, the area near the headlight/parking light switch is an excellent area to start, as is the kick panel.

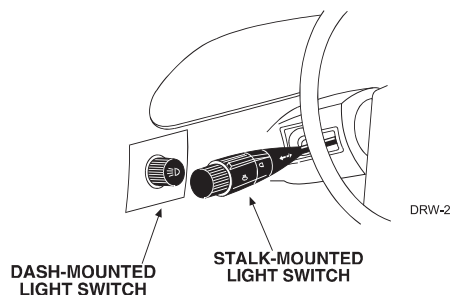

4. Turn on the parking lights. If your meter shows (+)12V, turn off the parking lights and make sure it goes back to zero.
5. If it does return to zero, turn the parking lights back on and, using the dash light dimmer control, turn the brightness of the dash lights up and down. If the meter changes more than a volt when using the dimmer, look for another wire. If it stays relatively close to (+)12V, you have found your parking light wire.

## finding the door pin switch circuit

The best places to find the door switch wire are:

At the pin switch: When testing at the pin switch, check the wire to ensure that it "sees" all the doors. Often, the passenger switch will cover all the doors even if the driver's switch will not.

At the dome light: This may not be your best choice if the vehicle has delayed domelight supervision, but it will work in vehicles with completely diode-isolated pin switches.

Often the door switch wires, described above, can also be found in the windshield pillars, running boards or kick plates.

Use the following procedure to find the door pin switch wire with your multimeter.

1. Set to DCV or DC voltage (12V or 20V is fine).
2. In most cars, fasten the (+) probe of your meter to (+)12V constant.
3. Probe the wire you suspect of being the door trigger wire. If the meter reads (+)12V when any door is opened and the meter goes to 0 with the door closed, you have found a trigger wire.

*NOTE: Make sure the wire you use "sees" all the doors! Some newer vehicles lack standard-type pinswitches. The dome light in these vehicles is turned on when the door handle is lifted. These usually have a wire coming out of the door into the kick panel which will provide a (-) trigger for all doors.*

# main harness wire connection guide

## main harness wiring diagram

H1/1	ORANGE	(-) 500mA Ground When Armed
H1/2	WHITE	(+)/(-) Light Flash Output
H1/3	WHITE/BLUE	No Function
H1/4	BLACK/WHITE	(-) 200mA Domelight Supervision Output
H1/5	GREEN	(-) Door Trigger Input
H1/6	BLUE	(-) Instant Trigger (Hood and Trunk Pin)
H1/7	VIOLET	(+) Door Trigger Input
H1/8	BLACK	(-) Chassis Ground Input
H1/9	YELLOW	(+) Ignition Input
H1/10	BROWN	(+) Siren Output
H1/11	RED	(+) 12V Constant Power Input
H1/12	RED/WHITE	(-) 200mA Auxiliary Channel/Delayed Accessory Output

## main harness wiring guide

**H1/1 ORANGE (-) 500 mA ground-when-armed output:** This wire supplies a (-) ground as long as the system is armed. This output ceases as soon as the system is disarmed. This wire controls operation of the pre-wired starter kill relay and can be used to control other optional accessories.

*NOTE: If connecting the orange wire to control another module, such as a 529T or 530T window controller, a 1 amp diode (type 1N4004) will be required. Insert the diode as shown below.*

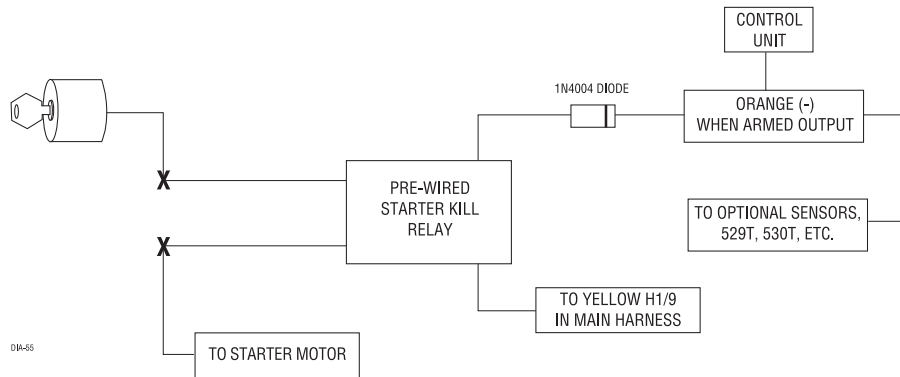

**IMPORTANT!** Never interrupt any wire other than the starter wire.

**H1/2 WHITE light flash output:** As shipped, this wire should be connected to the (+) parking light wire. It will supply a (+) 10A output. If the light flash polarity fuse jumper inside the unit is moved to the opposite position (see Internal Jumpers), this wire supplies a (-) 10A output. This is suitable for driving (-) parking light wires.

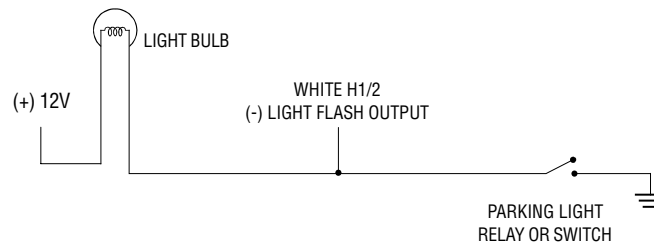
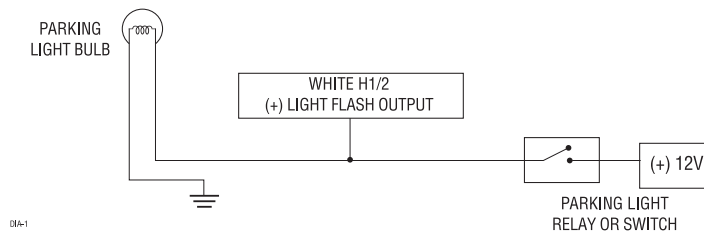

**H1/3 WHITE/BLUE no function.**

**H1/4 BLACK/WHITE (-) 200 mA domelight-supervision output:** Connect this wire to the optional domelight supervision relay.

***IMPORTANT!** This output is only intended to drive a relay. It cannot be connected directly to the domelight circuit, as the output cannot support the current draw of one or more bulbs.*

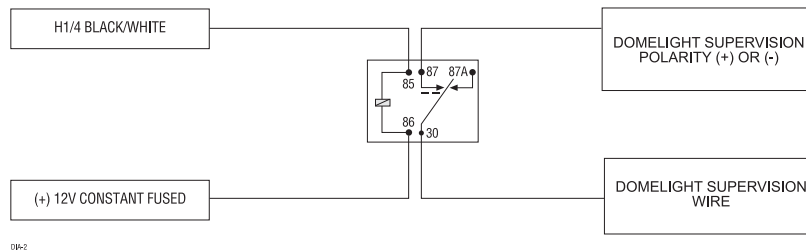

**H1/5 GREEN (-) door trigger input:** Most vehicles use negative door trigger circuits. Connect the green wire to a wire which shows ground when any door is opened. In vehicles with factory delays on the domelight circuit, there is usually a wire that is unaffected by the delay circuitry.

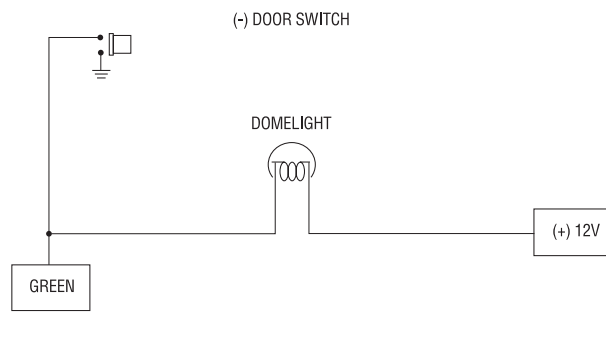

**H1/6 BLUE (-) instant trigger:** This input will respond to a negative input with an instant trigger. It is ideal for hood and trunk pins and will report on zone one.

**H1/7 VIOLET (+) door trigger input:** This wire is used in vehicles that have a positive (+) switched dome light circuit . Connect the violet wire to a wire that shows (+)12V when any door is opened, and ground when the door is closed.

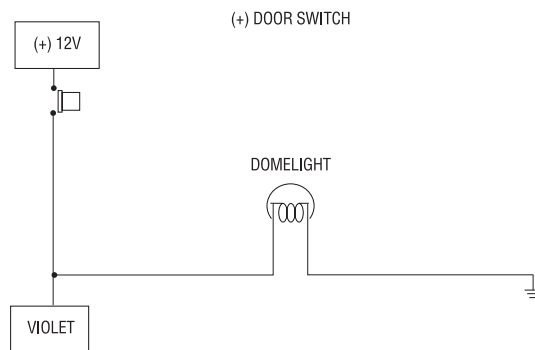

**H1/8 BLACK (-) chassis ground connection:** Connect this wire to bare metal, preferably with a factory bolt rather than your own screw. Screws tend to either strip or loosen with time. All components, should be grounded to the same point in the vehicle if possible.

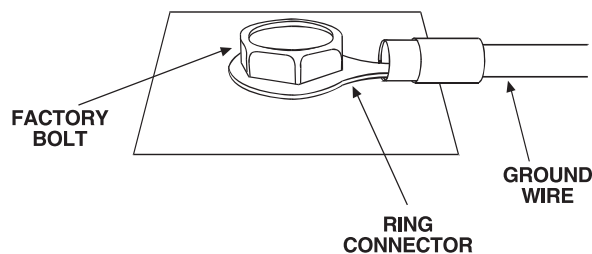

**H1/9 YELLOW (+) ignition input:** Connect this wire to the (+)12V ignition wire. This wire must show (+)12V with the key in Run position and during cranking. Take care to insure that this wire cannot be shorted to the vehicle chassis at any point.

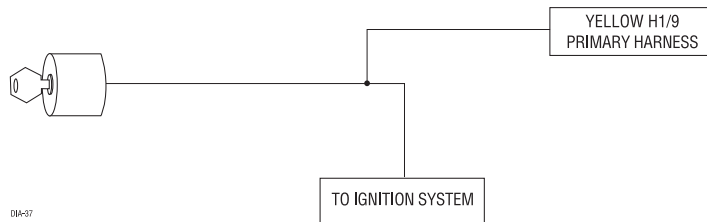

**H1/10 BROWN (+) siren output:** This output can be used if an optional siren is installed. Connect this to the RED wire of the siren. Connect the BLACK wire of the siren to (-) chassis ground, preferably at the same point as the control module's BLACK ground wire.

**H1/11 RED (+)12V constant power input:** Before connecting this wire, remove the supplied fuse. Connect to the battery positive terminal or the constant 12V supply to the ignition switch.

*NOTE: Always use a fuse within 12 inches of the point you obtain (+)12V. Do not use the 1.5A fuse in the harness for this purpose. This fuse protects the module itself.*

**H1/12 RED/WHITE (-) 200mA auxiliary channel/delayed accessory output:** If programmed for an auxiliary output, this wire will provide a (-) pulse when the lock button on the factory transmitter is pressed twice within three seconds. This output can be used to control optional accessories. If programmed for delayed accessory output, this wire will provide (-) ground when the ignition is turned off and will continue to output (-) ground until a door is opened then closed. This can be used to energize the accessory circuit in the vehicle to keep the radio and other accessories on after the ignition is turned off.

*IMPORTANT! Never use this wire to drive anything but a relay or a low-current input! This transistorized output can only supply (-) 200 mA, and connecting directly to a solenoid, motor, or other high-current device will cause the module to fail.*

*NOTE: Sensors and other triggers can be bypassed if this output is used to open the vehicle trunk while the alarm is armed. See H2/5 Gray zone shunting for programming and connection descriptions.*



# auxiliary harness wire connection guide

## auxiliary harness wiring diagram

H2/1	BROWN	(-) Horn Honk Output
H2/2	GREEN	Arm Input
H2/3	RED	Disarm Defeat Input
H2/4	BLUE	Disarm Input
H2/5	GRAY	(+) Trunk Release/Sensor Shunt Input
H2/6	VIOLET/BLACK	No Function
H2/7	YELLOW/BLACK	Light Flash Monitor Input

## auxiliary harness wiring guide

**H2/1 BROWN (-) horn honk output:** This wire supplies a 200 mA (-) output that can be used to honk the vehicle's horn. It provides a pulsed output when the security system is armed/disarmed and in the triggered sequence or in panic mode. In most vehicles with (-) horn circuits this wire can control the vehicle's horn without adding a relay. If the vehicle has a (+) horn circuit, an optional relay must be used to interface with the vehicle's horn circuit.

***IMPORTANT!** Never use this wire to drive anything but a relay or a low-current input! This transistorized output can only supply (-) 200 mA, and connecting directly to a solenoid, motor, or other high-current device will cause the module to fail.*

**H2/2 GREEN for arm input:** Connect this GREEN wire to a wire that changes state when the doors are locked using the factory keyless entry transmitter. This wire can accept a positive (+) or negative (-) input. The vehicle's power door lock motor wire is ideal.

**H2/3 RED disarm defeat input:** This wire is used to prevent the interior door lock switches from disarming the system. To determine the best location to interface this wire, first test the operation of the remote keyless entry system. When unlocking the doors with the factory remote transmitter, does the driver's door unlock first? Most

vehicles operate this way. If this is the case connect the RED wire to the passenger unlock motor wire. When testing this wire be sure that it shows 12V (+) ONLY when the unlock button on the factory transmitter is pressed the second time to unlock the passenger doors. If the factory keyless entry system unlocks all of the doors at the same time, it is recommended that the H2/7 YELLOW/BLACK wire be used for disarm defeat input.

*NOTE: The H2/3 wire connection is not required if using H2/7 YELLOW/BLACK as a disarm defeat wire.*

**H2/4 BLUE disarm input:** Connect the BLUE wire to a wire that changes state when the doors are unlocked using the factory keyless entry transmitter. If the factory transmitter unlocks the driver's door first, the BLUE wire must be connected to the wire that changes state when the driver's door is unlocked by itself. In this case, find the driver's door unlock motor wire. In most vehicle's this wire can be found in the driver's kick panel.

*NOTE: Some vehicles (some models of the Honda, GM and Ford) have long door lock pulses. These long pulses may interfere with the disarm function of this system when unlocking all doors using the factory OEM remote. Use the supplied door unlock pulse adapter for these vehicles. Refer to the diagram below.*

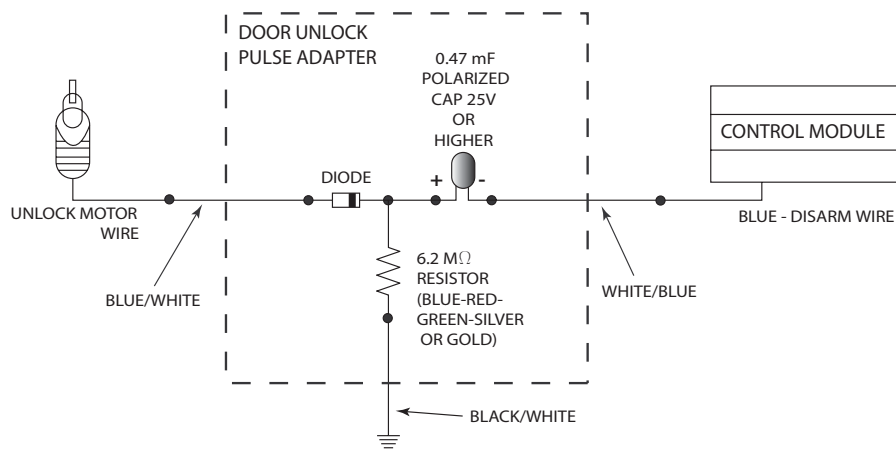

**H2/5 GRAY trunk release/sensor shunt input:** This input is used to bypass the sensor inputs when the trunk is opened using the factory keyless entry system or trunk release relay while armed. When the system receives a (+) input on this wire, zones 1, 2 and 4 are bypassed for 3-seconds. If during that 3-seconds, ground is applied to the H1/6

BLUE wire then the alarm zones are bypassed (See Feature menu 1/8) and will remain bypassed until the ground input is removed. This means that when the trunk is open with the factory transmitter the only triggers that remain active while the trunk is open are the doors and ignition. 3-seconds after the trunk is closed the bypassed zones again become active.

**H2/6 VIOLET/BLACK no function.**

**H2/7 YELLOW/BLACK light flash monitor input:** This input monitors the factory system light flash output and can be used as a disarm defeat wire. Connect this wire to the light flash wire that flashes when the factory transmitter is used. This may be a status LED, parking lights, reverse lights, etc., depending on the vehicle type and manufacturer. This wire can accept a (+) positive or (-) negative input.

### keyless entry systems—three types

There are three main types of keyless entry systems. Systems that unlock the driver's door first and have internal relays, systems that unlock the driver's door first but have external relays, and systems without driver's priority door unlock.

factory remote—driver's door unlock

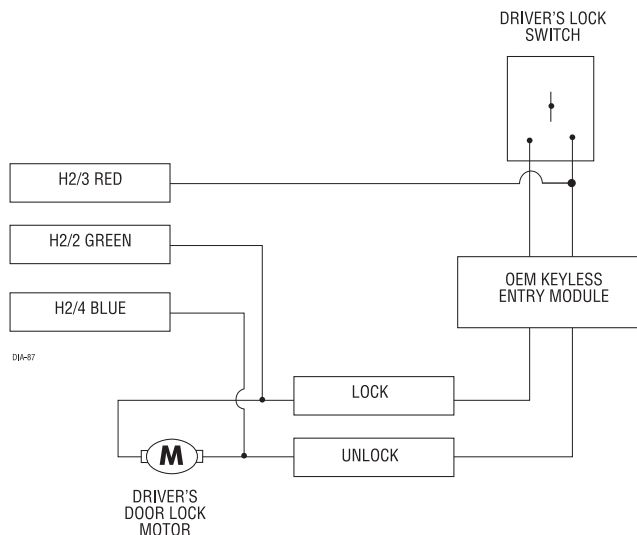



no priority—driver's door unlock

This type of keyless entry system is common in import vehicles as well as many Jeep vehicles. When unlocking the doors with the transmitter all doors unlock at the same time. It is recommended to use H2/7 YELLOW/BLACK wire for Disarm Defeat instead of the H2/3 RED wire. This input wire monitors the factory system light flash output. Connect this wire to the light flash wire that flashes when the factory transmitter is used. This may be a status LED, parking lights, reverse lights, etc., depending on the vehicle type and manufacturer. Do NOT connect this wire to the domelight. This wire can accept a (+) positive or (-) negative input.

For installation, please refer to the diagram below.

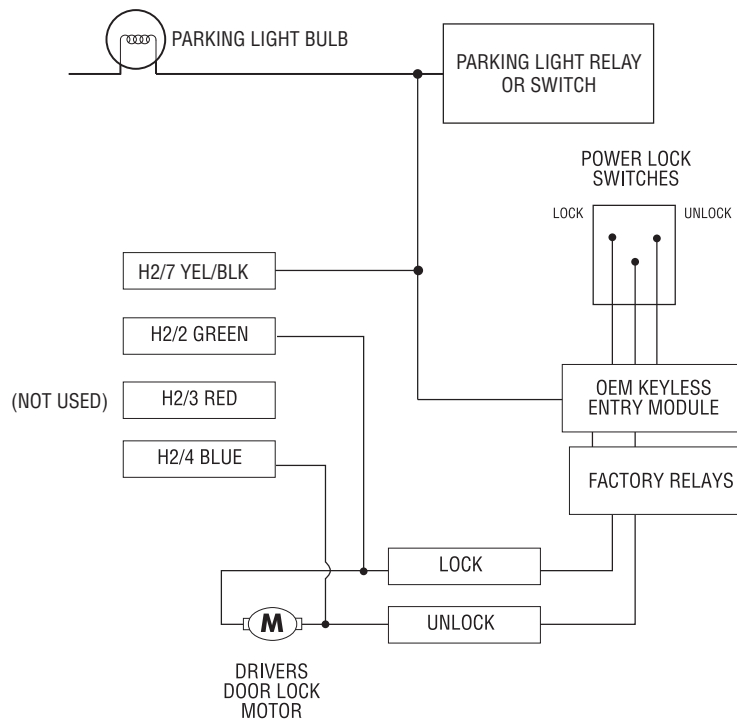

## door lock harness wire connection guide

These door lock outputs are for Passive arming control of the factory door locks. They can also be used to control the door locks with the ignition switch for vehicle that do not have this feature in the factory RKE system.

<b>H3/A</b>	GREEN	(-) Lock, (+) Unlock Output
<b>H3/B</b>		Not Used
<b>H3/C</b>	BLUE	(-) Unlock, (+) Lock Output

The control module can control 2 common power door lock types without any additional parts. With certain vehicles, or if an actuator is to be installed, either a 451M Door Lock Relay Satellite or two relays will be required. Refer to TechTips document 1041.

## plug-in harnesses

### integrated LED/Valet® switch

The integrated LED/Valet® switch should be accessible from the driver's seat. The Valet® part of the integrated LED/Valet® switch plugs into the blue port on the side of the unit. Check for rear clearance before drilling a 5/16-inch hole and mounting the switch. The LED part of the integrated LED/Valet® switch operates at 2V DC and plugs into the white port on the side of the unit. Make sure the LED wires are not shorted to ground as the LED will be damaged.

### data port—Bitwriter®

The black three-pin port can be used for programming the unit using the Directed Bitwriter, a hand held programming tool. The Bitwriter also allows programming of features that are not available in the feature menus.

## four-pin optional sensor harness

### RED wire

The red wire supplies constant power to the optional sensor.

### BLACK wire

The black wire supplies ground to the optional sensor.

### BLUE, GREEN wires

The blue and green wires are multiplex inputs. They are both tied to the same zone. If an input of less than 0.8 seconds is supplied to either wire the Warn-Away® response will occur. An input longer than 0.8 seconds to either wire will initiate the triggered sequence and report zone 4. This port can be used for optional sensors such as: the 506T—glass breakage sensor, or the 504D—field disturbance sensor.

## dealer master control loop

This 2-pin black connector when removed in disarmed state from the control module will reset the system back to allow the full set of customer settings and remove the dealer remote from memory.

*NOTE: For programming of dealer master remotes (Directed p/n 465D), the dealer master control loop **MUST** be plugged into the module.*

## door lock learn routine

Before the unit will respond to the factory remote keyless system, it must learn the polarity of the door lock wires. To learn the lock polarity:

*NOTE: It is important that all the INPUT signals to the control module are in the rest status state (no activity) before entering the learn routine.*

## to learn lock:

*NOTE: Make sure the doors, hood and trunk are closed so the factory RKE system operates as it would when the user is using it.*

1. **With all the doors, hood and trunk closed:** Press and HOLD the integrated LED/Valet® switch.
2. **Within 5-seconds:** Turn the ignition On and then Off (leave for less than 2-seconds in the on position).
3. **Within 5-seconds:** Release the integrated LED/Valet® switch.
4. **Within 5-seconds:** Press and release the integrated LED/Valet® switch once.
5. **Within 5-seconds:** Press and HOLD the integrated LED/Valet® switch. The LED will flash to indicate that the lock routine is ready to be learned.
6. **Press lock button:** Press the lock button on the factory transmitter. Wait for the LED to illuminate to indicate the the lock learn was successful. If the learn was unsuccessful the LED would continue to flash.
7. **Release the integrated LED/Valet® switch.** Now advance to the learn Unlock routine.

## to learn unlock:

1. **Within 5-seconds** of the learn lock routine (step 7), press and release the integrated LED/Valet® switch once.
2. **Within 5-seconds:** Press and HOLD the integrated LED/Valet® switch. The LED will flash in groups of two flashes to indicate that the unlock routine is ready to be learned.
3. **Press unlock button:** Press the unlock button on the factory transmitter. The LED will illuminate for a maximum of 5-seconds to indicate that the unlock learn was successful. If the learn was unsuccessful the LED would continue to flash in groups of two.
4. **Release the integrated LED/Valet® switch.**



*NOTE: If the Unlock learn was unsuccessful, the Unlock procedure can be repeated by using the LOCK learn procedure, except that at step 4 press and release the integrated LED/Valet® switch TWICE. (The LED will flash in groups of two flashes.)*

## to exit the learn routine:

Do one of the following:

- Turn the ignition on.
- No activity for longer than 15 seconds.
- Press the integrated LED/Valet® switch too many times.

## on-board dual stage shock sensor

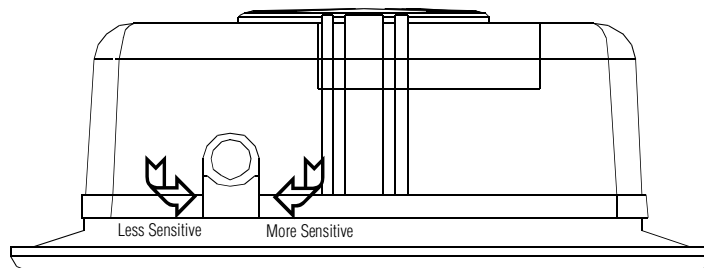

There is a dual-stage shock sensor inside the control module. Adjustments are made via the rotary control as indicated above. Since the shock sensor does not work well when mounted firmly to metal, we recommend against screwing down the control module. The full trigger of the onboard shock sensor reports zone 2. See Table of Zones.

*NOTE: When adjusting the sensor, it must be in the same mounting location that it will be after the install is completed. Adjusting the sensor and then relocating the module requires readjustment.*

## internal programming jumper

A 10A fuse is used as both a fuse and a program jumper. This jumper determines the light flash output polarity. In the (+) position, the on-board relay is enabled and the unit will output (+)12V on the WHITE wire, H1/2. In the (-) position, the on-board relay is enabled for (-) output on the WHITE wire, H1/2. To access the jumper, remove the sliding door from on top of the control module, as shown below.

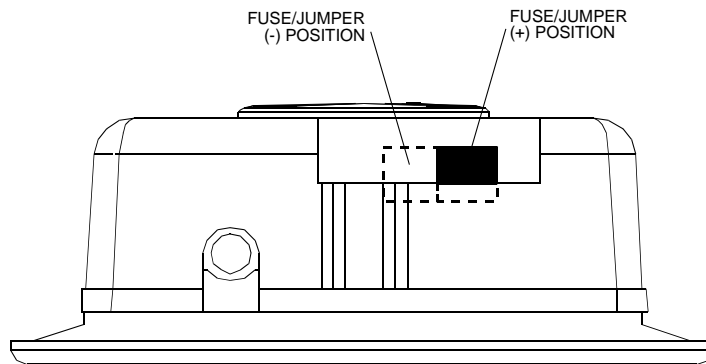

## zones

Zone Number	Trigger Type	Input Description
1	Instant trigger	Hood and/or trunk pin switches.
2	Multiplexed input	Heavy impact from on-board Doubleguard® shock sensor.
3	Two-stage, progresses from warning to full alarm	Door switch circuit.
4	Multiplexed	Optional sensor, Inputs shorter than 0.8 seconds will trigger Warn Away® response, while inputs longer than 0.8 seconds will instantly trigger full alarm.
5	Two-stage (similar to zone 3)	Ignition input.

*NOTE: The Warn Away® response does not report on the LED.*

## long term event history

The control module will store the last 2 triggers in memory that are not erased when the ignition is turned on. This can be helpful for trouble shooting false alarm reports. To access the event history use the following procedure.

1. Turn the ignition switch off and press and hold the integrated LED/Valet® switch.
2. While holding the integrated LED/Valet® switch turn the ignition On.
3. Release the integrated LED/Valet® switch.
4. Within 5-seconds, press and release the integrated LED/Valet® switch.

The LED will flash in groups indicating the last two zones reported triggered. For example, if zone 2 and 3 were the last two zones to be triggered, the LED will flash two times followed by a pause and then flash three times followed by a pause.

*NOTE: The Warn Away® response does not report on the LED.*

The Long Term Event History will exit if the ignition is turned off or there is no activity for 60-seconds.

## rapid resume logic

The current state of the alarm will be stored in non-volatile memory. If power is lost and then reconnected, the system will recall the stored state from memory (arm, dis-arm, and Valet® mode).

# feature programming

The feature programming routine is used to access and change any of the feature settings in the two menus below. The feature settings can be accessed and changed by using one of the following:

- The integrated LED/Valet® switch to enter the feature programming routine.
- Use of the Directed Electronics Bitwriter® is recommended. Expanded programming options are only available when using the Directed Electronics Bitwriter®.

*NOTE: If Feature Programming Lockout is set to ON, all features will be locked and can **ONLY** be accessed by using a Bitwriter®.*

## to enter feature programming routine

1. Open a door.
2. Turn the ignition on and then off.
3. Close the door.
4. Within 5-seconds, press and HOLD the integrated LED/Valet® switch. After 3-seconds the horn will sound once to indicate entry into the first features menu. To select the second features menu, continue to hold the integrated LED/Valet® switch until the horn sounds twice. Once the desired menu is selected, release the integrated LED/Valet® switch.
5. Within 5-seconds, press and release the integrated LED/Valet® switch the number of times corresponding to the desired feature listed below. Then press the integrated LED/Valet® switch one more time and **hold**. The horn will sound the number of times equal to the feature number selected.
6. While holding the integrated LED/Valet® switch, assign the selected feature to a factory button by either pressing Lock for 1 short horn honk setting or pressing Unlock for 2 short horn honk setting.

### once a feature is programmed

- Another feature(s) can be programmed.
- The other feature menu can be selected.
- The Learn Routine can be exited.

### accessing another feature

- Release, then press and release the integrated LED/Valet® switch the number of times to advance from the feature just programmed to the next feature desired.
- Press and **hold** the integrated LED/Valet® switch once more.
- The horn will chirp to confirm the feature selected.

### accessing another menu

- Release, then press and release **hold** the integrated LED/Valet® switch.
- After 3-seconds, the unit will advance to the next menu and the horn will sound 2 times to indicate feature menu 2 has been entered.

### exiting feature programming

- Open the door.
- Turn the ignition On.
- No activity for 15-seconds.
- Press and release the integrated LED/Valet® switch too many times.

## Bitwriter® ONLY features

Due to memory limitations for this system, the following features can only be programmed using Directed's Bitwriter® programmer. Factory default settings are shown in **bold**.

B-1	<b>Forced passive arming ON</b>	Forced passive arming OFF
B-2	<b>NPC ON</b>	NPC OFF
B-3	<b>Panic with ignition ON</b>	Panic with ignition OFF
B-4	Dealer security features ON	<b>Dealer security features OFF</b>
B-5	<b>Transmitter programming UNLOCKED</b>	Transmitter programming LOCKED
B-6	<b>Feature programming UNLOCKED</b>	Feature programming LOCKED
B-7	<b>Siren duration — 0 to 180 seconds programmable</b>	

## features #1 menu

Factory default settings are shown in **bold**.

Feature Step	Lock Button (one chirp)	Unlock Button (two chirps)
1	<b>Active arming</b>	Passive arming
2	<b>Chirps ON</b>	Chirps OFF
3	<b>Door Trigger Error Chirp ON</b>	Door Trigger Error Chirp OFF
4	<b>Ignition-Controlled Domelight ON</b>	Ignition-Controlled Domelight OFF
5	<b>Panic Enabled (OEM upgrade)</b>	Auxiliary Output Enabled (OEM upgrade)
6	<b>Auxiliary Output</b>	Delayed Accessory Output
7	<b>Delayed Door Trigger</b>	Instant Door Trigger
8	<b>Sensor shunt zones 1, 2 &amp; 4</b>	All zones
9	<b>Siren Duration–30 seconds</b>	Siren Duration–60 seconds
10	<b>Valet® switch input: 1-pulse</b>	Valet® switch input: 2-5 pulses
11	<b>Horn pulse honk duration 0.020 seconds (does not affect full trigger pulse duration)</b>	0.030, 0.040, 0.050 seconds

Feature steps 5 and 6 are related. Only if Auxiliary Output Enabled is selected in feature 5 can either Auxiliary Output or Delayed Accessory Output be selected in feature step 6. Examples of this are where Auxiliary Output is used to provide a momentary 800mSec pulse on the RED/WHITE wire of the main harness (can be used for opening the trunk). The delayed accessory output is used to allow selected vehicle accessories to remain on (such as radio) when the ignition is turned off. This output will remain active for 1 hour until a door is opened and closed, or the system is armed using the factory remote transmitter.

## features #2 menu

Factory default settings are shown in **bold**.

*NOTE: Feature step number 6 and 7 are not applicable to the this model.*

Feature Step	Lock Button (one chirp)	Unlock Button (two chirps)
1	<b>Ignition-Controlled Locking ON</b>	Ignition-Controlled Locking OFF
2	<b>Ignition-Controlled UnLocking ON</b>	Ignition-Controlled Unlocking OFF
3	<b>Active Locking</b>	Passive Locking
4	<b>Door Lock Pulse Duration–0.8 sec.</b>	Door Lock Pulse Duration–3.5 sec.
5	<b>Single Unlock Pulse</b>	Double Unlock Pulse
6	<b>Channel 3: Validity</b>	Channel 3: Second Unlock
7	<b>Code Hopping ON</b>	Code Hopping OFF



## master dealer remotes

A master dealer remote can be programmed into the system for demonstration purposes. Generally, each salesman would carry a remote that would operate all the cars on the lot equipped with this system. The dealer remotes are binary transmitters that are detuned slightly in order to limit transmitting range. The dealer remote can be taught to the system by the following Transmitter Learn Routine.

### master dealer remote learn routine

Since the OEM UPGRADE SECURITY SYSTEM does not ship with a receiver, programming of the Master Dealer Remote (Directed P/N: 465D) requires the following conditions:

- Receiver (Directed P/N: 543R and 543B) must be plugged into the 4-pin receiver port.
- 2-pin Dealer Master Loop (Included) must be plugged into the BLACK 2-pin Loop port.

*NOTE: Refer to Wiring Quick Reference Guide at the back of this guide for port locations.*

To program the Master Dealer Remote to the OEM UPGRADE SECURITY SYSTEM:

1. **Open a door.**
2. **Key.** Turn the ignition on.
3. **Choose.** Within 5-seconds, press and release the integrated LED/Valet® switch the number of times corresponding to the desired channel listed below. Once you have selected the channel, press the switch once more and HOLD it. The LED will flash and the horn will honk (if connected) to confirm the selected channel. Do not release the integrated LED/Valet® switch.
4. **Transmit.** While holding the integrated LED/Valet® switch, press the button from the transmitter that you wish to assign to the selected channel. The unit will chirp indicating successful programming. It is not possible to teach a transmitter button to the system more than once.

5. **Release.** Once the transmitter is learned, the integrated LED/Valet® switch can be released.

Channel Number	Function	Wire Color
1	Auto learn standard configuration	N/A
2 - 8	No Function for Dealer Master Remote	N/A
9	Delete all transmitters	N/A

When installing the system, it is possible to preset all of the operation settings using the master dealer remote. However, when the system is operated using the master dealer remote, a special set of dealer default settings are followed. The dealer default settings are used to ensure that every vehicle equipped with this system is protected at all times. All system features can be programmed to meet the installation needs but only the settings listed below will be affected in master dealer mode.

- Passive arming On
- Confirmation honks off
- Ignition lock and unlock on (if installed)
- Passive locking (if programmed on) ("Default setting ON for Dealer Master Mode" for passive locking.)
- Ignition domelight on
- Security features off (Programmable with Bitwriter)
- Valet® mode disabled

These features will be set as listed and will remain so (Except Security Features) until the master dealer mode is exited. Once the vehicle is delivered to the end user, the dealer master loop harness should be removed. The system will then operate according to how the operating settings have been preset. It is also possible to reprogram the operating settings by following the feature programming section of this guide.

# troubleshooting

## starter kill does not work:

- Is the correct starter wire being interrupted? If the car starts when the starter kill relay is completely disconnected, the wrong starter wire has been cut and interrupted.
- Is the yellow wire connected to "true" ignition? Make sure this wire is connected to a wire that has power in the run and start positions.

## the Valet® switch does not work.

- Is it plugged into the correct socket? See the integrated LED/Valet® Switch section.
- Is the H1/9 YELLOW wire properly connected? See Primary Harness (H1) Wire Connection Guide section of this guide.
- Was the correct hole size drilled (5/16"). See *Integrated LED/Valet® switch* section of this guide.

## status LED does not work.

- Is the LED plugged into the small white port on the side of the control unit? See integrated LED/Valet® Switch section. See *Integrated LED/Valet® switch* section of this guide.

## Passive or Ignition controlled door locks operate backwards.

- This unit has easily-reversed lock/unlock outputs. Recheck Harness 3, (+/-) Door Lock Outputs section to see if you have reversed these.

## the horn honks when the unit enters panic mode, but the confirmation honks do not work when locking and unlocking.

- Are the confirmation honks turned on in programming? See Operating Settings Learn Routine and Feature Descriptions sections.
- Is the unit in Valet mode.

## **I can get into programming and change the feature settings, but when I use the remote the settings seem to change.**

- Are you using a binary, master dealer remote? Remember, you can program the settings using a master dealer remote. However, the unit will follow the dealer default settings when using a binary remote to operate the system.

## **Door Lock Learn Routine does not learn door locks.**

- Check connections to be sure everything is properly connected. Refer to the *Keyless Entry Systems—Three Types* section of this guide for correct wire connections.
- Check the *Door Lock Learn Routine* section of this guide to ensure the correct procedure is being used.

## **Door Lock Learn Routine does not work, the unit enters the learn routine then chirps horn and exits.**

- Some cars do not flash the parking lights with the door open. For these vehicles, to program the unit correctly the door needs to be closed (so that the parking lights will flash with the factory keyless system).

## **Unit does not learn Dealer Master Remote.**

- Please refer to the *Master Dealer Remotes* section of this guide. The following two conditions must be met in order to learn a master remote:
  - A receiver (not included (543B and 543R)) MUST be connected to the system.
  - The Dealer Master Loop (included with the system) MUST be plugged in.

## **Unit goes into Programming every time the ignition is turned off.**

- The LED/Valet® switch is probably stuck in the down position. If the hole for the switch is too tight, the travel of the switch can be impaired and the switch may stick in the down position. To allow the button to travel freely, the mounting hole must not be too tight.

**Feature Programming routine does not work, the unit enters the learn routine then chirps and exits.**

- Check the Door Input connections. If the dome light is used for door trigger input, then the dome light must turn off in step 3.



# wiring quick reference guide

