

555L General Motors Passlock Interface Module

Product Description

The 555L General Motors Passlock Interface Module is used when installing remote start products in GM vehicles equipped with Passlock I and Passlock II anti-theft systems. The 555L provides easy interfacing while maintaining the integrity of the vehicle's anti-theft system. The 555L interfaces with the Passlock systems by providing the proper Resistance Code (R-Code) at the appropriate time. The 555L will also provide, when necessary, a negative signal to the bulb check wire. The 555L has no effect on the Passlock system when the remote start is not in use. The factory Passlock anti-theft system will remain fully functional.

IMPORTANT! Before beginning the installation, make sure that you are connecting to the correct type of Passlock system (either Passlock I or Passlock II). You can determine which type of system is being used by referencing the Vehicle Application Guide section in this manual.

Passlock System Details

The GM Passlock System is a key-based, fuel shutdown, anti-theft system. The Passlock system requires that the key cylinder be mechanically turned using a key. When the key cylinder is properly turned, it generates the R-Code, which is sent to the Instrument Panel Cluster (IPC) in Passlock I systems or the Body Control

Module (BCM) in Passlock II systems. The IPC and the BCM both house the Passlock decoder, which then interprets the signal.

Unlike the Passkey system, Passlock must detect the correct R-Code at the correct time. The Passlock I system uses a bulb check wire to activate the IPC module. This wire is not present in the Passlock II system. In the Passlock I system, the bulb check wire is switched to ground when the ignition switch is turned to the crank position. This initiates a time window during which the IPC analyzes the R-Code. If the R-Code is valid and received in the proper window of time, the IPC sends a code via data bus to the Powertrain Control Module (PCM) to enable the fuel system. The vehicle will then start and stay running. If the R-Code is incorrect, the vehicle will start and run for a moment and then shut off.

Passlock II also uses an R-Code, but rather than going through the IPC, the signal is sent directly to the BCM. The Passlock decoder, built into the BCM, then interprets the signal.

Passlock I Wiring Diagram

IMPORTANT! Do not attempt to use the 555L before learning the Resistance Code. (See Learning the Resistance Code section of this manual.)

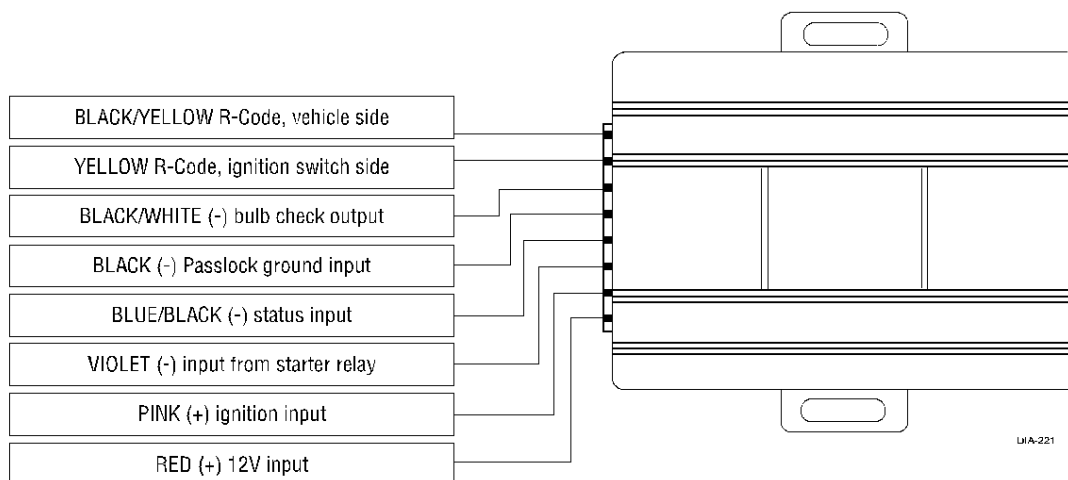

LIA-221

Wire Connection Guide for Passlock I

BLACK/YELLOW R-Code, output to vehicle side: Connect this wire to the side of the resistance wire facing away from the ignition switch. This wire is located in the vehicle's three-wire Passlock cable.

YELLOW R-Code, ignition switch: Connect this wire to the ignition switch side of the resistance wire in the three-wire Passlock cable in the vehicle.

BLACK/WHITE (-) output to bulb check wire: Connect this wire to the 20-gauge BLACK bulb check wire in the ignition switch power harness. This wire will test (-) ground only when the ignition switch is turned to the crank position. Do not connect to the black wire in the three-wire Passlock cable.

BLACK (-) Passlock ground input: Connect this input to the Passlock system's ground reference wire.

BLUE/BLACK (-) status input: Connect this wire to the (-) status output (BLUE/BLACK or BLUE) of the Directed remote start system.

VIOLET (-) input from starter relay: Connect this wire to the (-) starter output of the remote start system. This is the VIOLET ribbon harness wire of the pre-wired relay pack. To verify the correct wire, test using a digital multimeter and verify that (-) chassis ground is present on this wire while the remote start system is engaging the starter motor.

PINK (+) ignition input: Connect this wire to the heavy gauge positive (+) PINK wire of the Directed remote start system that connects to the vehicle's main ignition.

RED (+) 12 volt input: Connect this wire to a fused source of constant 12 volts.

Making Passlock I Connections

THREE-WIRE PASSLOCK CABLE

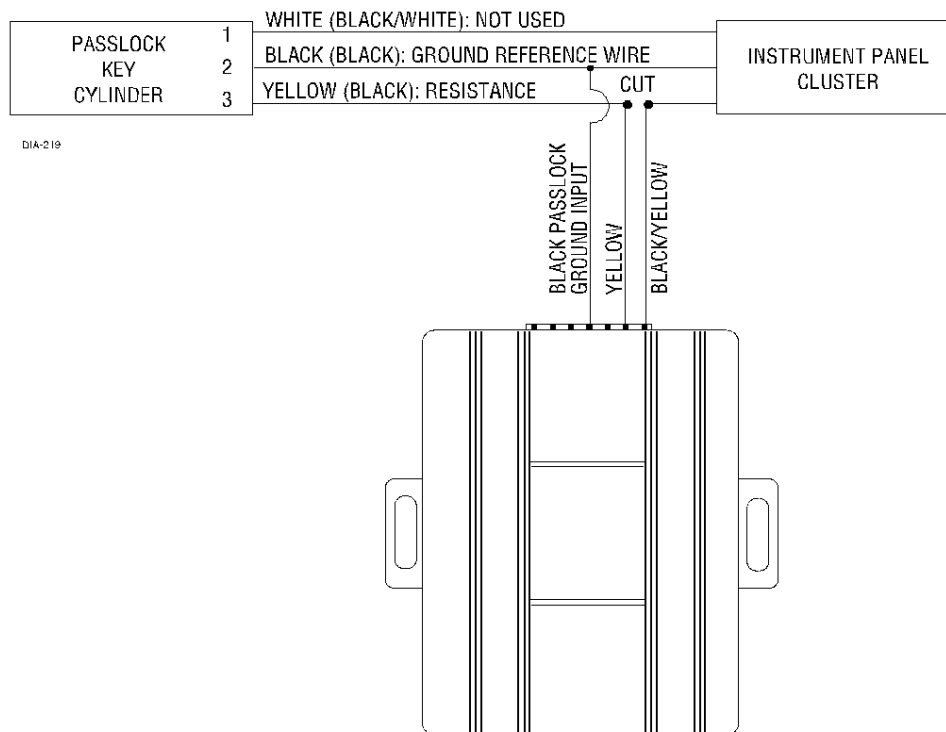

Passlock II Wiring Diagram

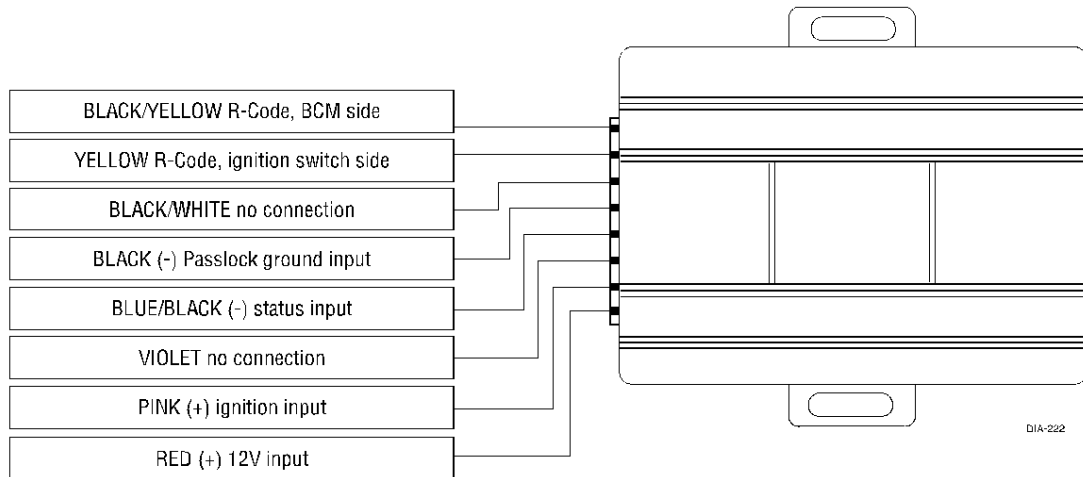

IMPORTANT! Do not attempt to use the 555L before learning the Resistance Code. (See Learning the Resistance Code section of this manual.)

Wire Connection Guide for Passlock II

BLACK/YELLOW R-Code, output to BCM: Connect this wire to the side of the resistance wire facing away from the ignition switch.

YELLOW R-Code, ignition switch: Connect this wire to the ignition switch side of the Passlock system's cut resistance wire.

BLACK/WHITE: No connection for Passlock II systems.

BLACK (-) Passlock ground input: Connect this input to the Passlock system's ground reference wire.

BLUE/BLACK (-) status input: Connect this wire to the (-) status output (BLUE/BLACK or BLUE) of the Directed remote start system.

VIOLET: No connection for Passlock II systems.

PINK (+) ignition input: Connect this wire to the heavy gauge positive (+) PINK wire of the Directed remote start system that connects to the vehicle's main ignition.

RED (+) 12 volt input: Connect this wire to a fused source of constant 12 volts.

Making Passlock II Connections

WIRES IN IGNITION HARNESS

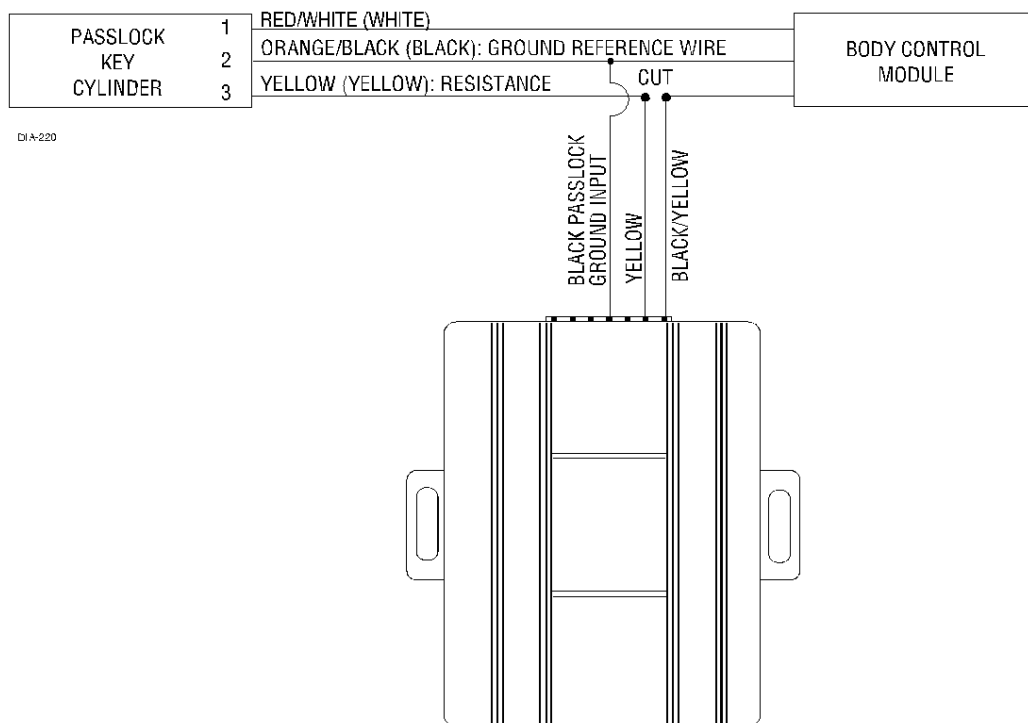

NOTE: In some Saturn vehicles that have the Passlock II system, these wires can be found in the airbag harness.

Vehicle Application Guide

MODEL YEARS	VEHICLE	PASSLOCK	GROUND	RESISTANCE	BULB CHECK
1996-1998	Achieva/Skylark	I	Black	Yellow (Black)	Yes
1995-1999	Cavalier/Sunfire	I	Black	Yellow (Black)	Yes
2000-2002	Cavalier/Sunfire	II	Black	Yellow	No
1997-1999	Cutlass	II	Black	Yellow	No
1997-2002	Malibu	II	Black	Yellow	No
1996-1998	Grand Am	I	Black	Yellow (Black)	Yes
1999-2002	Grand Am/Alero	II	Black	Yellow (Black)	No
2000-2002	Impala	II	Black	Yellow	No
1998-2002	Intrigue	II	Black	Yellow	No
2000-2002	Monte Carlo	II	Black	Yellow	No
2000-2002	Saturn S-Series	II	Black	Yellow	No
2002	Saturn Vue	II	Orange/Black	Yellow	No
2000-2002	Saturn L-Series	II	Orange/Black	Yellow	No
1998-2002	Trucks, Vans & SUVs	II	Orange/Black	Yellow	No

NOTE: The Vehicle Application Guide lists vehicles known to have the Passlock system at the time of publication of this document. GM vehicles not included in this chart may have the Passlock system. Call Directed Technical Service for details.

Learning the Resistance Code (R-Code)

After all the connections have been made:

1. Start the vehicle (with the key, not the remote start) and let the vehicle run for at least five seconds. The 555L will learn the proper R-Code.
2. Turn the ignition off.
3. Test the 555L by remote starting the vehicle. The Theft System light should illuminate briefly and then go out.

Troubleshooting Passlock 1

If the vehicle remote starts and then quickly dies, follow the below steps in order to resolve the problem.

1. Shut down the remote start
2. Is the Theft System light flashing or off? If the light is off advance to step 3. If the light is flashing advance to step 4.
3. Start the vehicle with the key.
 - If the vehicle starts make sure the BLACK wire on the 555L is soldered to the center BLACK wire of the vehicle passlock wires, also verify that the bulb check wire has been correctly identified and is soldered to the BLACK/WHITE wire of the 555L, Check the connection on the VIOLET wire of the 555L to the relay satellite ribbon harness VIOLET wire, both of these wires are required for passlock 1.
 - If the vehicle does not start and the Theft System light remains solid, recheck all connections and meter the passlock wires to verify you have interfaced with the correct wires.
4. Wait five seconds and attempt to restart the vehicle with the key. If the vehicle will not start with the key advance to step 5. If the vehicle starts and stays running, recheck all connections. The vehicle has entered Short Tamper mode caused by a failure of the passlock module to read the R-code within the time window allowed, verify that the blue/black off the 555L is seeing a ground trigger when remote started, and is soldered to the Blue status output from the remote start unit. If 3 attempts are made to start the vehicle in which no R-code is read the passlock system will enter Long Tamper mode
5. The system has entered Long Tamper mode, this mode will not allow the vehicle to start for 10 minutes, long tamper mode is almost always caused by the wrong R-code being sent to the passlock module. This will immediately cause a No-Start condition, even if an attempt is made to start the vehicle with the key, In this case wait 10 minutes and reattempt to learn the R-code after all connections have been verified.

Troubleshooting Passlock 2

If the vehicle remote starts and then quickly dies, follow the below steps in order to resolve the problem.

1. Shut down the remote start.
2. Is the Theft System light flashing or off? If the light is off advance to step 3. If the light is flashing advance to step 4.
3. Start the vehicle with the key.
 - If the vehicle starts, use a meter to confirm that the correct wires have been interfaced. Verify all connections and make sure the BLACK wire on the 555L is soldered to the ORANGE/BLACK or BLACK wire of the vehicle passlock wires. Then verify that the VIOLET and BLACK/WHITE wires from the 555L are NOT connected to anything, the YELLOW goes to the key cylinder side of the yellow passlock wire, and the BLACK/YELLOW goes to the car side of the YELLOW passlock wire.
 - If the vehicle does not start with the key advance to step 4.
4. Wait five seconds, then attempt to start the vehicle with the key.
 - If the vehicle will not start with the key advance to step 5.
 - If the vehicle starts and stays running, recheck all connections. The vehicle has entered the Short Tamper mode. This is caused by a failure of the passlock module to read the R-code within the time window allowed. Verify that the BLUE/BLACK wire off the 555L is seeing a ground trigger when remote started and is soldered to the BLUE status output from the remote start unit. If three attempts are made to start the vehicle in which no R-code is read the passlock system will enter Long Tamper mode.
5. The system has entered Long Tamper mode. This will not allow the vehicle to start for 10 minutes. Long tamper mode is almost always caused by the wrong R-code being sent to the passlock module. This will immediately cause a No-Start condition, even if an attempt is made to start the vehicle with the key. In this case wait 10 minutes and reattempt to learn the R-code after all connections have been verified.