

457G GM DATA BUS INTERFACE

IMPORTANT! Please read this installation guide thoroughly before installing the 457G. Use only a high quality digital multi-meter for testing. This product connects to the vehicle's low voltage signal wire and improper installation or testing can result in damage to the vehicle. Never use a test light or logic probe to test wires in this vehicle!

The 457G interfaces with specific GM vehicles. It converts the signals from the keyless entry, alarm, or remote start into signals that can be understood by the vehicles factory Data Bus system. This allows for interfacing with various factory options such as factory alarms. The 457G also interfaces with Passlock II and PassKey III systems.

NOTE: The trunk release feature is not available on all platforms.

wiring diagram—main harness

WARNING: Do not connect the Gray/Black or Green wires when installing in a vehicle with a manual transmission and remote start. Bodily injury or property damage could occur.

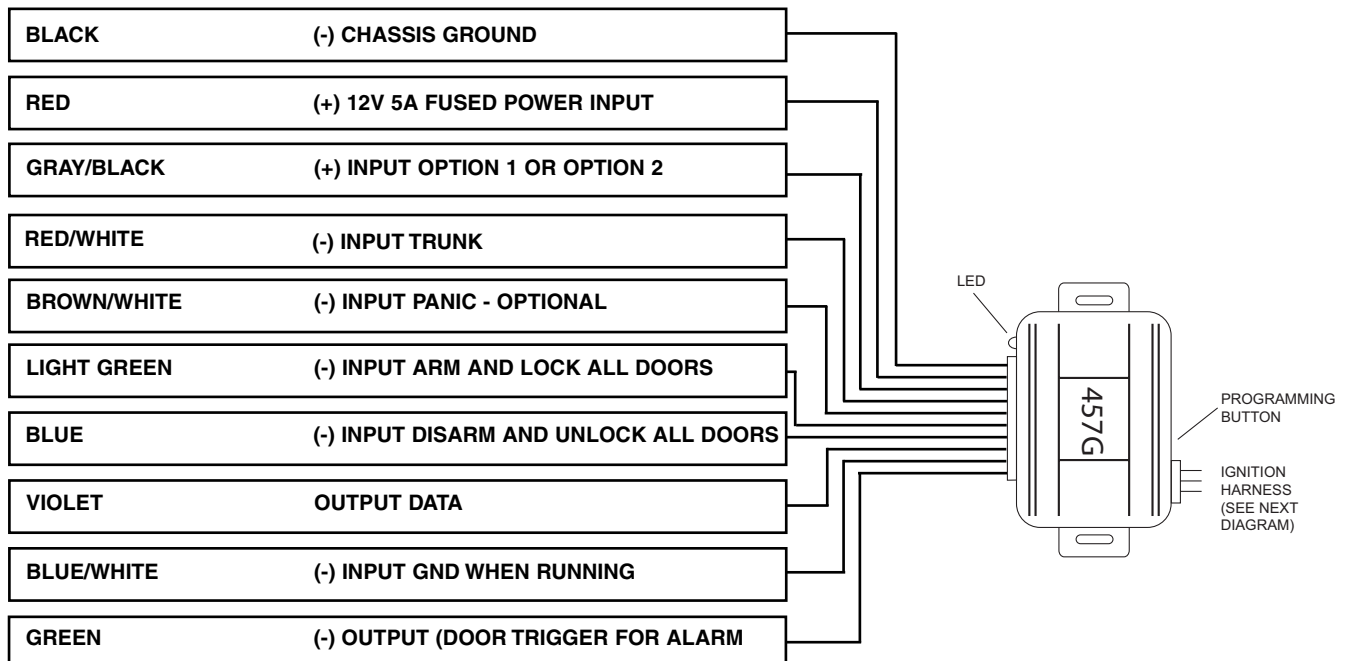

ignition harness

The Ignition Harness is to be wired only for the Cadillac models listed below, or if the Security Light illuminates after a start.

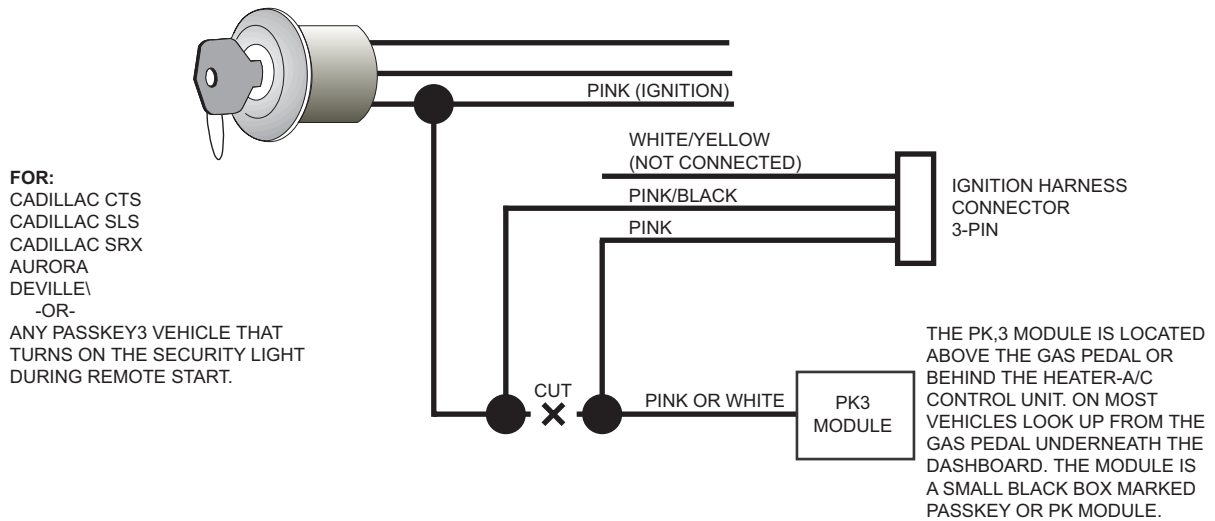

wire connection guide - main harness

WIRE	DESCRIPTION
BLACK	Remove any paint from the connection area and connect this wire to bare metal, preferably in the driver's kick panel. Do not use the steering column or underdash bracing.
RED	Connect this wire to a constant 12V power source located at the ignition or battery terminal.
GRAY/BLACK	Option 1 - Connect this wire to the vehicle's positive dome light circuit. Option 2 - Connect this wire to the (+) ignition on vehicles that use PK3.
RED/WHITE	Connect this wire to the Auxiliary Channel output from the alarm system to open the trunk (not available on all platforms).
BROWN/WHITE	Connect this wire to an Auxiliary Channel output from the alarm system to use the vehicle's factory panic alarm.
LIGHT GREEN	Connect this wire to the negative Lock wire from the aftermarket alarm system.
BLUE	Connect this wire to the negative Unlock wire from the aftermarket alarm system.
VIOLET	Connect this wire to the Violet wire at the diagnostic plug (see figure below).
BLUE/WHITE	Connect this wire to a wire that goes to ground and stays at ground the whole time the vehicle is in remote start mode. In Directed systems this wire is Blue or Blue/White (status output).
GREEN	Connect this wire to the negative door trigger input for aftermarket alarm systems. In Directed systems this wire is Green.

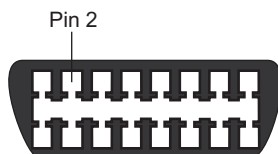

Diagnostic plug—view from the front
 Located below the dash—driver's side

wire connection guide - ignition harness

WIRE	DESCRIPTION
WHITE/YELLOW	Not used.
PINK/BLACK	Connect this wire to the ignition switch side of the ignition wire at the PassKey module.
PINK	Connect this wire to the module side of the ignition wire at the PassKey module.

Programming

1. Locate and press the programming switch while inserting the wire harness into connector 1 of the GM DATA ALL module. The LED status indicator will illuminate to indicate the system is in programming mode. Keep the programming button pressed while turning the ignition to ON. Release the programming switch once the LED status indicator flashes rapidly.
2. Start the engine (using the vehicle's key). The LED status indicator will turn off to indicate that the module has been programmed for either PassKeyIII or PassLockII (and control of additional features where applicable). Turn the key to the OFF position.

car list

MODEL	YEAR
Bravada	1999, 2000, 2001, 2002, 2003, 2004
Envoy	1999, 2000, 2001, 2002, 2003, 2004
Trailblazer	1999, 2000, 2001, 2002, 2003, 2004
Avalanche	1999, 2000, 2001, 2002, 2003, 2004
Escalade	1999, 2000, 2001, 2002, 2003, 2004
C/K Pickup	1999, 2000, 2001, 2002, 2003, 2004
Silverado	1999, 2000, 2001, 2002, 2003, 2004
Sierra	1999, 2000, 2001, 2002, 2003, 2004
Suburban	1999, 2000, 2001, 2002, 2003, 2004
Tahoe	1999, 2000, 2001, 2002, 2003, 2004
Yukon (all)	1999, 2000, 2001, 2002, 2003, 2004
Hummer	1999, 2000, 2001, 2002, 2003, 2004
Aurora	2000, 2001, 2002, 2003, 2004
SRX	2004
CTS	2003, 2004
Deville	2000, 2001, 2002, 2003, 2004
Le Sabre	2000, 2001, 2002, 2003, 2004
Bonneville	2000, 2001, 2002, 2003, 2004
Park Avenue	2000, 2001, 2002, 2003, 2004
SLS	2000, 2001, 2002, 2003, 2004
STS	2000, 2001, 2002, 2003, 2004
Alero	2000, 2001, 2002, 2003, 2004
Astro	1998, 1999, 2000, 2001, 2002, 2003, 2004
Blazer	1998, 1999, 2000, 2001, 2002, 2003, 2004
Cavalier	2000, 2001, 2002, 2003, 2004
Express Van	1998, 1999, 2000, 2001, 2002, 2003, 2004
Grand Am	1999, 2000, 2001, 2002, 2003, 2004
Impala	2000, 2001, 2002, 2003, 2004
Intrique	1999, 2000, 2001, 2002, 2003
Monte Carlo	2000, 2001, 2002, 2003, 2004
S-10	1999, 2000, 2001, 2002, 2003
Safari	1998, 1999, 2000, 2001, 2002, 2003, 2004
Saturn Series S	2000, 2001, 2002, 2003
Savana	1998, 1999, 2000, 2001, 2002, 2003, 2004
Sonoma	1998, 1999, 2000, 2001, 2002, 2003
Sunfire	2000, 2001, 2002, 2003, 2004
Astek	2002, 2003, 2004
Grand Prix	not compatible
Montana	2000, 2001, 2002, 2003, 2004
Rendez-vous	2002, 2003, 2004
Silhouette	2000, 2001, 2002, 2003, 2004
Venture	2000, 2001, 2002, 2003, 2004