

DIRECTED®

**RF KIT TYPE:
9474, 9143, 9145, 9146**

**4-button ASK remotes:
474, 7143, 7145, 7146**

User's Guide

© 2016 Directed, Vista, CA
GRFASK4 2016-10

FailSafe®, Learn Routine™, Silent Mode™, Valet®, and Warn Away®
are all Trademarks or Registered Trademarks of Directed®.

Table of Contents

Congratulations	3
Important information	3
Introduction	4
Antenna	4
Remote Control Pairing with XL202	5
Compatibilities	5
Remote Control Pairing with a 4X10/5X10 System	6
Basic Commands	7
Lock	7
Unlock	7
Remote Start	7
AUX/Trunk	7
Remote Start Features	8
Key Takeover	8
Safety Features	8
Pit Stop	8
Optional Rear Defogger	9
Disabling the Remote Start System	9
Rapid Resume Logic	10
Battery Information	10
Battery Replacement	10
Battery Disposal	10
Patent Information	11
Government Regulations	12
Warning! Safety First	14
Limited One Year Consumer Warranty	15

Congratulations

Congratulations on the purchase of your state-of-the-art Directed Digital System. Reading this Owner's Guide prior to using your system will help maximize the use of it and its many features. For any additional questions please contact your authorized Directed dealer or Directed at **1-800-753-0600**. Additional support is also available at: <http://support.directed.com>

Important information

Government Regulations and Safety information



Read the **Government Regulations** and **Warning! Safety First** sections of this manual prior to operating this system.

Warning! Failure to heed this information can result in death, personal injury or property damage and may also result in the illegal use of the system beyond its intended purpose.

Your Warranty

Your system comes with a warranty. The warranty terms are detailed at the end of this guide. Make sure that you receive the proof of purchase from your dealer, indicating the product was installed by an authorized Directed dealer.

Replacement remote controls

Please see your authorized dealer or visit us at www.directedstore.com to order additional remote controls. Remote control RPN (Replacement Part Number) are typically found on the back of the device.

Introduction

Antenna



In-vehicle System Antenna

The in-vehicle system antenna, typically located on the upper part of the front windshield sends and receives commands or messages to and from your system.

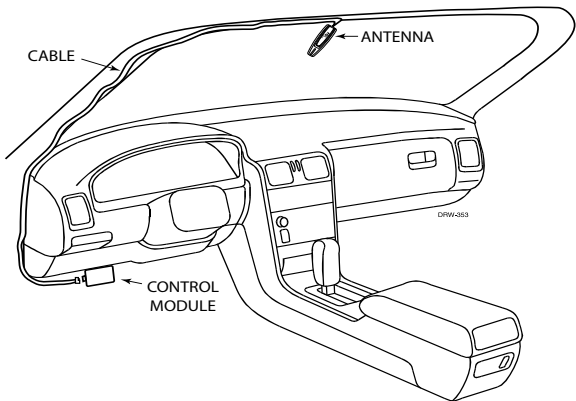

Remote Control Pairing with XL202

Once this Antenna has been installed, you must pair the remote with the system. Use the following procedure to pair the XL202 with the remote control.

Compatibilities

RF Kit Part #	Included in RF Kit (XL202 not included)		XL202 Firmware
	Remote Part #	Antenna Part #	
9474, 9143, 9145, 9146	(2) 1-way 474, 7143, 7145, 7146	6102T	202.RFTDKLQ1

Find the XL202 (control module) located under the driver's side dash and proceed with the programming steps.

- 1** Press and **hold** the Programming button of the XL202 module. The LED flashes slowly.



- 2** Press the Lock button on the remote. The LED on the XL202 turns ON solid for one second, then turns OFF to indicate the pairing was completed successfully.



- 3** When programming of every remote is completed, **release** the Programming button on the XL202.



Note: Exiting Pairing Mode

The XL202 Learn Routine exits if the programming button is released.

Remote Control Pairing with a 4X10/5X10 System

Find the Valet button usually located under the driver's side dash and the status LED, then proceed with the programming steps.

- 1 Open at least one vehicle door.



- 2 Turn the ignition to the ON position.



- 3 Within 10 seconds, **press** and **release** once and then **press** and **hold** the system's Valet button. The status LED begins flashing in a sequence of 1 flash and the siren/horn (if connected) sounds to confirm the system is ready for pairing.

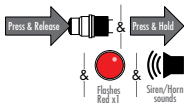

- 4 **Press** and **release** the Lock button on the remote. The vehicle horn sounds (if connected) to confirm the system has paired with the remote control. If Remote Pairing fails, repeat the above procedure or confirm the firmware flashed to the 4X10/5X10 is correct for the type Antenna/Remote being used.



- 5 **Release** the Valet button and **Turn** the ignition OFF.



Note: Exiting Pairing Mode

The 4X10/5X10 Learn Routine exits if any of the following occurs:

- The ignition is turned OFF.
- There is no activity for 60 seconds.
- The Program button is pressed too many times.

Basic Commands

Lock

Press and release 

The doors lock (if connected) and parking lights or hazard lights flash once.

Unlock

Press and release 

The doors unlock (if connected) and parking lights or hazard lights flash twice.

Remote Start

Press and release 

Activates (or if ON, deactivates) the remote starter. The engine and parking lights or hazard lights turn ON, or the engine and parking lights or hazard lights turn OFF. The runtime on the remote starter is predetermined based on vehicle application. The remote starter will shut down when the preset runtime times out or when any shutdown zone becomes active.

AUX/Trunk

Press and hold  or 

The Trunk or rear hatch opens (if connected) when this button is pressed and held for 5 seconds.

Remote Start Features

Key Takeover

When you are ready to drive the vehicle:

1. **Unlock** the doors
2. **Enter** the vehicle. **DO NOT** step on the foot brake
3. **Insert** the key, **turn** it to the run (not start) position. **Step on** the foot brake. The remote start is disabled and the parking lights turn OFF.
4. **Begin** driving.

Note	If your vehicle uses a Smart Key or PTS (Push-To-Start) system, please refer to the vehicle specific instructions included with the owner's guide of the interface module or consult your authorized dealer.
-------------	--

Safety Features

The following safety features will disable the remote start when activated or not allow the engine to start if not properly set before starting.

- Foot Brake is depressed.
- Hood is open.
- Shut down toggle switch is OFF.
- The pre-programmed runtime has elapsed.
- The remote start button is pressed while the vehicle is already running.

Pit Stop

This remote start can keep the engine running during short trips away from the vehicle.

Enabling Pit Stop mode

1. **Park** in a well ventilated area.
2. With the engine running **set** the transmission in the park position.
3. **Press** and **release** the remote control button, the parking lights turn ON to confirm remote start is ON.
4. **Turn** OFF the ignition and **remove** the key, the engine continues running.
5. **Exit** the vehicle and lock the doors, the engine runs for the programmed runtime.

Note Pit Stop mode does not work if the brake pedal is pressed. If your vehicle uses a Smart Key or PTS (Push-To-Start) system, please refer to the vehicle specific instructions included with the owner's guide of the interface module or consult your authorized dealer.

Optional Rear Defogger

If connected, the Defogger circuit automatically activates after remote starting the vehicle.

Note This feature is only available with 4X10/5X10 system.

Disabling the Remote Start System

When the Shutdown Switch is set to the OFF position, remote engine starting is defeated. DO this when the vehicle is being serviced or driven by someone unfamiliar with remote start system operations.

Location Of Shutdown Switch: _____

Rapid Resume Logic

This Directed system stores its current state to non-volatile memory. If power is lost and then reconnected the system recalls the stored state from memory.

Battery Information

The remote control is powered by two batteries (RPN* CR-2016). These can be purchased at most retailers. When the battery begins to weaken, the LED on the remote control dims and the operating range is reduced.

Battery Replacement

1. If present, **remove** the small screw on the back of the remote
2. Use a small flat blade screwdriver and **insert** it into the slot located along the bottom of the remote, near the key ring. Carefully **pry** open the case.
3. Gently **slide** out the used battery to remove it from the holding clip. **Orient** the new battery for the correct polarity and **insert** into holding clip.
4. **Reposition** case parts, and **snap** together by pressing firmly and evenly on the front and back. **Reinstall** screw (if applicable).
5. Test remote functions.

Battery Disposal



Directed cares about the environment. If you need to dispose of the battery, please do so in accordance with your municipal requirements for battery disposal.

* RPN (Replacement Part Number).

Patent Information

This product is covered by one or more of the following United States patents:

Remote Start Patents:

5,349,931; 5,872,519; 5,914,667; 5,952,933;
5,945,936; 5,990,786; 6,028,372; 6,467,448;
6,561,151; 7,191,053; 7,483,783

Vehicle Security Patents:

5,467,070; 5,532,670; 5,534,845; 5,563,576; 5,646,591;
5,650,774; 5,673,017; 5,712,638; 5,872,519; 5,914,667;
5,952,933; 5,945,936; 5,990,786; 6,028,505; 6,452,484

Other patents pending.

Government Regulations

This device complies with Part 15 of FCC rules. Operation is subject to the following two conditions: (1) This device may not cause harmful interference, and (2) This device must accept any interference received, including interference that may cause undesirable operation.

This equipment has been tested and found to comply with the limits for a Class B digital device, pursuant to Part 15 of the FCC Rules. These limits are designed to provide reasonable protection against harmful interference in a residential installation. This equipment generates and can radiate radio frequency energy and, if not installed and used in accordance with the instruction manual, may cause harmful interference to radio communications. However, there is no guarantee that interference will not occur in a particular installation. If this equipment does cause harmful interference to radio or television, which can be determined by turning the equipment OFF and ON, the user is encouraged to try to correct the interference by one or more of the following measures:

- Reorient or relocate the receiving antenna.
- Increase the separation between the equipment and receiver.
- Connect the equipment into an outlet on a circuit different from that to which the receiver is connected.
- Consult the dealer or an experienced radio / TV technician for help.

Remote Controls

To satisfy FCC RF exposure compliance requirements, this device should be used in hand-held, hand operated configurations only. The device and its antenna must maintain a separation distance of 20 cm or more from the person's body, except for the hand and wrists, to satisfy RF exposure compliance. This device is designed to be used in a person's hands and its operating configurations do not support normal transmissions while it is carried in pockets or holsters next to a person's body.

Antenna

To satisfy FCC RF exposure compliance requirements, the device and its antenna must maintain a separation distance of 20 cm or more from the person's body, except for the hand and wrists, to satisfy RF exposure compliance.

This device complies with the Industry Canada Radio Standards Specification RSS 210. Its use is authorized only on a no-interference, no-protection basis; in other words, this device must not be used if it is determined that it causes harmful interference to services authorized by IC. In addition, the user of this device must accept any radio interference that may be received, even if this interference could affect the operation of the device.

WARNING! Changes or modifications not expressly approved by the party responsible for compliance could void the user's authority to operate this device.

Warning! Safety First



Please read the safety warnings below before proceeding. Improper use of the product may be dangerous or illegal.

Installation

Due to the complexity of this system, installation of this product must only be performed by an authorized Directed dealer. If you have any questions, ask your retailer or contact Directed directly at **1-800-753-0600**.

Remote Start Capable

When properly installed, this system can start the vehicle via a command signal from the remote control transmitter. Therefore, never operate the system in an enclosed area or partially enclosed area without ventilation (such as a garage). When parking in an enclosed or partially enclosed area or when having the vehicle serviced, the remote start system must be disabled using the installed menu wheel. It is the user's sole responsibility to properly handle and keep out of reach from children all remote control transmitters to assure that the system does not unintentionally remote start the vehicle. THE USER MUST INSTALL A CARBON MONOXIDE DETECTOR IN OR ABOUT THE LIVING AREA ADJACENT TO THE VEHICLE. ALL DOORS LEADING FROM ADJACENT LIVING AREAS TO THE ENCLOSED OR PARTIALLY ENCLOSED VEHICLE STORAGE AREA MUST AT ALL TIMES REMAIN CLOSED. These precautions are the sole responsibility of the user.

Interference

All radio devices are subject to interference which could affect proper performance.

Upgrades

Any upgrades to this product must be performed by an authorized Directed dealer. Do not attempt to perform any unauthorized modifications to this product.

Water/Heat Resistance

This product is not designed to be water and/or heat-resistant. Please take care to keep this product dry and away from heat sources. Any damage from water or heat will void the warranty.

Limited One Year Consumer Warranty

For a period of ONE YEAR from the date of purchase of a Directed Electronics remote start or security product, Directed Electronics. ("DIRECTED") promises to the original purchaser, to repair or replace with a comparable reconditioned piece, the security or remote start accessory piece (hereinafter the "Part"), which proves to be defective in workmanship or material under normal use, provided the following conditions are met: the Part was purchased from an authorized DIRECTED dealer; and the Part is returned to DIRECTED, postage prepaid, along with a clear, legible copy of the receipt or bill of sale bearing the following information: consumer's name, address, telephone number, the authorized licensed dealer's name and complete product and Part description. This warranty is nontransferable and is automatically void if the Part has been modified or used in a manner contrary to its intended purpose or the Part has been damaged by accident, unreasonable use, neglect, improper service, installation or other causes not arising out of defect in materials or construction.

TO THE MAXIMUM EXTENT ALLOWED BY LAW, EXCEPT AS STATED ABOVE, ALL WARRANTIES, INCLUDING BUT NOT LIMITED TO EXPRESS WARRANTY, IMPLIED WARRANTY, WARRANTY OF MERCHANTABILITY, FITNESS FOR PARTICULAR PURPOSE AND WARRANTY OF NONINFRINGEMENT OF INTELLECTUAL PROPERTY, ARE EXPRESSLY EXCLUDED; AND DIRECTED NEITHER ASSUMES NOR AUTHORIZES ANY PERSON OR ENTITY TO ASSUME FOR IT ANY DUTY, OBLIGATION

OR LIABILITY IN CONNECTION WITH ITS PRODUCTS. DIRECTED HEREBY DISCLAIMS AND HAS ABSOLUTELY NO LIABILITY FOR ANY AND ALL ACTS OF THIRD PARTIES INCLUDING DEALERS OR INSTALLERS. DIRECTED IS NOT OFFERING A GUARANTEE OR INSURANCE AGAINST VANDALISM, DAMAGE, OR THEFT OF THE AUTOMOBILE, ITS PARTS OR CONTENTS, AND DIRECTED HEREBY DISCLAIMS ANY LIABILITY WHATSOEVER, INCLUDING WITHOUT LIMITATION, LIABILITY FOR THEFT, DAMAGE, OR VANDALISM. IN THE EVENT OF A CLAIM OR A DISPUTE INVOLVING DIRECTED OR ITS SUBSIDIARY, THE PROPER VENUE SHALL BE SAN DIEGO COUNTY IN THE STATE OF CALIFORNIA. CALIFORNIA STATE LAWS AND APPLICABLE FEDERAL LAWS SHALL APPLY AND GOVERN THE DISPUTE. THE MAXIMUM RECOVERY UNDER ANY CLAIM AGAINST DIRECTED SHALL BE STRICTLY LIMITED TO THE AUTHORIZED DIRECTED DEALER'S PURCHASE PRICE OF THE PART. DIRECTED SHALL NOT BE RESPONSIBLE FOR ANY DAMAGES WHATSOEVER, INCLUDING BUT NOT LIMITED TO, ANY CONSEQUENTIAL DAMAGES, INCIDENTAL DAMAGES, DAMAGES FOR THE LOSS OF TIME, LOSS OF EARNINGS, COMMERCIAL LOSS, LOSS OF ECONOMIC OPPORTUNITY AND THE LIKE. NOTWITHSTANDING THE ABOVE, THE MANUFACTURER DOES OFFER A LIMITED WARRANTY TO REPLACE OR REPAIR AT DIRECTED'S OPTION THE PART AS DESCRIBED ABOVE.

This warranty only covers Parts sold within the United States of America and Canada. Parts sold outside of the United States of America or Canada are sold "AS-IS" and shall have NO WARRANTY, express or implied. Some states do not allow limitations on how long an implied warranty will last or the exclusion or limitation of incidental or consequential damages. This warranty gives you specific legal rights and you may also have other rights that vary from State to State. DIRECTED does not and has not authorized any person or entity to create for it any other obligation, promise, duty or obligation in connection with this Part. For further details relating to warranty information of Directed products, please visit the support section of DIRECTED's website at: www.directed.com

The company behind this system is Directed

Since its inception, Directed has had one purpose, to provide consumers with the finest vehicle security and accessories available. The recipient of nearly 100 patents and Innovations Awards in the field of advanced electronic technology.

Quality Directed products are sold and serviced throughout North America and around the world.

Call (800)274-0200 for more information about our products and services.

Directed is committed to delivering world class quality products and services that excite and delight our customers.

DIRECTED®

Vista, CA 92081

www.directed.com

© 2016 Directed—All rights reserved

GRFASK4 2016-10