



Model 3100L

Installation Guide



table of contents

What Is Included	2	Plug-In LED and Valet/Program Switch	17
Wiring Quick Reference Guide	3	Internal Programming Jumper	18
Primary Harness (H1) Wire Connection Guide	4	On-Board Dual Stage Zone 2 Impact Sensor	19
Door Lock Harness (H2) Wire Connection Guide	8	Bypassing Sensor Inputs	19
Type A Door Locks: Positive-Triggered, Relay Driven Systems	9	Transmitter/Receiver Remote Control Code Learning	20
Type B Door Locks: Negative-Triggered, Relay Driven Systems (Type B)	10	Transmitter Configuration	21
Type C Door Locks: Reversing Polarity Systems	11	Operating Settings Remote Control Code Learning	22
Type D Door Locks: Adding One or More After-Market Actuators.	12	Features Menu	23
Type E Door Locks: Electrically Activated Vacuum	13	Feature Descriptions	24
Type F Door Locks: One-Wire System	14	Nuisance Prevention Circuitry ®	25
Type G Door Locks: Positive (+) Multiplex.	15	Table of Zones	25
Type H Door Locks: Negative (-) Multiplex	16	Troubleshooting	26
Starter Interrupt Harness (H3) Wire Connection Guide	17		

Avital®, Bitwriter™, DEI®, Doubleguard®, ESP™, FailSafe®, Ghost Switch™, Learn Routine™, Nite-Lite®, Nuisance Prevention Circuitry®, NPC®, Revenger®, Silent Mode™, Soft Chirp®, Stinger®, Valet®, Vehicle Recovery System®, VRS®, and Warn Away® are all Trademarks or Registered Trademarks of Directed Electronics, Inc.

what is included

- The control module
- Two 3-button remote transmitters
- The plug-in LED system status indicator
- The plug-in Valet/Program switch
- An on-board zone 2 impact sensor
- A high-powered siren
- The 12-pin primary harness
- The 3-pin door lock harness
- The plug-in starter interrupt harness

wiring quick reference guide

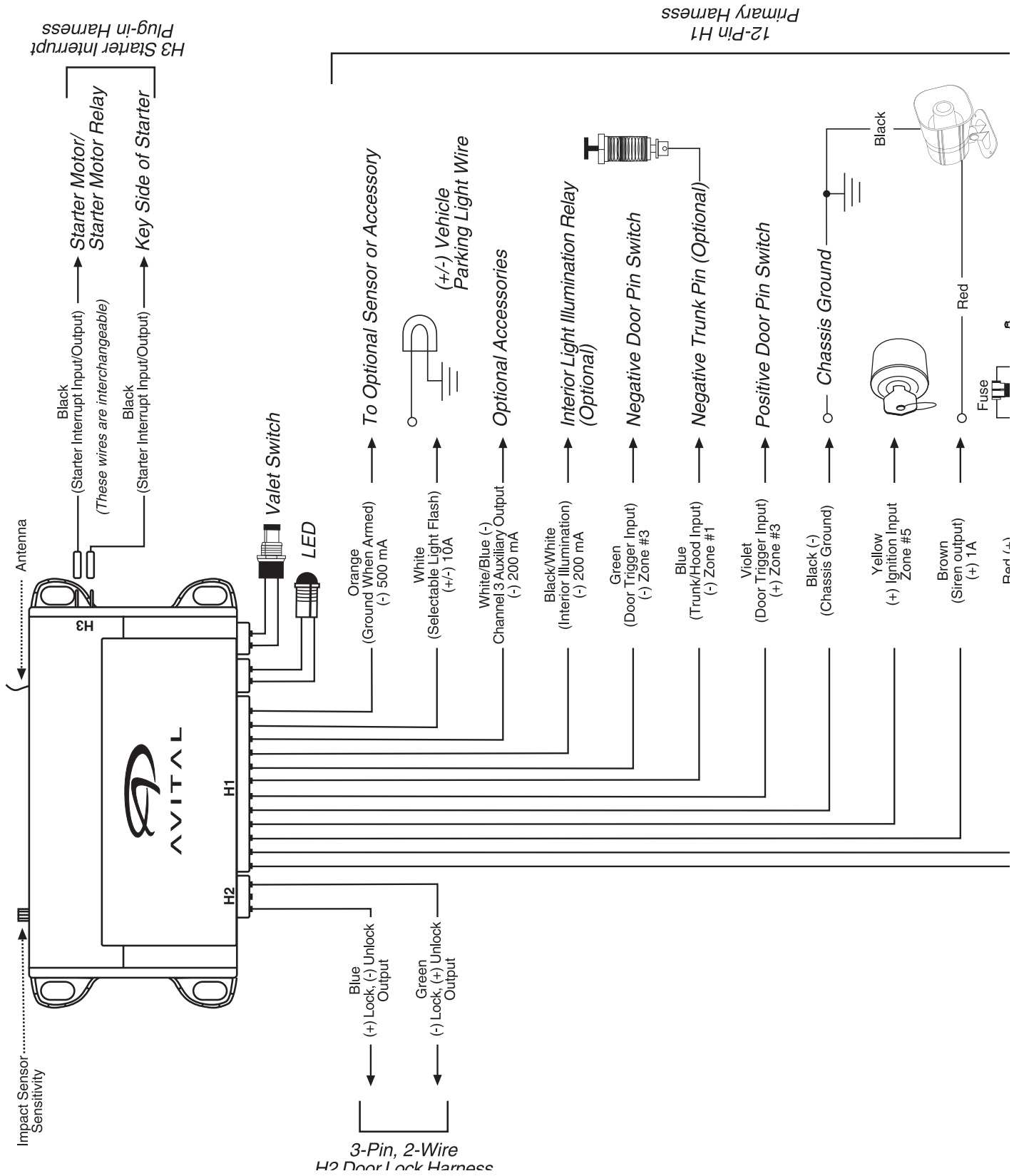

primary harness (H1) wire connection guide

H1/1	ORANGE	(-) 500 mA GROUND-WHEN-ARMED OUTPUT
H1/2	WHITE	(+/-) SELECTABLE LIGHT FLASH OUTPUT
H1/3	WHITE/BLUE	(-) 200 mA CHANNEL 3 VALIDITY OUTPUT
H1/4	BLACK/WHITE	(-) 200 mA INTERIOR LIGHT ILLUMINATION OUTPUT
H1/5	GREEN	(-) DOOR TRIGGER INPUT, ZONE 3
H1/6	BLUE	(-) MULTIPLEX TRIGGER INPUT, ZONE 1
H1/7	VIOLET	(+) DOOR TRIGGER INPUT, ZONE 3
H1/8	BLACK	(-) CHASSIS GROUND INPUT
H1/9	YELLOW	(+) IGNITION INPUT, ZONE 5
H1/10	BROWN	(+) SIREN OUTPUT
H1/11	RED	(+) 12V CONSTANT POWER INPUT
H1/12	RED/WHITE	(-) 200 mA CHANNEL 2 VALIDITY OUTPUT

H1/1 ORANGE (-) ground-when-armed 500 mA output

This wire supplies (-) ground as long as the system is armed. This output ceases as soon as the system is disarmed. It can be used to turn on an optional sensor or to control an optional accessory, such as a window module or pager.

H1/2 WHITE (+/-) selectable light flash output

As shipped, this wire should be connected to the (+) parking light wire. If the light flash polarity jumper inside the control module is moved to the opposite position (see *Internal Programming Jumper* section of this guide), this wire supplies a (-) 200 mA output. This is suitable for driving (-) light control wires in Toyota, Lexus, BMW, some Mitsubishi, some Mazda, and other model cars.

(+) Positive Light Flash Output

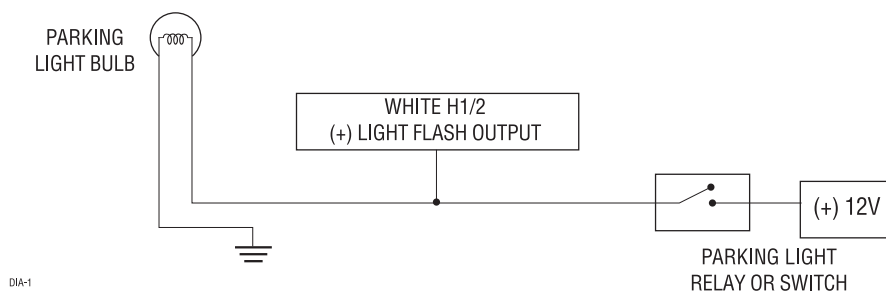

(-) Negative Light Flash Output

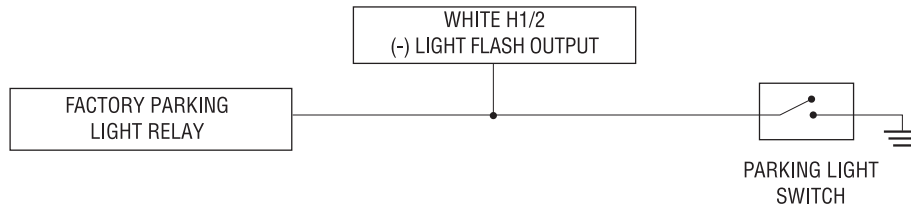

NOTE: For parking light circuits that draw 10 amps or more, the internal jumper must be switched to a (-) light flash output. (See the Internal Programming Jumper section of this guide.) **P/N 8617** or a standard automotive SPDT relay must be used on the H1/2 light flash output harness wire.

H1/3 WHITE/BLUE (-) channel 3 output

This wire provides a (-) 200 mA output whenever the transmitter code controlling Channel 3 is received. This output will continue as long as that transmission is received. Use for options such as **551T** Valet® Start system, **529T** or **530T** power window controllers, etc.

IMPORTANT! Never use this wire to drive anything except a relay or a low-current input! The transistorized output can only provide 200 mA of current, and connecting directly to a solenoid, motor, or other high-current device will cause it to fail.

H1/4 BLACK/WHITE (-) interior light illumination output

Connect the H1/4 BLACK/WHITE wire to an optional relay for interior light illumination (**p/n 8617** or standard automotive SPDT relay).

IMPORTANT! This output is only intended to drive a relay. It cannot be connected directly to the domelight circuit, as the output is not able to support the current draw of one or more light bulbs.

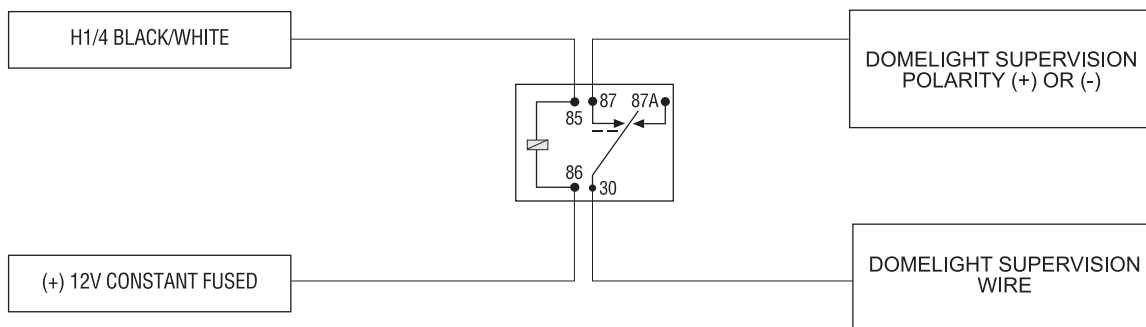

H1/5 GREEN (-) door trigger input, zone 3

Most vehicles use negative door trigger circuits. Connect the green wire to a wire which shows ground when any door is opened. In vehicles with factory delays on the domelight circuit, there is usually a wire that is unaffected by the delay circuitry. This wire will report Zone 3.

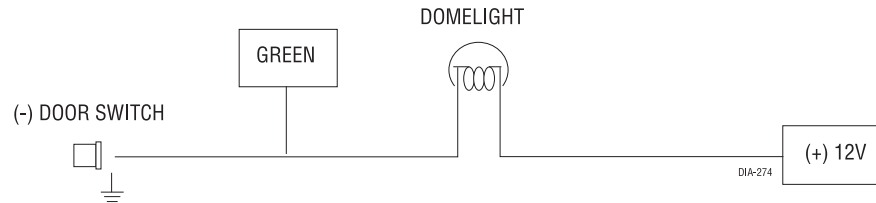

H1/6 BLUE (-) multiplex trigger input, zone 1

This wire will respond to a negative input with an instant trigger. Inputs shorter than 0.8 seconds will trigger the Warn Away response, while triggers longer than 0.8 seconds will instantly trigger the full alarm cycle. This wire is ideal for hood and trunk pins and will report on Zone 1. This wire can also be used with DEI's 506T Glass Breakage Sensor, as well as other DEI single stage sensors.

The H1/6 BLUE multiplex trigger wire can be used to shunt sensors during operation, using the auxiliary channels. When any of the auxiliary channels are transmitted, the H1/6 BLUE wire monitors for a ground. If ground is detected within 5 seconds of transmission, the sensors and the multiplex trigger input on the BLUE wire will be shunted until 5 seconds after the ground is removed. This allows the customer to access the trunk, remote start the vehicle, or roll the windows down without first disarming the alarm. (See *Bypassing Sensor Inputs* section of this guide.)

H1/7 VIOLET (+) door trigger input, zone 3

This wire is used in vehicles that have a positive (+) switched dome light circuit. Connect the violet wire to a wire that shows (+)12V when any door is opened, and ground when the door is closed. This wire will report Zone 3.

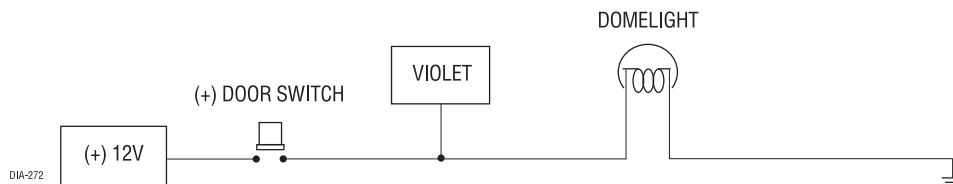

H1/8 BLACK (-) chassis ground connection

Remove any paint and connect this wire to bare metal, preferably with a factory bolt rather than your own screw. (Screws tend to either strip or loosen with time.) We recommend grounding all your components, including the siren, to the same point in the vehicle. See the following diagram.

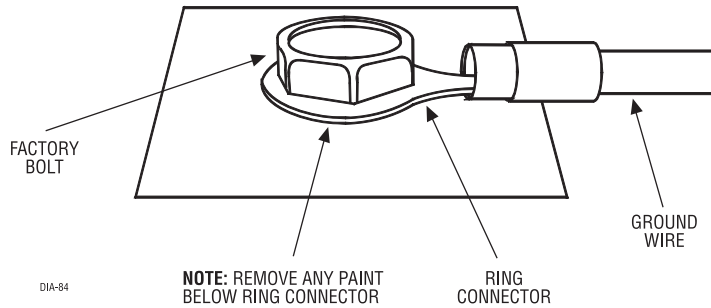

H1/9 YELLOW (+) ignition input, zone 5

Connect this wire to an ignition source. This input must show (+)12V with the key in run position and during cranking. Make sure that this wire cannot be shorted to the chassis at any point. This wire will report Zone 5.

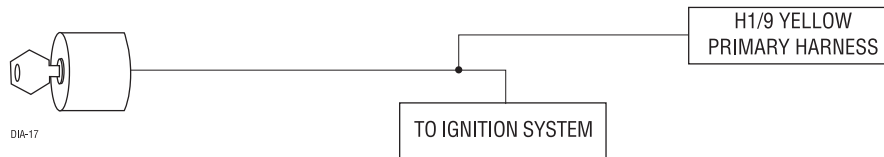

H1/10 BROWN (+) siren output

Connect this to the red wire of the siren. Connect the black wire of the siren to (-) chassis ground, preferably at the same point you connect the control module's black ground wire.

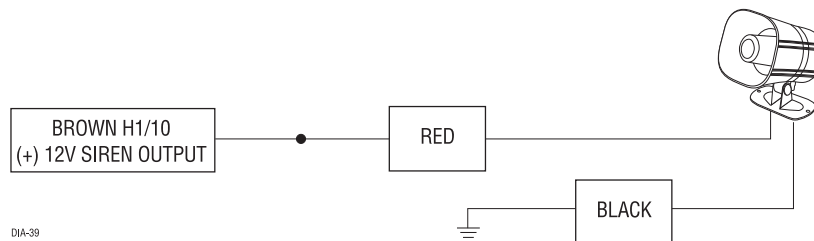

H1/11 RED (+) 12V constant power input

Before connecting this wire, remove the supplied fuse. Connect to the positive battery terminal or the constant 12V supply to the ignition switch.

NOTE: Always use a fuse within 12 inches of the point you obtain (+)12V power. Do not use the 15A fuse in the harness for this purpose. This fuse protects the module itself.

H1/12 RED/WHITE channel 2, (-) 200mA output

When the system receives the code controlling Channel 2, for longer than 1.5 seconds, the red/white wire will supply an output as long as the transmission continues. This is often used to operate a trunk/hatch release or other relay-driven function.

IMPORTANT! Never use this wire to drive anything but a relay or a low-current input! The transistorized output can only supply 200 mA of current. Connecting directly to a solenoid, motor, or other high-current device will cause it to fail.

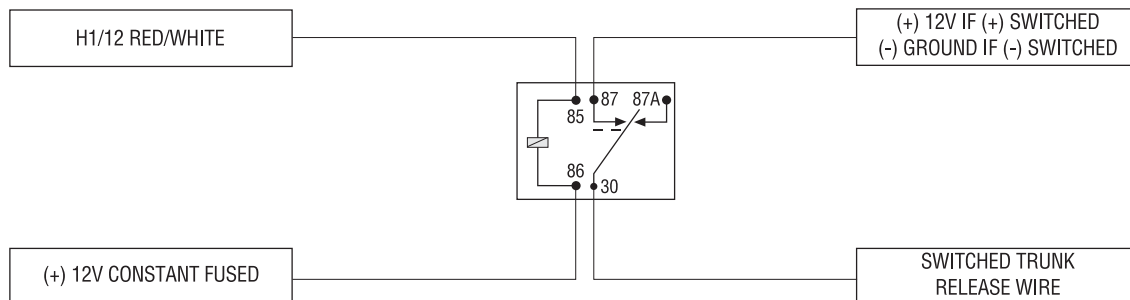

door lock harness (H2) wire connection guide

H2/1	GREEN	(-) LOCK, (+) UNLOCK OUTPUT
H2/2	OPEN	UNLESS USING 451M
H2/3	BLUE	(+) LOCK, (-) UNLOCK OUTPUT

This security system can control two common power door lock types without any additional parts! With certain vehicles, or if an actuator is to be installed, either a **451M** Door Lock Relay Satellite or two relays will be required.

type A: positive (+) 12V pulses from the switch to the factory relays

This security system can control Type A door locks directly, with no additional parts. The switch will have three wires on it, and one will test (+)12V constantly. The others will alternately pulse (+)12V when the switch is pressed to the lock or unlock position.

If you cannot get to the switch, and you find a set of wires that pulse (+)12V alternately on lock and unlock, you must take care to ensure that it is not a Type C direct-wire system.

IMPORTANT! If you mistake a Type C direct-wired system for a Type A positive-pulse system, the module will be damaged!

Here is a test: Cut the wire which pulses (+)12V on lock, and then operate the switch to unlock.

- If all doors unlock, the vehicle uses a Type A system.
- If you lose all door lock operation in both directions, you are operating the master switch in a Type C system.
- If one or more, but not all, motors stop operating, you have cut a wire leading directly to one or more motors. Reconnect the wire and look for another wire.

Many domestically-made GM vehicles use Type A locks. However, many more GM vehicles are Type C than in previous years. The full-size pickups (1989-later), many of the S10 Blazers, the Corvette, '95 Cavalier/Sunfire 1993 and newer, Camaro/Firebird all use Type C door locks, and cannot be controlled without a 451M! Almost all domestically-built Fords are Type C. Ford builds almost no Type A systems. Chrysler builds both Type A and Type C, so test carefully.

IMPORTANT! Remember that the functions of these wires reverse between Type A and Type B!

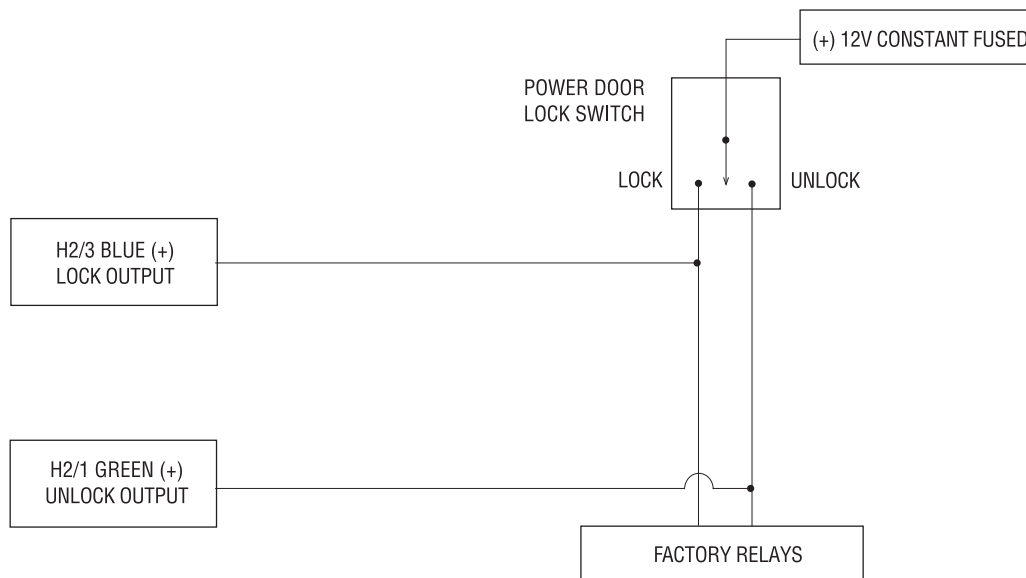

type B: negative (-) pulses from the switch to the factory relays

This system is common in many Toyota, Nissan, Honda, and Saturn models, as well as Fords with remote-controlled door lock/unlock (some other Fords also use Type B).

The switch will have three wires on it, and one wire will test ground all the time. One wire will pulse (-) when the switch locks the doors, and the other wire will pulse (-) when the switch unlocks the doors. This type of system is difficult to mistake for any other type.

IMPORTANT! Remember that the functions of these wires reverse between Type A and Type B!

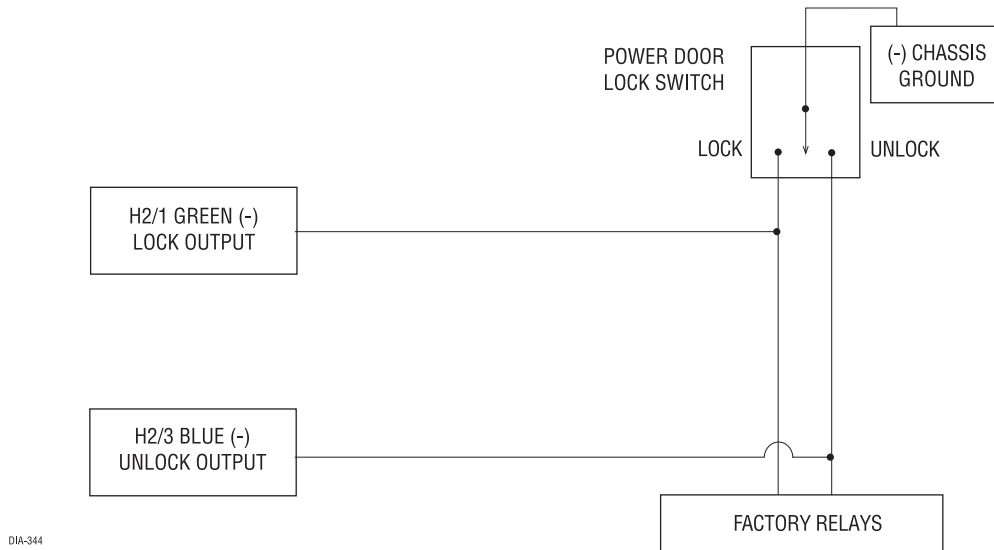

type C: reversing polarity

Interfacing with a reversing polarity system requires either two relays or one **451M** (not included).

It is critical to identify the proper wires and locate the master switch to interface properly. Locate wires that show voltage on lock and unlock. Cut one of the suspect wires and check operation of the locks from both switches. If one switch loses operation in both directions and the other switch operates in one direction only, you have located one of the target wires. The switch that lost all operation is the master switch. If one switch works both directions and the other switch works only one direction, you have a Type A system. If both switches still operate, but one or more doors have stopped responding entirely, you have cut a motor lead. Reconnect it and continue to test for another wire. Once both wires have been located and the master switch identified, cut both wires and interface as shown below.

IMPORTANT! If these are not connected properly, you will send (+) 12 volts directly to (-) ground, possibly damaging the alarm or the factory switch.

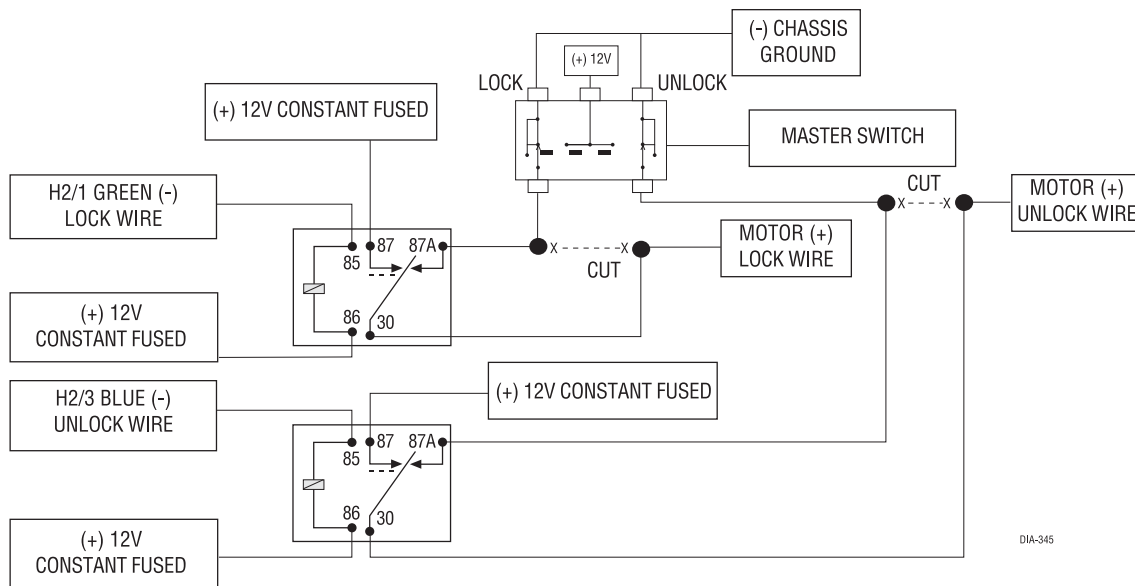

type D: after-market actuators

In order for this system to control one or more after-market actuators, a **451M** or two relays (optional) are needed.

Vehicles without factory power door locks require the installation of one actuator per door. This requires mounting the door lock actuator inside the door. Other vehicles may only require one actuator installed in the driver's door if all door locks are operated when the driver's lock is used. The fuse used on 12-volt inputs should be 7.5A per motor installed in the vehicle.

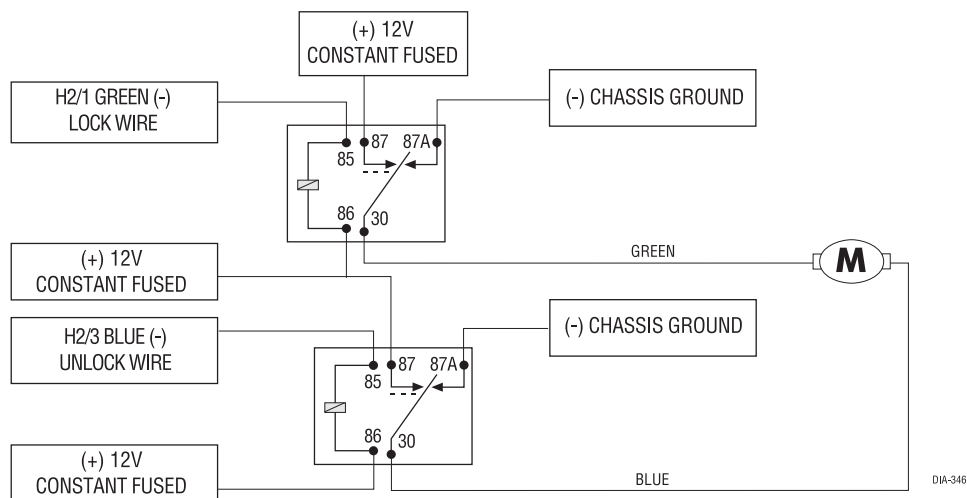

type E: mercedes-benz and audi (Certain years only)

Door locks are controlled by an electrically activated vacuum pump. Some Mercedes and Audi models use a Type D system. Test by locking doors from the passenger key cylinder. If all the doors lock, the vehicle's door lock system can be controlled with just two relays (optional). The control wire can be found in either kick panel and will show (+)12V when doors are unlocked and (-) ground when doors are locked.

To interface, see diagram below. The system must be programmed for 3.5 second door lock pulses. (See *Operating Settings Remote Control Code Learning* section of this guide.)

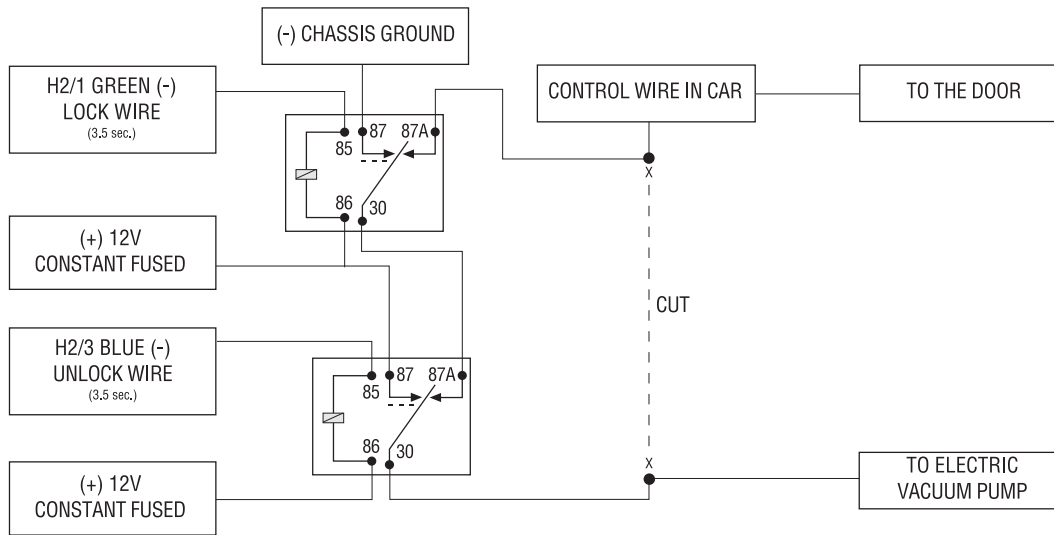

DIA-347

type F: one-wire system

This system usually requires a negative pulse to unlock, and cutting the wire to lock the door. In some vehicles, these are reversed. It is found in some Nissan Sentras, some Nissan 240SX, and Nissan some 300ZX. It is also found in some Mazda MPV's and some Mitsubishi's.

One relay (optional) is used to interface to this type of system as follows:

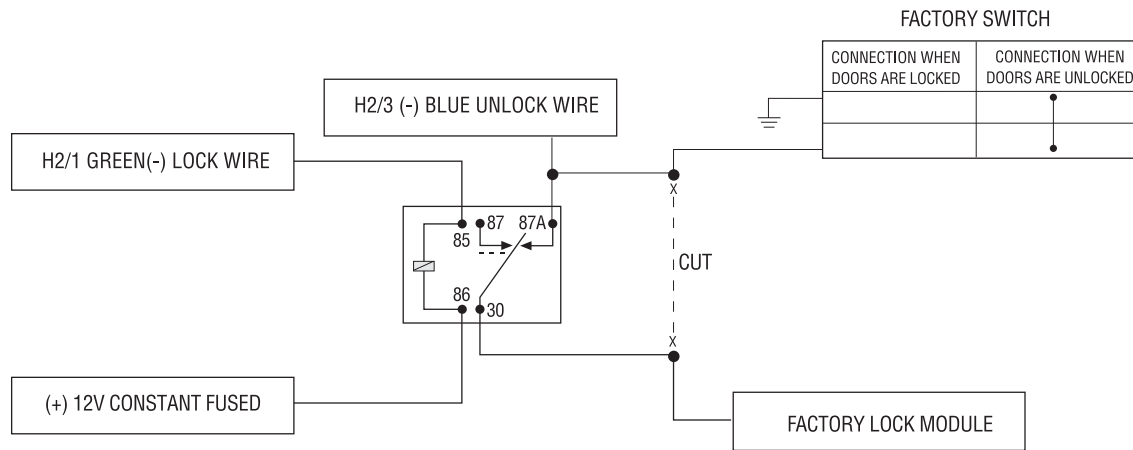

DIA-348

type G: positive (+) multiplex

This system is most commonly found in Ford, Mazda, Chrysler and GM vehicles. The door lock switch or door key cylinder may contain either one or two resistors. When interfacing with this type of door lock system, two relays or a **451M** must be used.

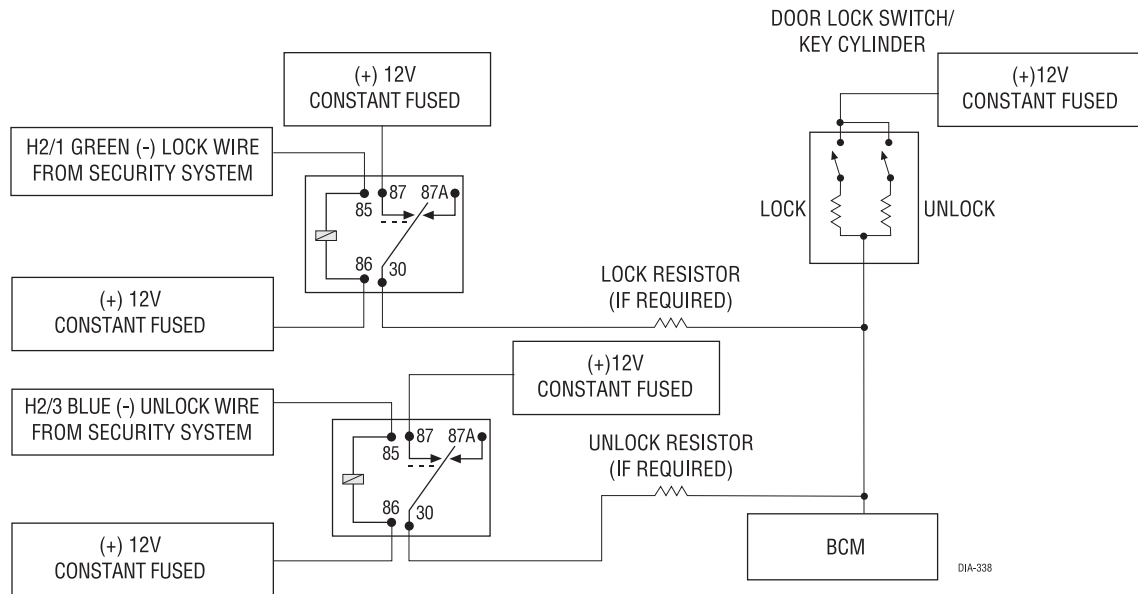

single-resistor type

If one resistor is used in the door lock switch/key cylinder, the wire will pulse (+)12V in one direction and less than (+)12V when operated in the opposite direction.

two-resistor type

If two resistors are used in the factory door lock switch/key cylinder, the switch/key cylinder will read less than (+)12V in both directions.

determining the proper resistor values

To determine the resistor values, the door lock switch/key cylinder must be isolated from the factory door lock system. For all testing, use a calibrated digital multimeter that is set to ohms.

1. Cut the output wire from the door lock switch/key cylinder in half.
2. Test with the meter from the switch side of the cut door lock switch/key cylinder wire to a reliable constant (+)12V source. Some good constant (+)12V references are the power input source to the door lock switch/key cylinder, the ignition switch power wire, or the (+) terminal of the battery.
3. Operate the door lock switch/key cylinder in both directions to determine the resistor values. If the multimeter displays zero resistance in one direction, no resistor is needed for that direction.
4. Once the resistor value(s) is determined, refer to the wiring diagram for proper wiring.

type H: negative (-) multiplex

The system is most commonly found in Ford, Mazda, Chrysler and GM vehicles. The door lock switch or door key cylinder may contain either one or two resistors. When interfacing with this type of door lock system, two relays or a **451M** must be used.

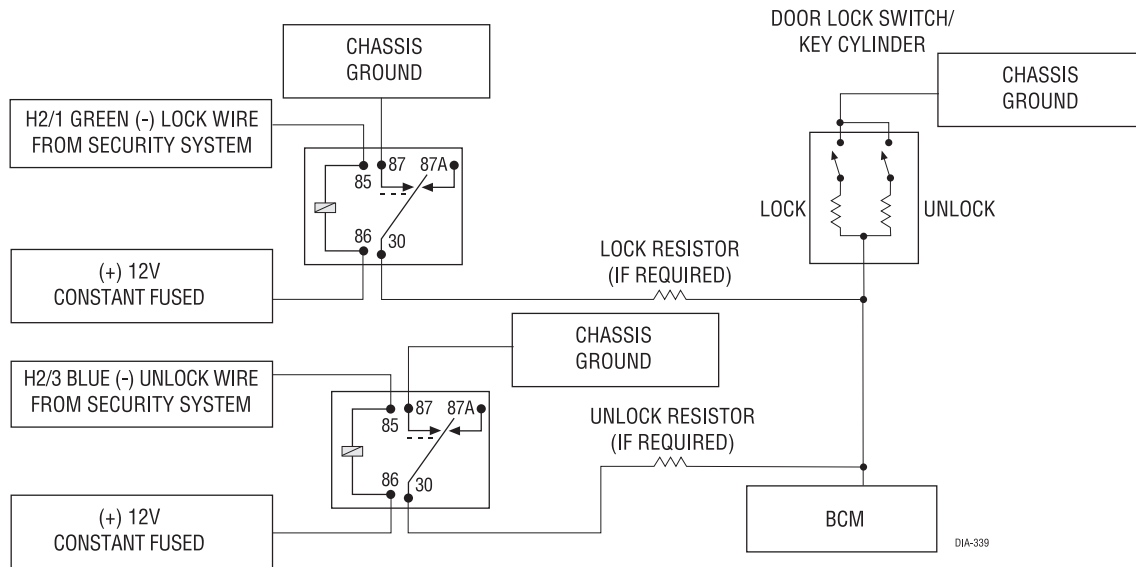

single-resistor type

If one resistor is used in the door lock switch/key cylinder, the wire will pulse ground in one direction and resistance to ground when operated in the opposite direction.

two-resistor type

If two resistors are used in the factory door lock switch/key cylinder, the door lock switch/key cylinder will read resistance to ground in both directions.

determining the proper resistor values

To determine the resistor values, the door lock switch/key cylinder must be isolated from the factory door lock system. For all testing, use a calibrated digital multimeter that is set to ohms.

1. Cut the output wire from the door lock switch/key cylinder in half.
2. Test with the meter from the switch side of the cut door lock switch/key cylinder wire to a reliable ground source. Some good ground references are the ground input source to the door lock switch/key cylinder or the battery ground.
3. Operate the door lock switch/key cylinder in both directions to determine the resistor values. If the multimeter displays zero resistance in one direction, no resistor is needed for that direction.
4. Once the resistor value(s) is determined, refer to the wiring diagram for proper wiring.

starter interrupt harness (H3) wire connection guide

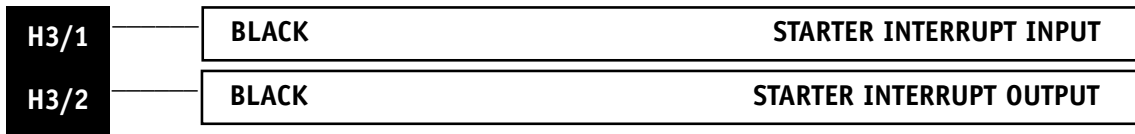

H3/1 and H3/2 BLACK starter interrupt wires

Use one of these wire as a starter interrupt input and the other as a starter interrupt output wire

NOTE: These two black wires are interchangeable.

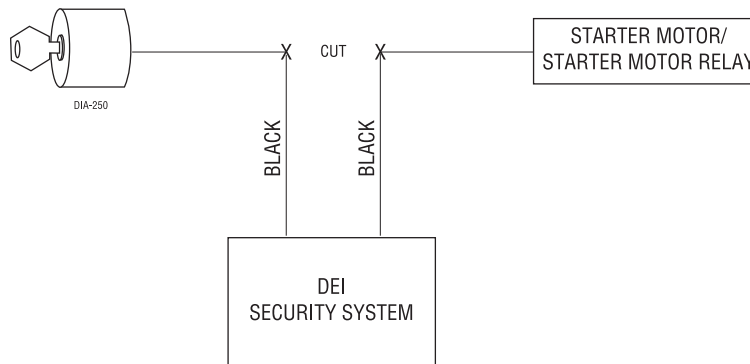

plug-in LED and valet/program switch

The LED and the Valet/Program switch both plug into the control module. The LED system status indicator plugs into the white two-pin port, while the Valet®/Program switch should be plugged into the blue two-pin port. The status LED and Valet®/Program switch each fit into 9/32-inch holes.

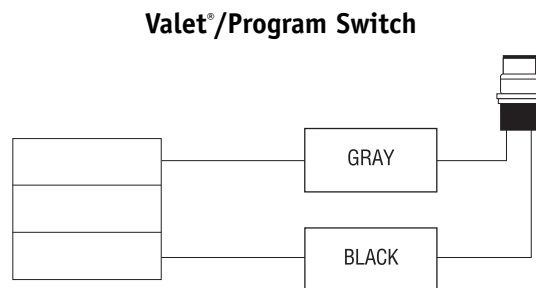
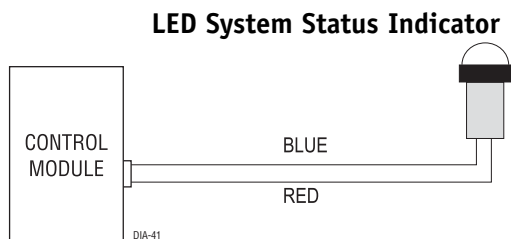

internal programming jumper

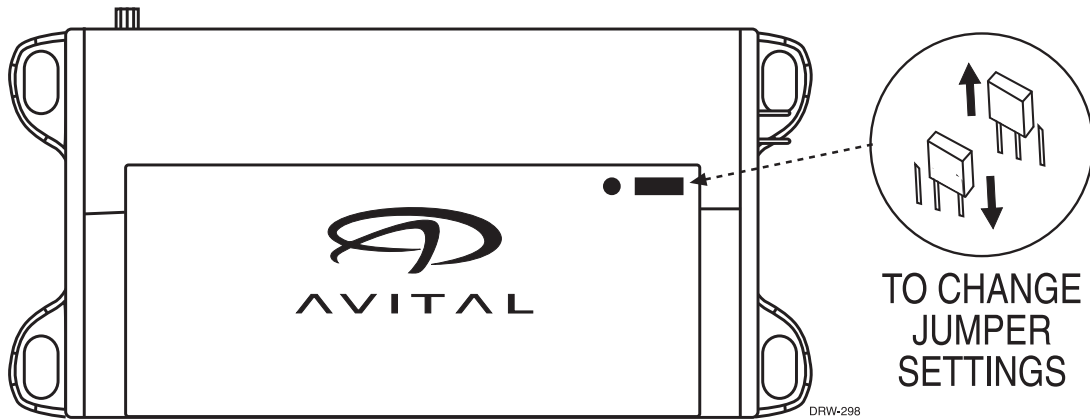

(-) Light flash output ● ● ● (+) Light flash output (default)

light flash jumper

This jumper is used to determine the light flash output. In the (+) position, the on-board relay is enabled and the unit will output (+)12V on the H1/2 WHITE wire. In the (-) position, the on-board relay is disabled. The H1/2 WHITE wire will supply a (-) 200 mA output suitable for driving factory parking light relays. To access the jumper, open the control module.

NOTE: For parking light circuits that draw 10 amps or more, the internal jumper must be switched to a (-) light flash output. **P/N 8617** or a standard automotive SPDT relay must be used on the H1/2 light flash output harness wire.

on-board dual stage zone 2 impact sensor

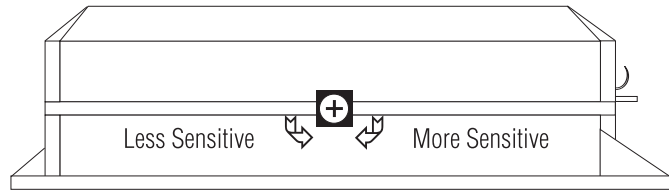

There is a dual-stage impact sensor inside the control unit. Adjustments are made via the rotary control as indicated above. Since the impact sensor does not work well when mounted firmly to metal, we recommend against screwing down the control module. We recommend mounting the control module to a large wiring loom.

NOTE: When adjusting the sensor, it must be mounted in the same location where it will be after the installation is completed. Adjusting the sensor and then relocating the module requires readjustment.

bypassing sensor inputs

There are times when you need to temporarily bypass all sensor inputs to the unit, such as when remote starting the vehicle. Anytime an auxiliary channel output is used, all inputs are bypassed for 5 seconds. During the 5 second bypass period, ground can be supplied to the H1/6 BLUE wire without triggering the unit. When the 5 second bypass period ends, if the unit detects ground on the H1/6 BLUE wire, all trigger inputs except the door trigger input will remain bypassed until 5 seconds after ground is removed from the BLUE wire. This can be done using the status output of a 551T remote start unit as shown below:

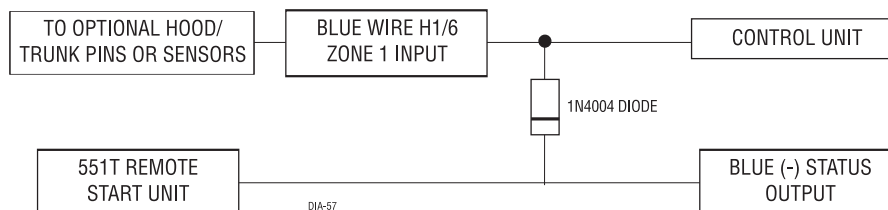

transmitter/receiver remote control code learning

The system comes with two transmitters that have been taught to the receiver. Use the following transmitter/receiver remote control code learning to add transmitters to the system or to change button assignments if desired.

The Valet®/Program button, plugged into the blue port, is used for programming. There is a basic sequence to remember whenever programming this unit: Door, Key, Choose, Transmit and Release.



1. **Open a door.** (The GREEN wire, H1/5, or the VIOLET, H1/7 must be connected.)



2. **Key.** Turn the ignition on. (The H1/9 YELLOW switched ignition input must be connected.)



3. **Select the receiver channel.** Press and release the Valet®/Program switch the number of times necessary to access the desired channel. Once you have selected a channel, press and **HOLD** the Valet®/Program switch once more. The siren will chirp and the LED will blink the number of times corresponding to the channel that has been accessed.

NOTE: If adding a remote, a button must be taught to Channel 1 prior to programming other channels.

CHANNEL NUMBER	PRESS AND RELEASE THE VALET/PROGRAM SWITCH	TO PROGRAM FUNCTION
1	One Time	Arm/Disarm/Panic
2	Two Times	Channel 2
3	Three Times	Channel 3
4	Four Times	Arm Only
5	Five Times	Disarm Only
6	Six Times	Panic Only
7	Seven Times	Auto-learn* for 3-button transmitters
8	Eight Times	Delete all transmitters**

***NOTE:** The Auto-learn function cannot be used to program an optional four-button transmitter; the channels must be taught to the transmitter individually. See Transmitter Configuration section of this guide for a description of Auto-learn transmitter programming.

****NOTE:** If any button from a known transmitter is programmed to Channel 8, all transmitters will be erased from memory and will revert to the default feature settings. (See Features Menu section of this guide.) This is useful in cases where one of the customer's transmitters is lost or stolen. Channel 8 will erase any lost or stolen transmitters from the system's memory and can also be used to start from scratch if the transmitter buttons were programmed incorrectly.



4. **Press the transmitter button.** While **HOLDING** the Valet®/Program switch, press the transmitter button that you wish to assign to that channel. The unit will chirp indicating successful programming. You cannot teach a transmitter button to the system more than once.

NOTE: For Channel 7, press Button I (see Transmitter Configuration section of this guide) to program the Auto-learn Standard Configuration on a three-button transmitter.



5. **Release.** Once the code is learned, the Valet®/Program button can be released.

You can advance from one channel to another by releasing the Valet® /Program button and tapping it to advance channels and then **HOLDING** it. For example, if you want to program Channel Three after programming Channel One, release the Valet®/Program button. Press it twice and release it to advance to Channel Three. Then press it once more and **HOLD** it. The siren will chirp three times to confirm it is ready to receive the code from the transmitter.

Code Learning will be exited if:

- Ignition is turned off.
- Door is closed.
- Valet®/Program button is pressed too many times.
- More than 15 seconds elapses between steps.

One long chirp indicates that Code Learning has been exited.

transmitter configuration

The transmitters can be programmed with the Standard Configuration by using the Channel 7 Auto-learn* function in the Transmitter/Receiver *Remote Control Code Learning*. When programmed for Standard Configuration, the 3-button transmitter buttons are assigned to the following functions:



Button I.....operates.....Arm/Disarm/Panic



Button IIoperates.....Channel Two



Button III.....operates.....Channel Three

***NOTE:** The Auto-learn function cannot be used to program an optional four-button transmitter. For a four-button transmitter, the different channels must be taught to the transmitter individually.

operating settings remote control code learning

Many of the operating settings of this unit are programmable. They can be changed whenever necessary through Operating Settings Remote Control Code Learning. The Valet®/Program push-button switch, plugged into the blue port, is used together with a programmed transmitter to change the settings.

The operating settings dictate how the unit operates. It is possible to access and change any of the feature settings using the Valet®/Program switch.

To enter Operating Settings Code Learning:

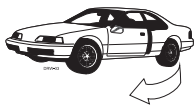

1. **Open a door.** (The GREEN wire, H1/5, or the VIOLET, H1/7 must be connected.)



2. **Ignition.** Turn the ignition on, then back off. (The H1/9 YELLOW switched ignition input must be connected.)

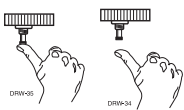

2. **Choose.** Within 10 seconds, press and release the Valet®/Program switch the number of times corresponding to the feature number you want to program (see the *Features Menu* section of this guide). The LED ON settings listed in the *Features Menu* table are the factory default settings.

Once the Valet/Program switch has been pressed and released the number of times corresponding to the feature you wish to program, press it once more and **HOLD** it. After a second, the LED will flash to indicate which feature you have accessed. For example, groups of five flashes would indicate access to Feature 5. The siren will also chirp five times.



4. **Transmit.** While **HOLDING** the Valet®/Program switch, you can select the desired feature settings using the remote transmitter. As shipped, the unit is configured to the default LED ON settings. Pressing Button I while **HOLDING** down the Valet/Program switch will program the feature to the LED ON settings. The siren will chirp once to indicate the one-chirp setting has been selected. Pressing Button II while **HOLDING** down the Valet/Program switch will change the setting to the LED OFF setting. The siren will chirp twice indicating that the LED OFF setting has been selected.



5. **Release.** Release the Valet®/Program switch.

To access another feature:

You can advance from feature to feature by pressing and releasing the Valet®/Program switch the number of times necessary to get from the feature you just programmed to the feature you wish to access. For example, if you just programmed Feature 1 and you want to program Feature 2:

1. Release the Valet®/Program switch.
2. Press and release the Valet/Program switch once to advance from Feature 1 to Feature 2.
3. Press the Valet®/Program switch once more and **HOLD** it.
4. The siren will chirp two times to confirm that you have accessed Feature 2.

To exit the Code Learning, do one of the following:

- Close the open door.
- Turn the ignition on.
- No activity for longer than 15 seconds.
- Press the Valet®/Program switch too many times.

features menu

FEATURE NUMBER	DEFAULT LED ON SETTINGS (PRESS TRANSMITTER BUTTON I)	LED OFF SETTINGS (PRESS TRANSMITTER BUTTON II)
1	Active Arming	Passive Arming
2	Confirmation Chirps ON	Confirmation Chirps OFF
3	Ignition-Controlled Door Lock/Unlock ON	Ignition-controlled Door Lock/Unlock OFF
4	Active Locking	Passive Locking
5	0.8-second Door Lock Pulse Duration	3.5-second Door Lock Pulse Duration
6	Double Pulse Unlock OFF	Double Pulse Unlock ON
7	Code Hopping Technology ON	Code HoppingTechnology OFF

NOTE: Factory defaults are indicated in *bold* type.

feature descriptions

- 1 ACTIVE/PASSIVE ARMING:** When active arming is selected, the system will only arm when the transmitter is used. When set to passive, the system will arm automatically 30 seconds after the last door is closed. Passive arming is indicated by the rapid flashing of the LED when the last protected entry point is closed.
- 2 CONFIRMATION CHIRPS ON/OFF:** This feature controls the chirps that confirm the arming and disarming of the system.
- 3 IGNITION-CONTROLLED DOOR LOCK/UNLOCK ON/OFF:** When turned on, the doors will lock three seconds after the ignition is turned on and unlock when the ignition is turned off. If the ignition key is turned on while the vehicle door(s) are open, the door(s) will not lock.
- 4 ACTIVE/PASSIVE LOCKING:** If passive arming is selected in Feature 1, then the system can be programmed to either lock the doors when passive arming occurs, or only lock the doors when the system is armed with the transmitter. Active locking means the system will not lock the doors when it passively arms. Passive locking means that the system will lock the doors when it passively arms.
- 5 DOOR LOCK PULSE DURATION:** Some European vehicles, such as Mercedes-Benz and Audi, require longer lock and unlock pulses to operate the vacuum pump. Programming the system to provide 3.5 second pulses will accommodate door lock interface in these vehicles. The default setting is 0.8 second door lock pulses. See *Mercedes-Benz and Audi - 1985 and Newer (Type E Door Locks section)* diagram.
- 6 DOUBLE PULSE UNLOCK OFF/ON:** Some vehicles require two pulses on a single wire to unlock the doors. When the double pulse unlock feature is turned on, the H2/3 BLUE wire will supply two negative pulses instead of a single pulse. This makes it possible to directly interface with double pulse vehicles without any extra parts.
- 7 CODE HOPPING TECHNOLOGY ON/OFF:** This system features Code Hopping Technology as an option. Code Hopping Technology is a feature that uses a mathematical formula to change the system's code each time the transmitter and receiver communicate. This makes the group of bits or "word" from the transmitter very long. The longer the word is, the easier it is to block its transmission to the unit. Disabling the Code Hopping Technology feature lets the receiver ignore the Code Hopping Technology part of the transmitted word. As a result, the unit may have better range with Code Hopping Technology off.

nuisance prevention circuitry™

NPC™ requires that you change the way you test the system, as NPC™ will bypass an input zone for 60 minutes. If the system “sees” the same zone trigger three times AND the triggers are spaced less than an hour apart, the system will bypass that input zone for 60 minutes. If that zone does not attempt to trigger the system during the 60-minute bypass period, the zone’s monitoring will begin again at the end of the hour. If it does attempt to trigger while bypassed, the 60-minute bypass starts over again.

Disarming and rearming the system does not reset NPC™. The only way to reset NPC™ is for the 60 minutes to pass, without a trigger, or for the ignition to be turned on. This allows the system to be repeatedly triggered, disarmed and rearmed, and still allow NPC™ to bypass a faulty zone.

When disarming the system, 5 chirps indicate NPC is activated. The LED will report the zone that has been bypassed. (See *Table of Zones* section of this guide.)

table of zones

When using the Diagnostic functions, use the Table of Zones to see which input has triggered the system. It is also helpful in deciding which input to use when connecting optional sensors and switches.

ZONE NO.	TRIGGER TYPE	INPUT DESCRIPTION
1	Multiplexed	H1/6 BLUE wire. Connects to optional hood/trunk pins or an optional sensor. Inputs longer than 0.8 seconds will instantly trigger the full alarm sequence and report Zone 1.
2	On-board impact sensor	Second-stage of on-board impact sensor (heavy impacts from impact sensor).
3	Two-stage, progresses from warning to full alarm	Door switch circuit. H1/5 GREEN or H1/7 VIOLET.
5	Two-stage, progresses from warning to full alarm	Ignition. H1/9 YELLOW.

NOTE: *The Warn-away response does not report on the LED.*

troubleshooting

■ **Door input does not immediately trigger full alarm. Instead, first I hear chirps for 3 seconds:**

That's how the progressive two-stage door input works! This is a feature of this system. This is an instant trigger, remember, since even if the door is instantly re-closed, the progression from chirps to constant siren will continue.

■ **Closing the door triggers the system, but opening the door does not:**

Have you correctly identified the type of door switch system? This often happens when the wrong door input has been used. (See *H1/5 GREEN Door Trigger Input, Primary Harness Wire Connection Guide* section of this guide.)

■ **System will not passively arm until it is remotely armed and then disarmed:**

Are the door inputs connected? Is the H1/6 blue wire connected to the door trigger wire in the vehicle? Either the H1/5 green or the H1/7 violet should be used instead. (See *Primary Harness Wire Connection Guide* section of this guide.)

■ **Door input does not respond with the progressive trigger, but with immediate full alarm:**

Does the LED indicate that the trigger was caused by the impact sensor? (See *Table of Zones* section of this guide.) The impact sensor, if set to extreme sensitivity, may be detecting the door unlatching before the door switch sends its signal. Reducing the sensitivity can solve this problem.

■ **The Valet®/Program switch does not work:**

Is it plugged into the correct socket? (See *Plug-In LED and Valet/Program Switch* section of this guide.)

■ **The LED system status indicator does not work:**

You've probably guessed already, but here goes: is it plugged in? Is the LED plugged into the correct socket? (See *Plug-In LED and Valet/Program Switch* section of this guide.)

■ **Starter interrupt does not work:**

Is the correct wire being interrupted? If the vehicle starts when the starter interrupt is completely disconnected, the wrong wire has been cut.

Is the yellow H1/9 ignition wire connected to true ignition? This wire must be powered in the run and start positions in order to work properly.